

36V 2A Micro-step silent motor driver

1. Overview

GC6610 is an ultra silent two-phase stepping motor driving chip with built-in step driving mode with maximum 256 micro step, ultra silent and low vibration. The chip can work in a wide voltage range of 4 ~ 36V, with rms current to 2A or peak current to 4A.

With integrated automatic gain control loop (AGC) circuit, motor torque automatic adjusted and compensated for variable load or speed to ensure consistent torque.

Automatic power saving function is integrated when the motor is hold on for fit time.

Comprehensive output protection, including over temperature protection, under voltage protection, etc.

Feature description

- Two phase stepping motor, maximum rms current up to 2A or peak current to 4A
- Step / dir interface, max 256-micro step control model, resolution is selected by MS1,MS2
- Power supply range: 4V ~ 36V
- With ultra-low motor noise, AGC can automatically compensate torque in a wide speed range
- Automatic power saving function when the motor is held
- Over temperature protection, under voltage protection
- Error and state indication pin FLAG
- TSSOP28pp package
- UART one wire interface

2. Application

- White goods
- Office machines
- 3D printer
- medical apparatus and instruments
- PTZ control



Packaging Introduction

Per Tray	Per Box	Per Case
3K	6K	48K

3.Pin diagram

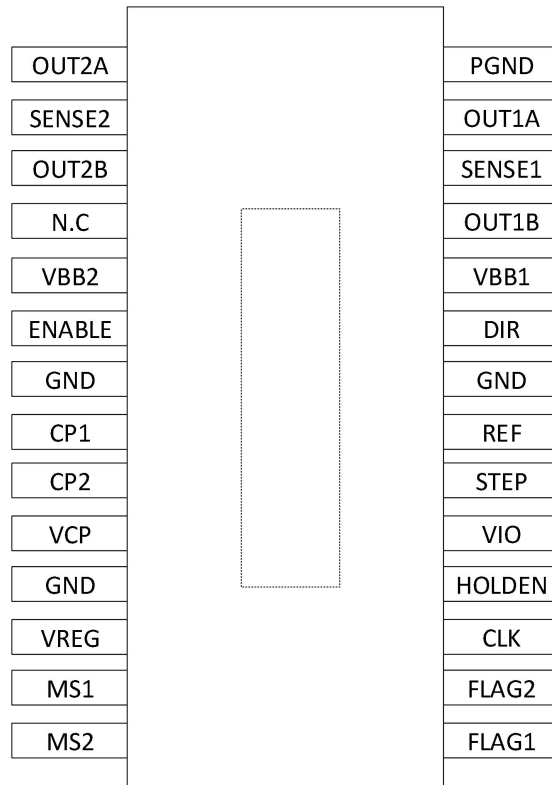

Num	Pin	Type	Function
1	OUT2A	O	Motor coil A output 2
2	SENSE2	I/O	Sense resistor connection for coil B. Place sense resistor to GND nearby
3	OUT2B	O	Motor coil B output 2
4	NC	I/O	Unused pin, leave open or connect to GND
6	ENABLE	I	Output enable.The power stage becomes switched off (all motor outputs floating) when input 'high'
7, 11, 22	GND	Ground	GND
8	CP1	I/O	Charge pump capacitor output
9	CP2	I/O	Charge pump capacitor input. Tie to CP1 using 22nF 50V capacitor
10	VCP	O	Charge pump voltage. Tie to VS using 100nF capacitor.
12	VREG	O	Output of internal 5V regulator. Attach 2.2μF to 4.7μF ceramic capacitor to GND nearby for best performance. Provide the shortest possible loop to the GND pad.
13	MS1	I	Microstep resolution configuration (internal pull down resistors)MS2, MS1: 00: 1/8, 01: 1/2, 10: 1/4 11: 1/16
14	MS2	I	
15	FLAG1	O	Diagnostic output. Hi level when driving error happen. Reset by ENN=high.

16	FLAG2	O	Configurable FLAG2 output. Provides FLAG2 pulse.
17	CLK	I/O	12MHz CLK input. Tie to GND when using internal clock
18	HOLDEN	I/O	Auto power save when hold on. (low = automatic standstill current reduction). Optional UART Input/Output. Power down function can be disabled in UART mode.
19	VIO	Power	3.3V to 5V IO supply voltage for all digital pins
20	STEP	I	STEP input
21	REF	I	Analog reference voltage for current scaling
23	DIR	I	DIR input (internal pull down resistor)
24	VBB1	Power	Motor supply voltage. Provide filtering capacity nearby with shortest possible loop to GND pad
25	OUT1B	O	Motor coil B output 1
26	SENSE1	I/O	Sense resistor connection for coil A. Place sense resistor to GND nearby
27	OUT1A	O	Motor coil A output 1
28	PGND	Ground	GND

4.Application Block Diagram

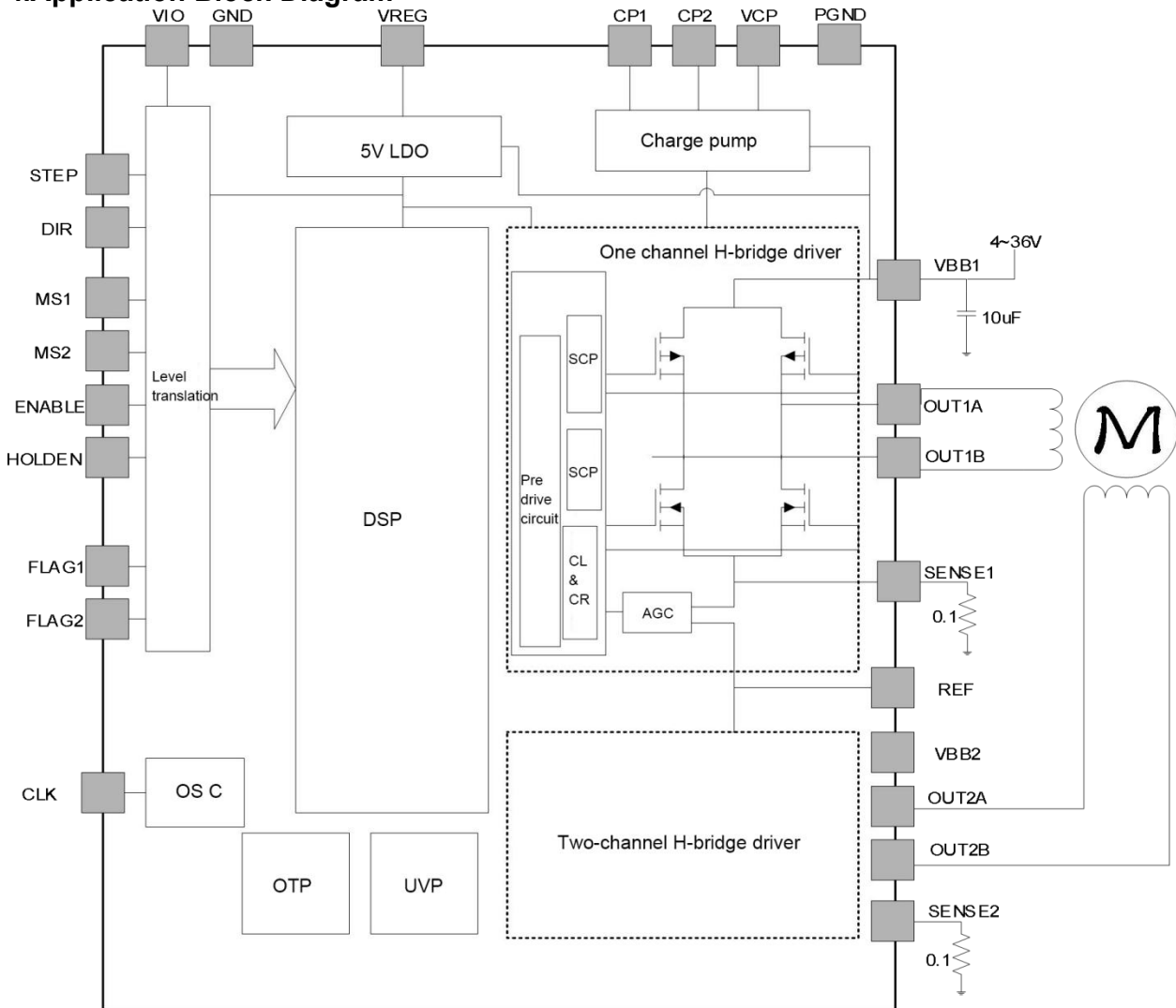

5. Performance Parameter

5.1 Absolute Maximum Ratings

Parameter		Min	Max	Unit
VBB	Supply voltage operating with inductive load	-0.5	40	V
VIO	I/O supply voltage	-0.5	6	V
Logic input / output (STEP, DIR, CLK, ENABLE, MS1, MS2, HOLDEN, FLAG1, FLAG2)		-0.5	VIO	V
SENSE	Current sense pin	-0.5	0.5	V
REF	Current scale setting pin	-0.5	6	V
VREG	LDO Maximum output current	50		mA
Ipeak	Maximum sine wave peak current	4		A
Topr	Operating temperature	-40	125	°C
Tstg	Storage temperature	-60	150	°C
ESD	ESD-Protection for interface pins (Human body model, HBM)	-4000	+4000	V

5.2 Operational Range

Parameter		Min	Max	Unit
VBB	Power supply voltage	4.7	36	V
VIO	Logic supply voltage	3.0	5.5	V
Logic input / output		-0.5	7	V
Irms	RMS motor coil current per coil	2		A

5.3 Electrical parameters

No other specify, general test conditions: VBB=24V, T=25°C

Symbol	Parameter	Conditions	Min	Typ	Max	Unit
Power supply						
I _{VBB}	VBB Working current	VBB=24V, CLK frequency=12MHz	-	7.8	11	mA
V _{UVLO}	VBB Undervoltage protection	When VBB rise up	-	4.3	-	V
V _{HYS}	VBB Undervoltage protection hysteresis		-	0.24	-	V
Interface logic power supply VIO						
I _{VIO}	Interface logic power supply			300		uA

V _{uvio}	Interface power under voltage protect			2.5		V
Logic input (STEP,DIR,CLK, ENABLE,MS1,MS2, HOLDEN)						
V _{IL}	Input low level	xINx input	-	-	0.3*V _{IO}	V
V _{IH}	Input high level	xINx input	0.7*V _{IO}	-	-	V
V _{HYS}	Input hysteresis		-	0.12*V _{IO}	-	V
FLAG Output (FLAG1, FLAG2)						
V _{OL}	FLAG low	I _{out} = 2mA	-	-	0.5	V
V _{OH}	FLAG high	I _{out} = -2mA	V _{IO} -0.5	-	-	V
Output H bridge						
R _{ON}	R _{DSon} highside MOSFET	V _{BB} =24V, T=25°, I _{out} =0.5A	-	0.2	-	Ω
	R _{DSon} lowside MOSFET		-	0.2	-	Ω
I _{OFF}	Turn off leakage current	Output = 0	-	200	-	uA
T _{LH}	Rise conversion time	24V/24Ω Resistive load, low20% to high80%		60		ns
T _{HL}	Descent transition time	24V/24Ω Resistive load, high80%to low20%		60		ns
Overcurrent protection						
t _{DEAD}	Dead Time	Internal parameters	100	-	-	ns
I _{OCpup}	Short circuit protection point	Short circuit to GND when the highside MOSFET is opened	-	V _{BB} -2	-	V
I _{OCpdown}	Short circuit protection point	Short circuit to Power when the lowside MOSFET is opened	-	2	-	V
t _{DEG}	Overcurrent detection time	Effective duration of overcurrent detection	-	2	-	us
Over temperature protection						
T _{TSD}	Over temperature protection point	temperature rise	-	156	-	°C
T _{TSDth}	Over temperature protection hysteresis		-	26	-	°C
5V LDO Output VREG						
V _{vreg}	output voltage	When the load is 0mA		5.0		V
		When the load is 5mA		4.95		V
V _{uvLDO}	VREG Undervoltage protection			3.5		V
Charge pump						
V _{vcp}	VCP output voltage			V _{BB} +4.7		V

V _{vcpl0}	VCP Output undervoltage	VCP Undervoltage shutdown voltage point		V _{BB} +3.5		V
V _{vcpr}	VCP output frequency	VCP oscillation frequency, F _{CLK} =12MHz		750		KHz
CLK Clock						
F _{clk}	Input frequency range	External clock input	4	12	18	MHz
	Oscillation frequency range	No external input, use internal clock	11	12	13	MHz
Current setting pin REF (Dangling default 2.5V)						
V _{REF}	Voltage range	REF Control current, linear control area	0.5	-	2.5	V

6.Function

GC6610 is a two-phase stepping motor drive chip, with working voltage of 36V and current of 2A. With the ultra-low noise and low vibration characteristics, the chip is suitable for high precision performance control fields, such as 3D printing, medical devices, office equipment, security monitoring and other industries.

The chip adopts the standard step / dir interface, the rising edge of each step pulse, the motor runs an action, and MS1 and MS2 select the step angle of the motor in each action; Dir controls the running direction of the motor.

When the motor operates at different frequencies and loads, the torque will decay. The chip has built-in automatic gain control compensation circuit, which compensates when the torque decays, and can keep the torque constant in a wide speed range.

When the motor stops, the current power consumption of the stepping motor is relatively large. The chip has a built-in power-saving circuit. When the detection motor stops for more than a certain time, it enters the power-saving mode.

6.1 STEP/DIR Step mode

The chip adopts step / dir step control mode, and 256 micro step control is integrated inside. MS1 and MS2 control the step angle of each step pulse

MS2	MS1	Step subdivision
0	0	1/8
0	1	1/2
1	0	1/4
1	1	1/16

6.2 Current setting of motor

Set the current by adjusting the voltage of ref pin and the detection resistance of sense pin. Ref when the voltage is between 0.5 ~ 2.5V, the current of the motor can be set linearly. The basic relationship is as follows: $I_{rms} = 0.092 * V_{REF} / R_{SENSE}$

The precise control of REF can be output by PWM + RC filter (such as 20kHz PWM frequency, 22K resistor and 1uF capacitor). If higher precision is required, it can be driven by DAC output, and for low cost, it can be driven by resistance partial voltage (such as the sum of proportional resistors 10K).

REF default Voltage is 2.5V when suspended.

6.3 Automatic power saving when the motor is hold on

When the motor is stationary, especially when it stops at 1 / 2 step position, the current will be very large, and the motor generates lots of heat and uneconomical. General methods to reduce the current is to set of REF lower manually.

Automatic power saving function is built into GC6610. When the motor is stationary for more than a certain time (about 400ms), it enters the power saving mode. At this time, the current drops to 50% of the normal working current. When the step signal comes, the motor will leave the power saving mode.

Holden pin is the function enable pin. When Low is valid, whereas high is invalid. A pull-down resistance set the default value 'Low'.

6.4 Over temperature protection, under voltage protection

The chip integrates over temperature protection circuit. When the temperature exceeds 156 °C, the chip turns off the output; When the temperature recovers to 130 °C, the chip output driver will automatically restart.

VBB voltage detection: When the voltage is lower than 4.2V, the under-voltage protection is turned on and the output drive is turned off. D

VREG voltage detection: When the voltage is lower than 3.5V, the under-voltage protection is turned on and the output drive is turned off. Detect the voltage of VIO. When the voltage is lower than 2.5V, the under-voltage protection is turned on and the output drive is turned off.

6.5 FLAG Abnormal flag bit output

FLAG1 The signal is used to mark that the chip's working status. The normal value is low. When there are abnormal conditions such as over temperature, under-voltage, overcurrent and so on, FLAG1 will output a high-level pulse signal . When ENN pin is high, FLAG1 will be reset.

FLAG2 The signal is used to mark the position of the motor. A positive pulse is output every four step angles. The pulse is located at the starting position of the motor, that is, the positive zero crossing position of the sine wave current (coil A).

6.6 CLK Clock

CLK is the clock input pin, with an input range of 4 ~ 18Mhz, 12Mhz is recommended. If this pin is connected to GND, the system automatically uses the internal clock, which is about 12Mhz.

6.7 Charge pump

The chargepump circuit is used to generate a power supply to drive the upper bridge power mosfet . Generally, a 50V 0.022uf capacitor is connected between CP1 and CP2, and a 50V 0.1uF capacitor is connected between VBB and VCP

6.8 UART Interface

One wire interface allows unidirectional operation (for parameter setting only), or bi-directional operation for full control and diagnostics. It can be driven by any standard microcontroller UART or even by bit banging in software. Baud rates from 9600 Baud to 500k Baud or even higher (when using an external clock) may be used. No baud rate configuration is required, as the GC6610 automatically adapts to the masters' baud rate. A CRC checksum allows data transmission over longer distance. For fixed initialization sequences, store the data including CRC into the μ C, thus consuming only a few 100 bytes of code for a full initialization. CRC may be ignored during read access, if not desired. This makes CRC use an optional feature! The IC has a fixed address. Multiple drivers can be programmed in parallel by tying together all interface pins, in case no read access is required. An optional addressing can be provided by analog multiplexers, like 74HC4066.

For a more detailed description of serial port configuration, please refer to the user's manual

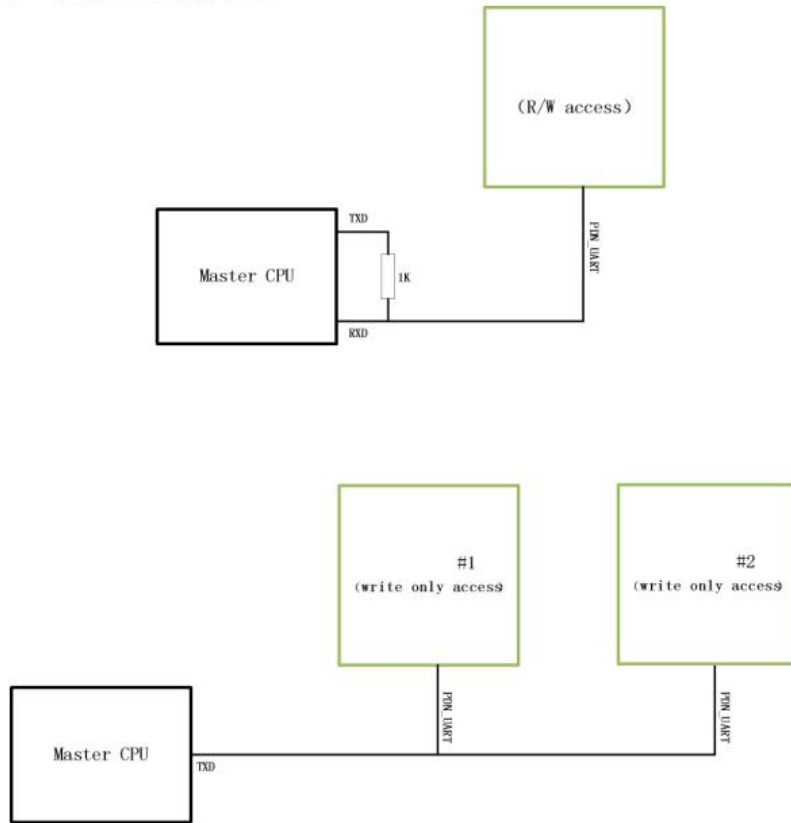
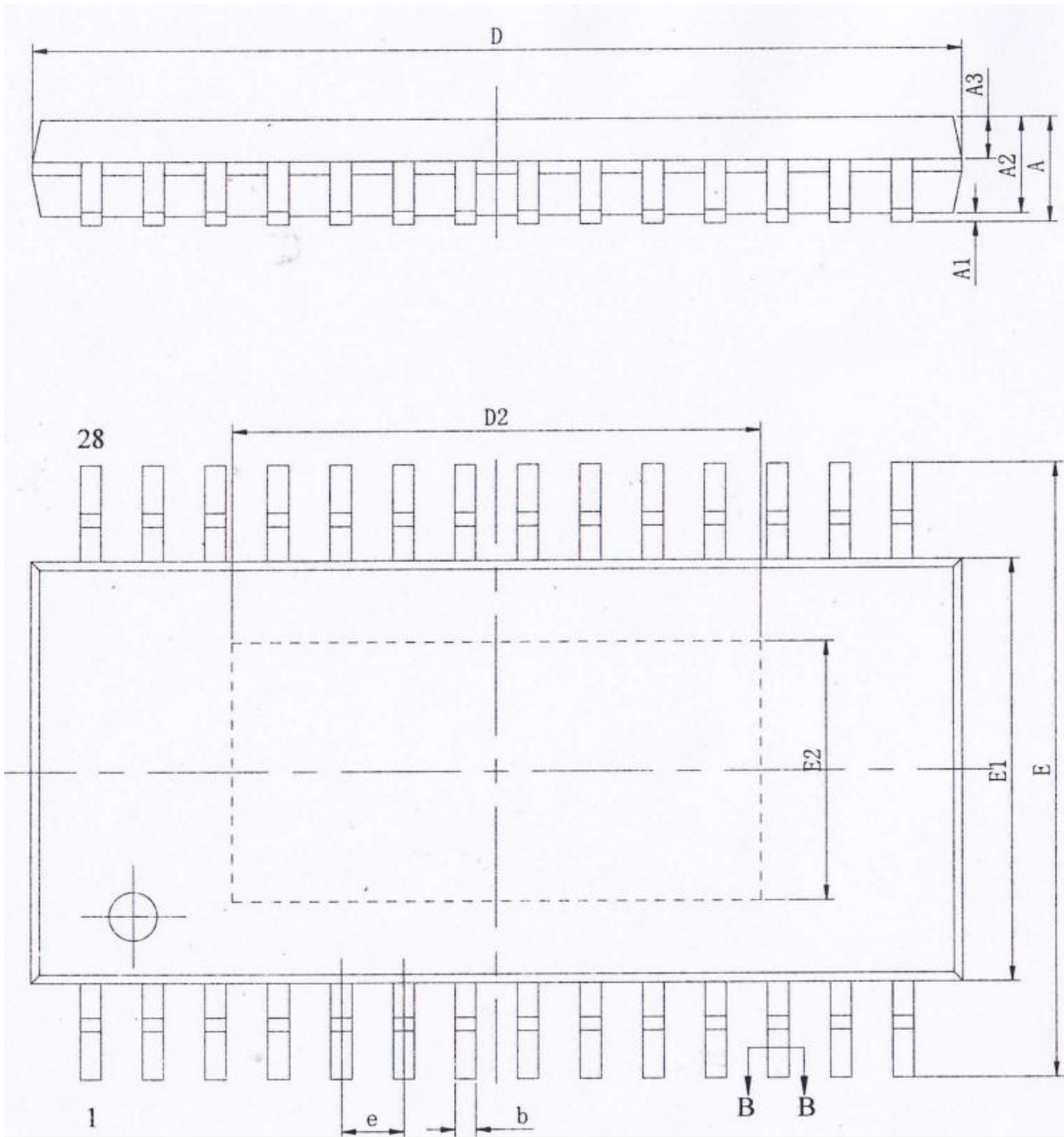
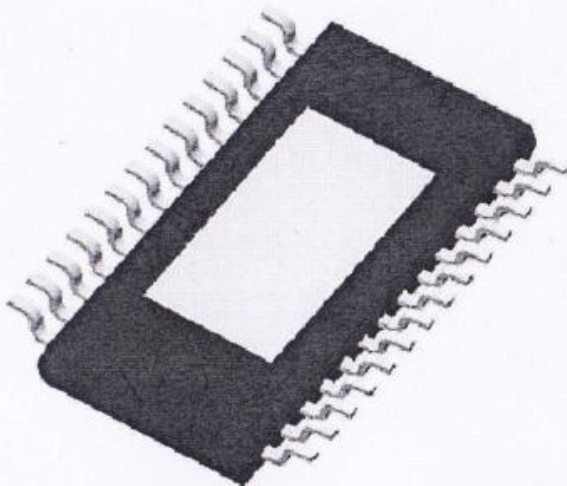
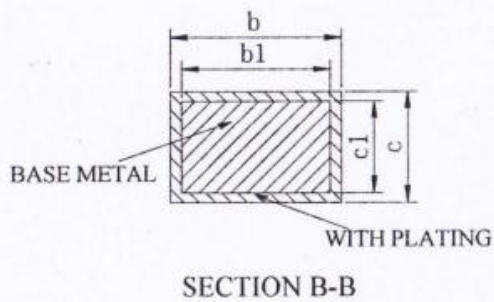
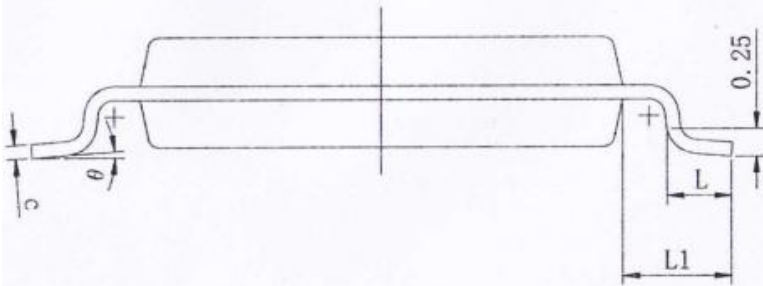

Figure 5.8 MCU control serial port

7. Packaging block
eTSSOP28





SYMBOL	MILLIMETER		
	MIN	NOM	MAX
A	—	—	1.20
A1	0.05	—	0.15
A2	0.80	—	1.00
A3	0.39	0.44	0.49
b	0.20	—	0.29
b1	0.19	0.22	0.25
c	0.13	—	0.18
c1	0.12	0.13	0.15
D	9.60	9.70	9.80
E	6.20	6.40	6.60
E1	4.30	4.40	4.50
e	0.65BSC		
L	0.45	0.60	0.75
L1	1.00BSC		
θ	0	—	8°



L/F载体尺寸 (mil)	D2	E2
150*110	3.66 REF	2.65 REF
232*118	5.50 REF	2.70 REF

8.Application block diagram