

## Lens Driver IC for camcorder and security-camera

### Chip description:

The GC6208 is a lens motor driver IC for camcorder and security-camera .

This device integrates a DC motor driver for Iris which controlled by PID system, and also has two channels STM motor drivers for zoom and focus control.

### Chip features:

- Built in DC motor driver for Iris controller
- Built in 2 STM driver for zoom and focus
- 256 u-step driving technology for STM , features supper low noise
- 2 systems of open-drain for driving LED
- Over temperature protection
- QFN44(06x06) Package

### Chip application:

- Camcorder
- Security-camera
- Consumer Products
- Robotics
- Medical Devices

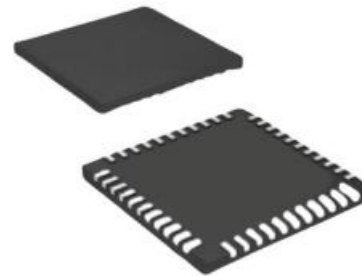

Product name	Package Type	Detail description
GC6208	LGA 6*6	6.0*6.0, e=0.4

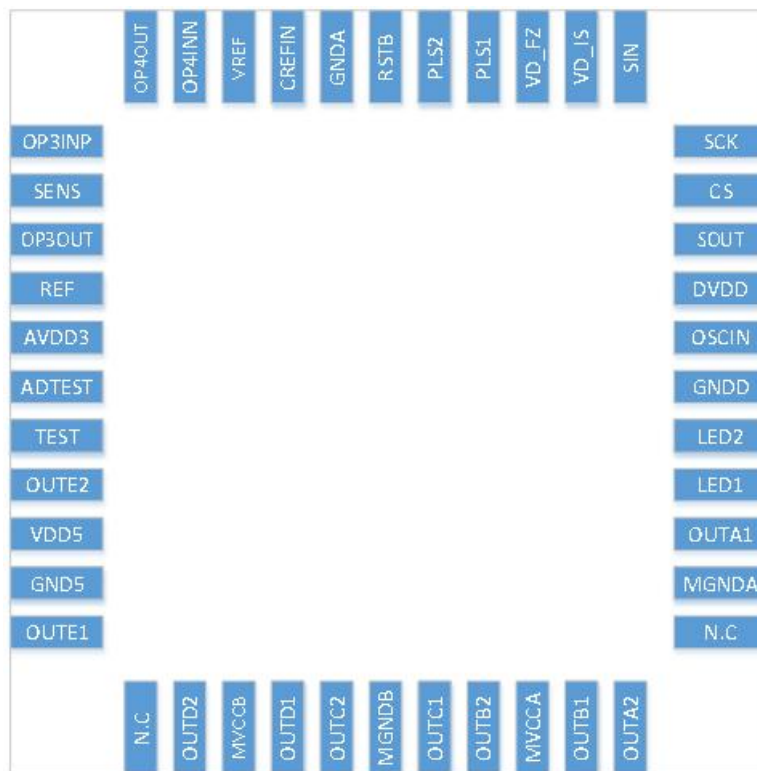
**Pin Map:**

**Pin Description:**

Pin No.	Pin Name	I/O	Pin Function
1	OP3INP	I	Hall signal amplifier non-inverting input
2	SENS	O	Hall current bias
3	OP3OUT	O	Hall signal amplifier output
4	REF	IO	Hall current reference setting by resistor connection
5	AVDD3	Power	3.3V Analog power
6	ADTEST	I	ADC test input
7	TEST	I	Test mode input
8	OUTE2	O	Motor output E2
9	VDD5	Power	Motor power supply
10	GND5	gnd	Motor E ground
11	OUTE1	O	Motor output E1
12	N.C	N.c	No connection inside
13	OUTD2	O	Motor output D2
14	MVCCB	Power	Motor B supply

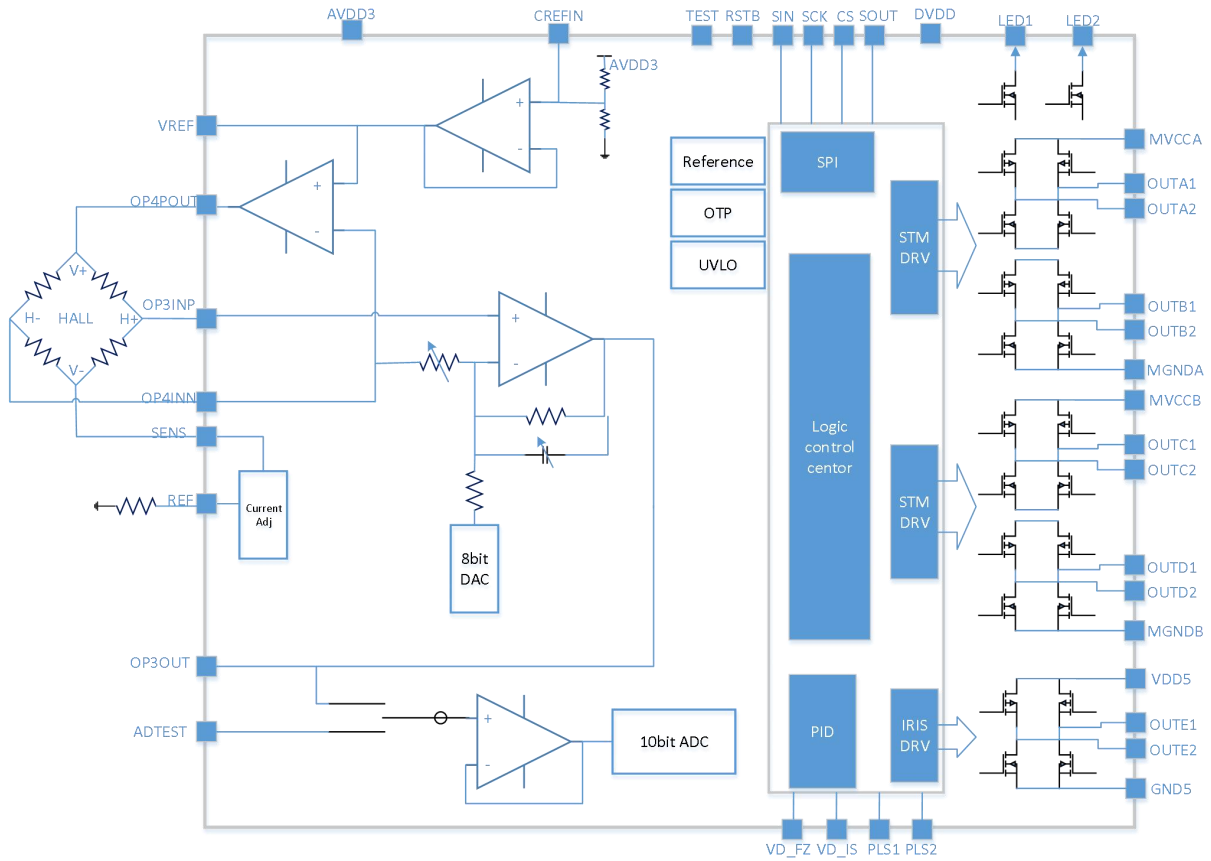
15	OUTD1	O	Motor output D1
16	OUTC2	O	Motor output C2
17	MGNDB	Gnd	Motor B ground
18	OUTC1	O	Motor output C1
19	OUTB2	O	Motor output B2
20	MVCCA	ground	Motor A ground
21	OUTB1	O	Motor output B1
22	OUTA2	O	Motor output A2
23	N.C	N.c	No connection inside
24	MGNDA	Gnd	Motor A ground
25	OUTA1	O	Motor output A1
26	LED1	O	LED1 OUT (open drain)
27	LED2	O	LED2 OUT (open drain)
28	GNDD	Gnd	Ground pin for digital circuit
29	OSCIN	I	System clock input
30	DVDD	Power	Digital power supply
31	SOUT	O	SPI output
32	CS	I	SPI chip select
33	SCK	I	SPI clock input
34	SIN	I	SPI data in
35	VD_IS	I	Sync signal input for Iris
36	VD_FZ	I	Sync signal input for zoom&focus
37	PLS1	O	Pulse 1 output
38	PLS2	O	Pulse 2 output
39	RSTB	I	Reset signal input
40	GND A	Gnd	Ground pin for analog
41	CREFIN	IO	AVDD3/2 capacitor connection pin
42	VREF	O	Reference voltage for Hall sense
43	OP4INN	I	Amplifier 4 no-inverting input
44	OP4OUT	O	Amplifier 4 output

**Block Diagram :**

**Absolute Maximum Ratings:**

(over operating free-air temperature range (unless otherwise noted))

Symbol	Parameter	Rating	Unit
AVDD3	Analog supply voltage	-0.3~4.0	V
DVDD	Digital supply voltage	-0.3~4.0	V
MVCCA/B	STM motor supply voltage	-0.3~6.0	V
VDD5	DC motor supply voltage	-0.3~6.0	V
Topr	Operating ambient temperature	-40~100	°C
Tstg	Storage temperature	-55~125	°C
Istm	STM motor current	0.8	A
Idc	DC motor current	0.3	A
LED	LED pull down current	30	mA

ESD	Human Body Model	3000	V
-----	------------------	------	---

## Electrical Characteristics:

### Recommended Operating Conditions

Parameter	Symbol	Test Conditions	Min.	Typ.	Max.	Unit
Motor power supply	MVCCA,M VCCB,VD D5		3.0	5	5.5	V
Analog&Logic power supply	AVDD3,D VDD		2.7	3.3	3.6	V
Logic input Range	Vlogicin	TEST,OSCIN,CS,SCK,SIN, VD_IS,VD_FZ,RSTB	-0.3		DVDD+ 0.3	V
Logic output Range	Vlogicout	PLS1,PLS2,SOUT	-0.3		DVDD+ 0.3	V
Analog output Range	VAnalogout	OP3OUT,OP4OUT,SENS,V REF	-0.3		AVDD+ 0.3	V
Motor current	ISTM	OUTA1,OUTA2,OUTB1,OU TB2,OUTC1,OUTC2,OUTD 1,OUTD2	-0.25		+0.25	A
	IDC	OUTE1,OUTE2	-0.15		0.15	A
External constants	CVREF			100		pF
	CREFIN			0.1		uF
	RREF			10		kΩ
	COP3INP			0.01		uF
	COP4OUT				0.1	uF

Electrical Characteristics: (unless otherwise specified , T=25°C, DVDD=AVDD=3.3V, MVCCx=VDD5=5V)

Parameter	Symbol	Test Conditions	Min.	Typ.	Max.	Unit
MVCC current on Reset	Ivreset	No load, no 27MHz inputs,RSTB=0		0	2.0	uA
MVCC current	Ivmon	Output open		0.5	15	mA
DVDD,AVDD standby current	Ivddreset	no 27MHz inputs, RSTB=1		0	10	uA
DVDD,AVDD current	Ivddon	No load,RSTB=0		7	20	mA
VDD5 standby current	Ivdd5reset	no 27MHz inputs, RSTB=1		0	10	uA
VDD5 current	Ivdd5on	No load,RSTB=0		0.3	1	mA

### STM OUT H-bridge driver (focus&zoom)

Rdson,up+down4	RdsON1	Io=100mA;T=25°		1.5	2.5	Ω
When off leakage current	IOFF1	Vout=0V	-10		10	uA
<b>DC OUT H-bridge driver (Iris)</b>						
Rdson,up+down	RdsON2	Io=100mA;T=25°		2.0	3.0	Ω
When off leakage current	IOFF2	Vout=0V	-10		10	uA
<b>LED DRIVERS</b>						
Output on resistance	Rdson3				5	Ω
When off leakage current	IOFF2		-10		10	uAs
<b>Logic inputs/output</b>						
Input logic-low voltage	V <sub>IL</sub>	TEST,OSCIN,CS,SCK,SIN,VD_IS,VD_FZ,RSTB	-0.3	1.02	0.2*DVDD	V
Input logic-high voltage	V <sub>IH</sub>	TEST,OSCIN,CS,SCK,SIN,VD_IS,VD_FZ,RSTB	0.54*DVDD	1.36	DVDD+0.3	V
output logic-l voltage	V <sub>OH</sub>	PLS1,PLS2,SOUT,1mA Sink			0.5	V
Outpu logic-high voltage	V <sub>OL</sub>	PLS1,PLS2,SOUT,1mA Source	0.9*DVDD			
Pulldown resistance	R <sub>pd</sub>	RSTB		100		kΩ
<b>PROTECTION CIRCUITS</b>						
Over temperature protection	TSD		155	169	180	°C
Over temperature protection hysteresis	ΔTSD			26		°C
Under voltage lockout	V <sub>UVLO1</sub>	DVDD,AVDD		2.27		V
Under voltage lockout hysteresis	ΔV <sub>UVLO1</sub>	DVDD,AVDD		0.2		V
Under voltage lockout	V <sub>UVLO2</sub>	MVCCA,MVCCB,VDD5		2.20		V
Under voltage lockout hysteresis	ΔV <sub>UVLO2</sub>	MVCCA,MVCCB,VDD5		0.2		V
<b>OPAMP3 (HALL Sensor amplifier for output amplifier)</b>						
Input voltage range	V <sub>inop3</sub>	-	0.5*AVDD-0.5	0.5*AVDD	0.5*AVDD+0.5	V
Input offset voltage	VOF3	-	-15	-	15	mV
Output voltage(low)	VOL3	ILOAD=-100uA	-	0.1	0.2	V
Output voltage(high)	VOH3	ILOAD=100uA	AVDD-0.2	AVDD-0.1	-	V
Gain	VOG	Gain register set value: 0h	19.7	21.9	24.1	V/V
<b>OP4AMP4 (HALL sensor amplifier for eliminating common-mode voltage)</b>						
Input voltage range	V <sub>inop4</sub>	-	0.5*AVDD-0.1	0.5*AVDD	0.5*AVDD+0.1	V
Input offset voltage	VOF4	-	-10	-	10	mV
Output voltage(low)	VOL4	ILOAD=-100uA	-	0.1	0.2	V

Output voltage(high)	VOH4	ILOAD=100uA	AVDD -0.5	AVDD -0.2	-	V
<b>Reference output</b>						
Output voltage 1	VREF	VCREF=100pF; ILOAD=0A	0.5*AV DD-0.1	0.5*AV DD	0.5*AV DD+0.1	V
Output voltage 1	VREFL	VCREF=100pF; ILOAD=100uA	VREF -0.1	VREF	VREF +0.1	V
<b>Hall bias controller (SENS output)</b>						
Minutes output current	IBL	REF=10kΩ, SENS=0.7V, set value:00h	-	0	0.1	mA
Output current accuracy1	IB 40H	REF=10kΩ, SENS=0.7V, set value:40h	0.9	1.02	1.14	mA
Output current accuracy2	IB BEH	REF=10kΩ, SENS=0.7V, set value:BEh	2.66	3.02	3.38	mA
<b>8bit DAC for Hall offset adjustment</b>						
Adjustment range high	DAoutH	-		AVDD3		V
Adjustment range high	DAoutL	-		0		V
<b>10bit ADC</b>						
Input voltage range high	Vinhigh	-	-	-	AVDD3 -0.2	V
Input voltage range low	Vinlow	-	0.2	-	-	V
Differential linearity error	DNL	-	-	1.0	-	LSB
Intergral linearity error	INL		-	2.0	-	LSB

## Function description

### (1)Serial interface

Timing chart:

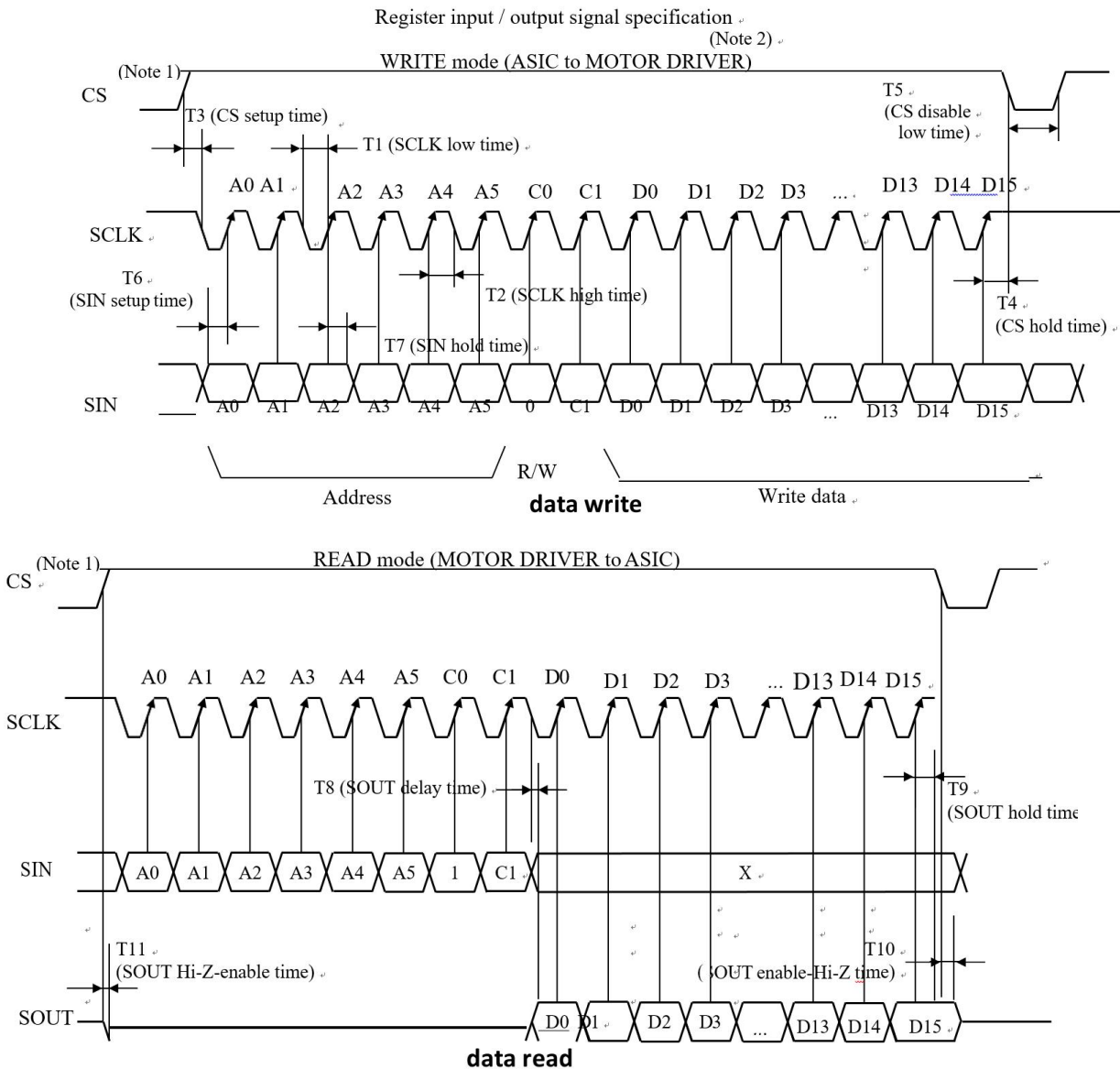

TA = 25°C, VCC = 5 V, RL = 20 Ω

Parameter	condition	range		Unit
		Min	Max	
SPI Speed	Serial clock	1	5	MHz
T1	SCLK low time	100	-	ns
T2	SCLK high time	100	-	ns
T3	CS setup time	60	-	ns



T4	CS hold time	60		ns
T5	CS disable low time	100		ns
T6	SIN setup time	50		ns
T7	SIN HOLD time	50	-	ns
T8	SOUT delay time	-	60	us
T9	SOUT hold time	60		ns
T10	SOUT enable-Hiz time	-	60	ns
T11	SOUT Hiz-enable time	-	60	ns
Cload	SOUT Capacitor load	-	40	pF

**(2) register map**

	D15	D14	D13	D12	D11	D10	D9	D8	D7	D6	D5	D4	D3	D2	D1	D0
00H							IRS_TGT[9:0]									
01H	DGAIN[6:0]						ASOUNDLPF_FC[2:0]		AS_FLT_ OFF	DEC_A VE	OVER_LPF_FC_ 2ND[1:0]	OVER_LPF_FC_ 1ST[1:0]				
02H	PID_POLE[3:0]			PID_ZERO[3:0]				IRIS_ROUND[3:0]			IRIS_CALC_NR[3:0]					
03H			DT_ADJ_IRI S[1:0]	PWM_IRIS [2:0]			PWM_LPF_FC[2:0]		PWM_FLT OFF	LMT_E NB	ARW[3:0]					
04H	HALL_OFFSET_DAC[7:0]							HALL_BIAS_DAC[7:0]								
05H				AAF _FC	HALL_GAIN[3:0]						PID_ INV	TGT_F LT_OF F	TGT_LPF_FC[3:0]			
06H							START1[9:0]									
07H	P1EN	WIDTH1[11:0]														
08H							START2[9:0]									
09H	P2EN	WIDTH2[5:0]														
0AH						DUTY_ TEST	TGT_IN_TEST[9:0]									
0BH	PID_CLIP[3:0]				ADC_ TEST	PDWN B	MODES EL_FZ	MODESE L_IRIS	TESTE N1			ASWMODE[1:0]				
0CH							IRSAD[9:0] (Read Only)									
0EH				AVE_SPEED[4:0]				TGT_UPDATE[7:0]								
20H		PWMRES[1: 0]	PWMMODE[4:0]				DT1[7:0]									
21H									TESTE N2			FZTEST[4:0]				
22H			PHMODAB[5:0]				DT2A[7:0]									
23H			PPWB[7:0]				PPWA[7:0]									
24H			MICROAB [1:0]	LEDB	ENDIS AB	BRAKE AB	CCWCW AB	PSUMAB[7:0]								
25H	INTCTAB[15:0]															
27H			PHMODCD[5:0]				DT2B[7:0]									
28H			PPWD[7:0]				PPWC[7:0]									
29H			MICROCD [1:0]	LEDA	ENDIS CD	BRAKE CD	CCWCW CD	PSUMCD[7:0]								
2AH	INTCTCD[15:0]															

**(3) register description**

Address	Register	Function	
00h	IRS_TGT[9:0]	Iris target position Expressed in 10 bit digits	
01h	OVER_LPF_FC_1ST[1:0]	ADC feedback filter (1) cut-off frequency	
	OVER_LPF_FC_2ND[1:0]	ADC feedback filter (2) cut-off frequency	
	DEC_AVE	Moving average to Iris target position	
	AS_FLT_OFF	Filter before PID controller enable / disable	
	ASOUND_LPF_FC[2:0]	Filter cut-off frequency before PID controller	
	DGAIN[6:0]	PID controller digital gain	
02h	IRIS_CALC_NR[3:0]	PID integral error cumulative prevention level	
	IRIS_ROUND[3:0]	PID differential error cumulative prevention level	
	PID_ZERO[3:0]	PID controller zero point	
	PID_POLE[3:0]	PID controller pole	
03h	ARW[3:0]	Number of bits in PID controller integrator	
	LMT_ENB	PID controller integral stop	
	PWM_FLT_OFF	LPF after PID controller enable / disable	
	PWM_LPF_FC[2:0]	LPF cut-off frequency after PID controller	
	PWM_IRIS[2:0]	PWM frequency of Iris block output	
	DT_ADJ_IRIS[1:0]	Dead time correction of Iris block output	
04h	HALL_BIAS_DAC[7:0]	Drive current value for hall element	
	HALL_OFFSET_DAC[7:0]	Offset adjustment for hall element output amplifier	
05h	TGT_LPF_FC[3:0]	Iris target value LPF cut-off frequency	
	TGT_FLT_OFF	Iris target value LPF function enable / disable	
	PID_INV	PID controller polarity	
	HALL_GAIN[3:0]	Hall element output amplifier gain	
	AAF_FC	Cut-off frequency of hall element output amplifier	
06h	START1[9:0]	Pulse 1 start time	
07h	WIDTH1[11:0]	Pulse 1 width	
	P1EN	Pulse 1 output enable	
08h	START2[9:0]	Pulse 2 start time	
09h	WIDTH2[5:0]	Pulse 2 width	

	P2EN	Pulse 2 output enable	
0Ah	TGT_IN_TEST[9:0]	Iris output duty direct specified value	
	DUTY_TEST	Iris output duty direct specification enable	
0Bh	ASWMODE[1:0]	ADTESTIN pin connection selection	
	TESTEN1	Test mode enable 1	
	MODESEL_IRIS	VD_IS polarity selection	
	MODESEL_FZ	VD_FZ polarity selection	
	PDWNB	Power down of Iris block	
	ADC_TEST	ADC read value updated timing	
	PID_CLIP[3:0]	Iris output PWM maximum duty	
0Ch	IRSAD[9:0]	ADC output for Iris (read only)	
0Eh	TGT_UPDATE[7:0]	IRS_TGT (iris target) update delay time	
	AVE_SPEED[4:0]	Iris target moving average speed	
20h	DT1[7:0]	Start point wait time	
	PWMODE[4:0]	Micro step output PWM frequency	
	PWMRES[1:0]	Micro step output PWM resolution	
21h	FZTEST[4:0]	PLS1/2 pin output signal selection	
	TESTEN2	Test mode enable 2	
22h	DT2A[7:0]	$\alpha$ motor start point excitation wait time	
	PHMODAB[5:0]	$\alpha$ motor phase correction	
23h	PPWA[7:0]	Driver A peak pulse width	
	PPWB[7:0]	Driver B peak pulse width	
24h	PSUMAB[7:0]	$\alpha$ motor step count number	
	CCWCWAB	$\alpha$ motor rotation direction	
	BRAKEAB	$\alpha$ motor brake	
	ENDISAB	$\alpha$ motor enable/disable control	
	LEDB	LED B output control	
	MICROAB[1:0]	$\alpha$ motor sine wave division number	
25h	INTCTAB[15:0]	$\alpha$ motor step cycle	
27h	DT2B[7:0]	$\beta$ motor start point excitation wait time	
	PHMODCD[5:0]	$\beta$ motor phase correction	
28h	PPWC[7:0]	Driver C peak pulse width	
	PPWD[7:0]	Driver D peak pulse width	
29h	PSUMCD[7:0]	$\beta$ motor step count number	
	CCWCWCD	$\beta$ motor rotation direction	

	BRAKECD	$\beta$ motor brake	
	ENDISCD	$\beta$ motor enable/disable control	
	LEDA	LED A output control	
	MICROCD[1:0]	$\beta$ motor sine wave division number	
2Ah	INTCTCD[15:0]	$\beta$ motor step cycle	

Typical Application

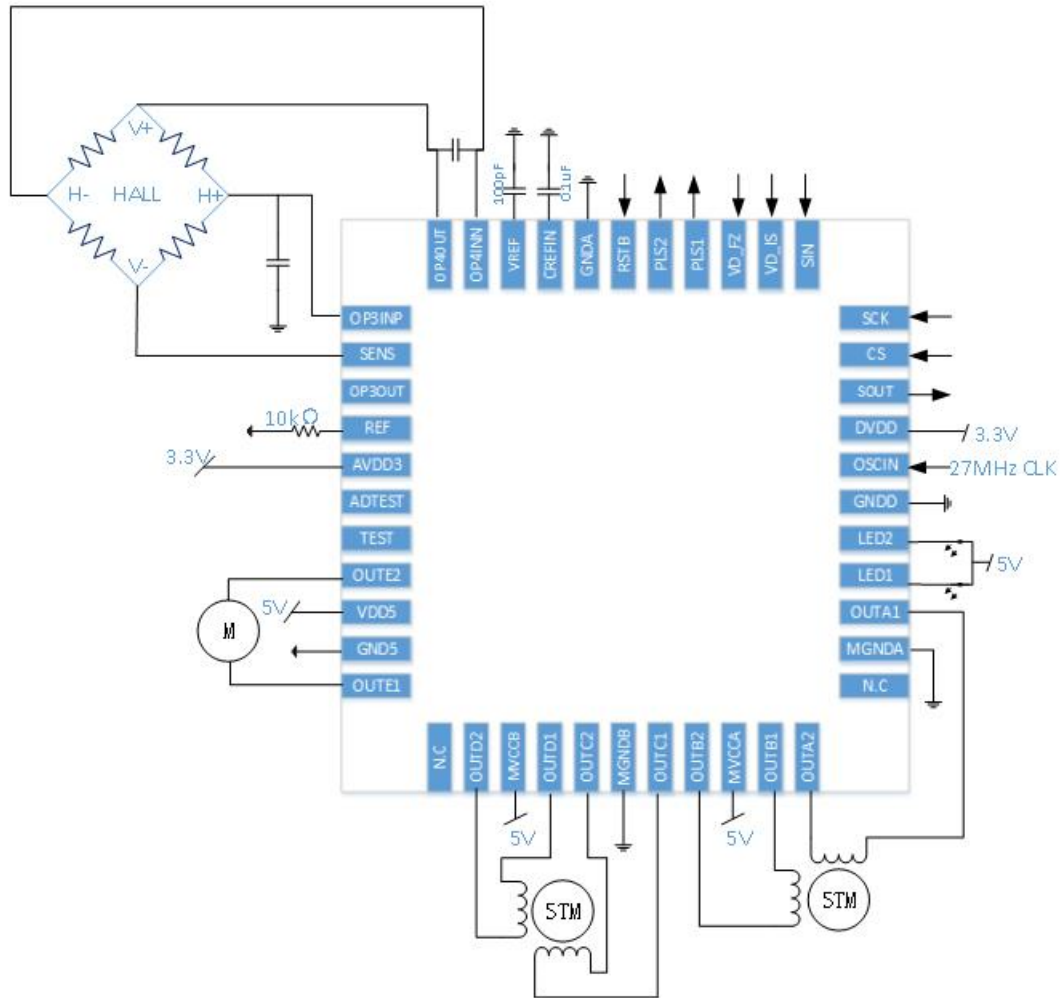

GC6208 typical application

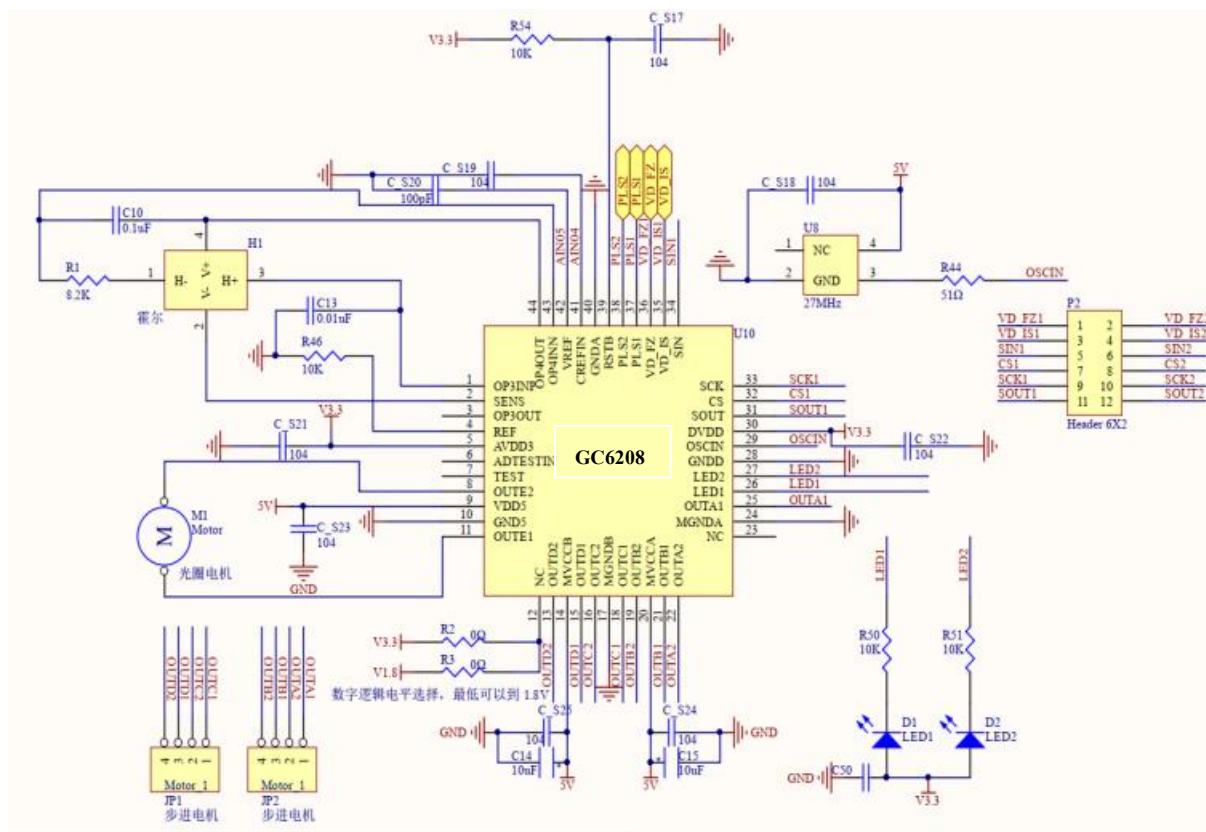

GC6208 PCB schematic

**Package Information**
