



Features

- 1.2kV Schottky Rectifier
- Zero Reverse Recovery Current
- High-Frequency Operation
- Temperature-Independent Switching
- Extremely Fast Switching

Benefits

- Replace Bipolar with Unipolar Rectifiers
- Essentially No Switching Losses
- Higher Efficiency
- Reduction of Heat Sink Requirements
- Parallel Devices Without Thermal Runaway

Applications

- Switch Mode Power Supplies (SMPS)
- Boost diodes in PFC or DC/DC stages
- Free Wheeling Diodes in Inverter stages
- AC/DC converters

Part Number	Package
GC4D60120D	TO-247-3

V_{RRM}	=	1200 V
$I_F (T_C=135^\circ\text{C})$	=	76A
Q_C	=	198nC

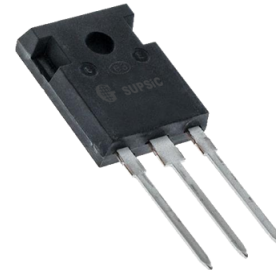

TO-247-3

Package

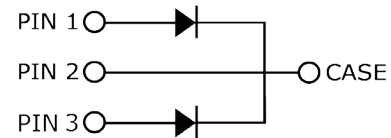

Maximum Ratings ($T_C=25^\circ\text{C}$ unless otherwise specified)

Parameter	Symbol	Conditions	Values	Unit	Note
Repetitive Peak Reverse Voltage (Per Leg)	V_{RRM}		1200	V	
Continuous Forward Current (Per Leg / Per Device)	I_F	$T_C = 100^\circ\text{C}, D = 1$	55 / 110	A	Fig. 4
		$T_C = 135^\circ\text{C}, D = 1$	38 / 76		
		$T_C = 148^\circ\text{C}, D = 1$	30 / 60		
Non-Repetitive Peak Forward Surge Current, Half Sine Wave (Per Leg)	I_{FSM}	$T_C = 25^\circ\text{C}, t_P = 10 \text{ ms}$	240	A	
		$T_C = 150^\circ\text{C}, t_P = 10 \text{ ms}$	192		
Repetitive Peak Forward Surge Current, Half Sine Wave (Per Leg)	I_{FRM}	$T_C = 25^\circ\text{C}, t_P = 10 \text{ ms}$	144	A	
		$T_C = 150^\circ\text{C}, t_P = 10 \text{ ms}$	100		
Non-Repetitive Peak Forward Surge Current (Per Leg)	I_{FMAX}	$T_C = 25^\circ\text{C}, t_P = 10 \mu\text{s}$	1200	A	
i^2t Value (Per Leg)	$\int i^2 dt$	$T_C = 25^\circ\text{C}, t_P = 10 \text{ ms}$	288	A^2s	
Non-Repetitive Avalanche Energy (Per Leg)	E_{AS}	$L = 0.6 \text{ mH}, I_{AS} = 30 \text{ A}$	271	mJ	
Diode Ruggedness (Per Leg)	dV/dt	$V_R = 0 \sim 960 \text{ V}$	200	V/ns	
Power Dissipation (Per Leg / Per Device)	P_{TOT}	$T_C = 25^\circ\text{C}$	313 / 626	W	Fig. 3
Operating and Storage Temperature	T_j, T_{stg}		-55 to 175	$^\circ\text{C}$	

* Per Device

Electrical Characteristics (Per Leg)

Symbol	Parameter	Typ.	Max.	Unit	Test Conditions	Note
V_F	Forward Voltage	1.5 1.9	1.8 2.5	V	$I_F = 30\text{ A}$ $T_j = 25^\circ\text{C}$ $I_F = 30\text{ A}$ $T_j = 175^\circ\text{C}$	Fig. 1
I_R	Reverse Current	2 20	20	μA	$V_R = 1200\text{ V}$ $T_j = 25^\circ\text{C}$ $V_R = 1200\text{ V}$ $T_j = 175^\circ\text{C}$	Fig. 2
Q_C	Total Capacitive Charge	97		nC	$V_R = 800\text{ V}$, $I_F = 30\text{ A}$ $di/dt = 200\text{ A}/\mu\text{s}$ $T_j = 25^\circ\text{C}$	Fig. 7
C	Total Capacitance	1101 64		pF	$V_R = 0\text{ V}$, $T_j = 25^\circ\text{C}$, $f = 1\text{ MHz}$ $V_R = 800\text{ V}$, $T_j = 25^\circ\text{C}$, $f = 1\text{ MHz}$	Fig. 6

Note: This is a majority carrier diode, so there is no reverse recovery charge.

Thermal Characteristics

Symbol	Parameter	Typ.	Unit	Note
$R_{\theta JC}$	Thermal Resistance from Junction to Case	0.48	$^\circ\text{C}/\text{W}$	Fig. 9

Typical Performance (Per Leg)

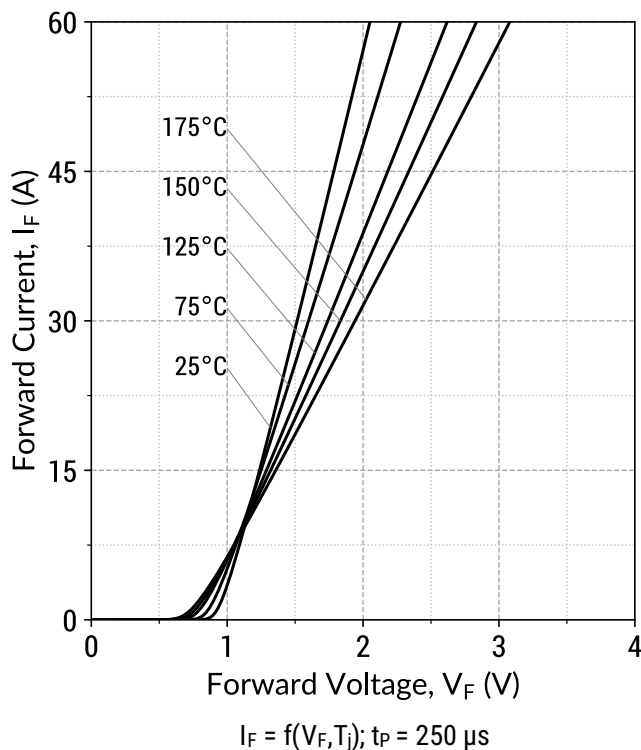

Figure 1: Typical Forward Characteristics (Per Leg)

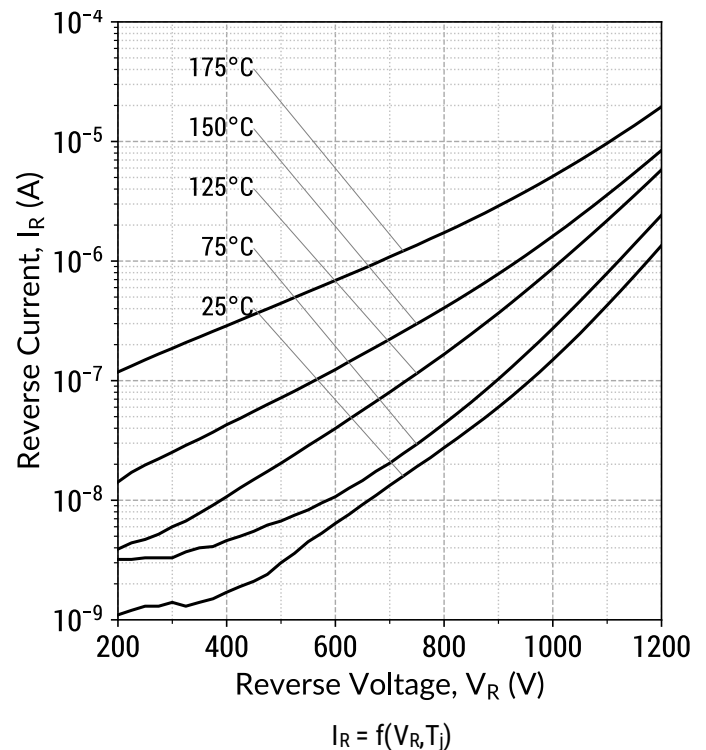
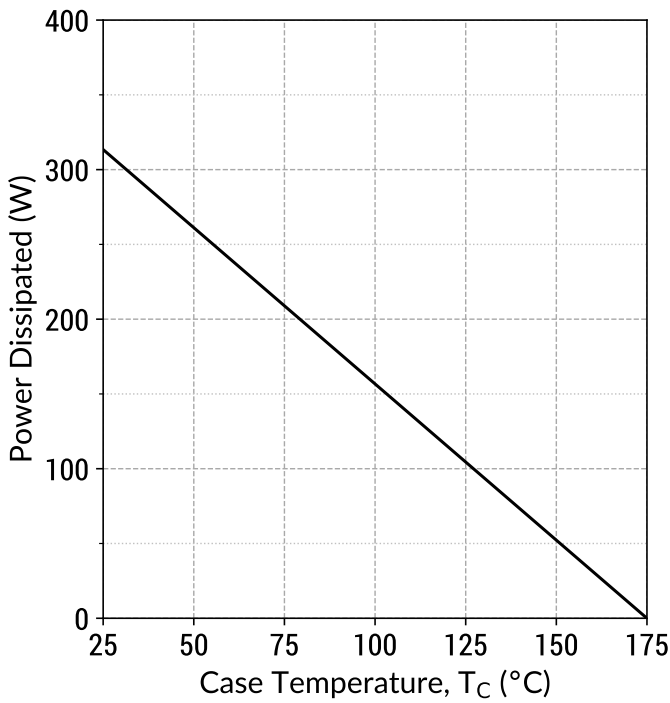
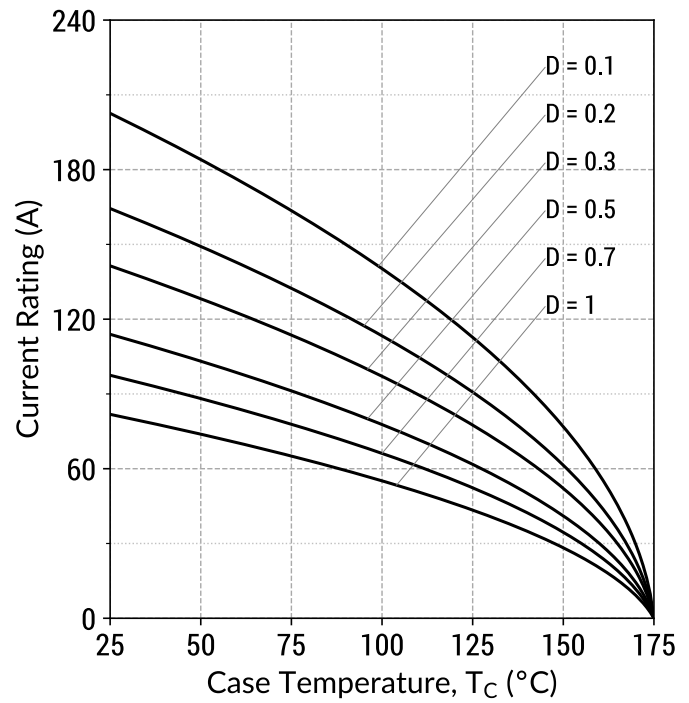

Figure 2: Typical Reverse Characteristics (Per Leg)



$$P_{TOT} = f(T_C); T_j = 175^\circ\text{C}$$

Figure 3: Power Derating Curves (Per Leg)



$$I_F = f(T_C); D = t_P/T; T_j \leq 175^\circ\text{C}; f_{sw} > 10\text{kHz}$$

Figure 4: Current Derating Curves (Typical V_F) (Per Leg)

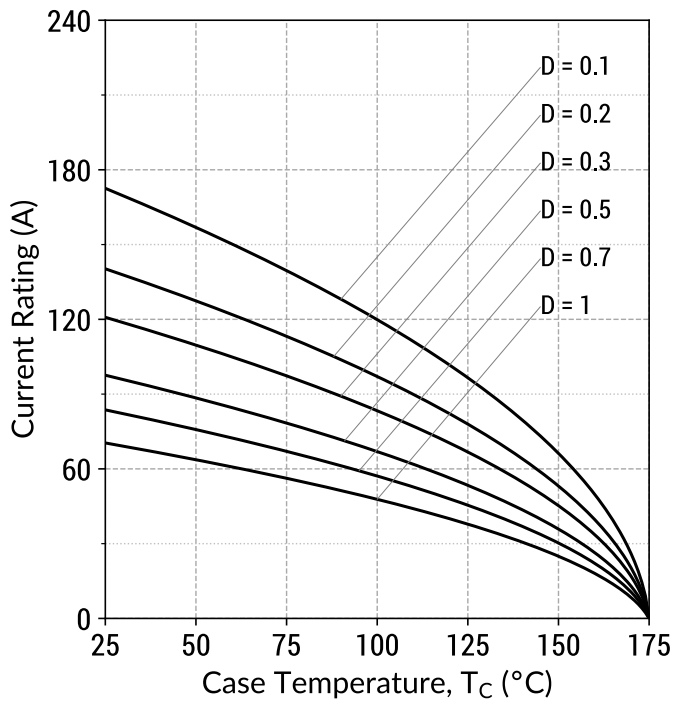

$$I_F = f(T_C); D = t_P/T; T_j \leq 175^\circ\text{C}; f_{sw} > 10\text{kHz}$$

Figure 5: Current Derating Curves (Maximum V_F) (Per Leg)

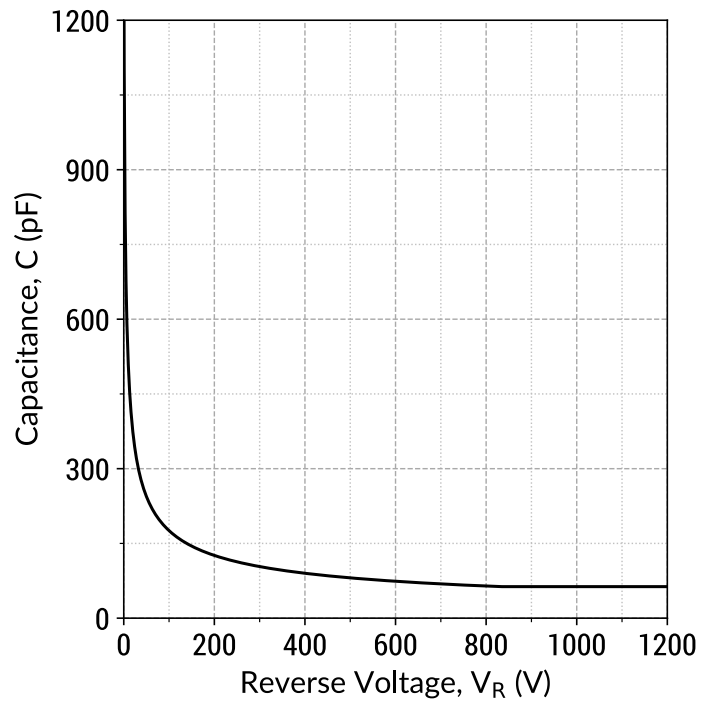

$$C = f(V_R); f = 1\text{MHz}$$

Figure 6: Typical Junction Capacitance vs Reverse Voltage Characteristics (Per Leg)

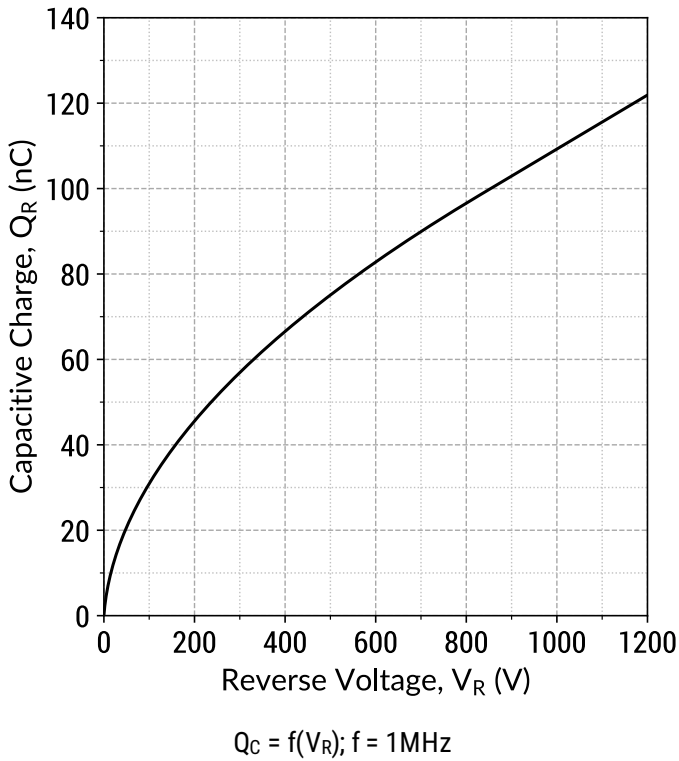

Figure 7: Typical Capacitive Charge vs Reverse Voltage Characteristics (Per Leg)

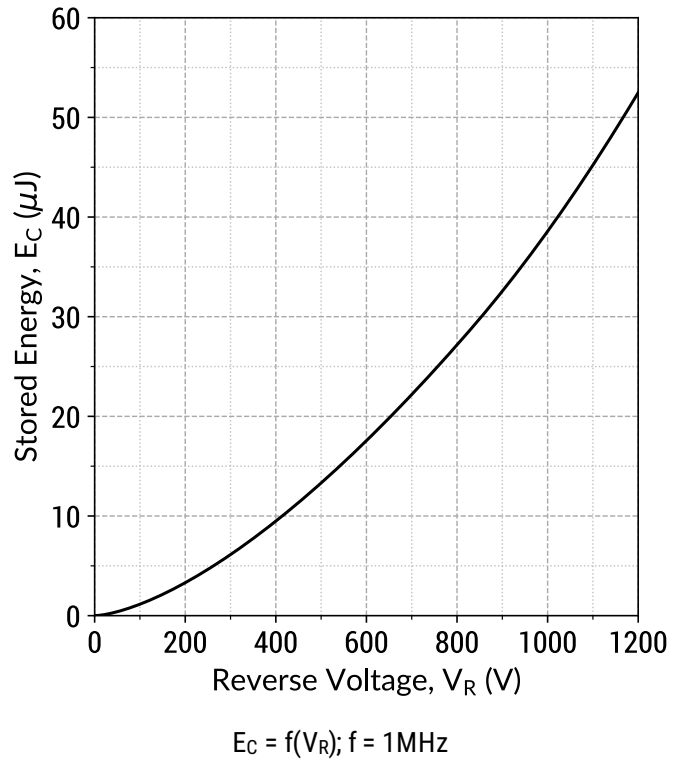

Figure 8: Typical Capacitive Energy vs Reverse Voltage Characteristics (Per Leg)

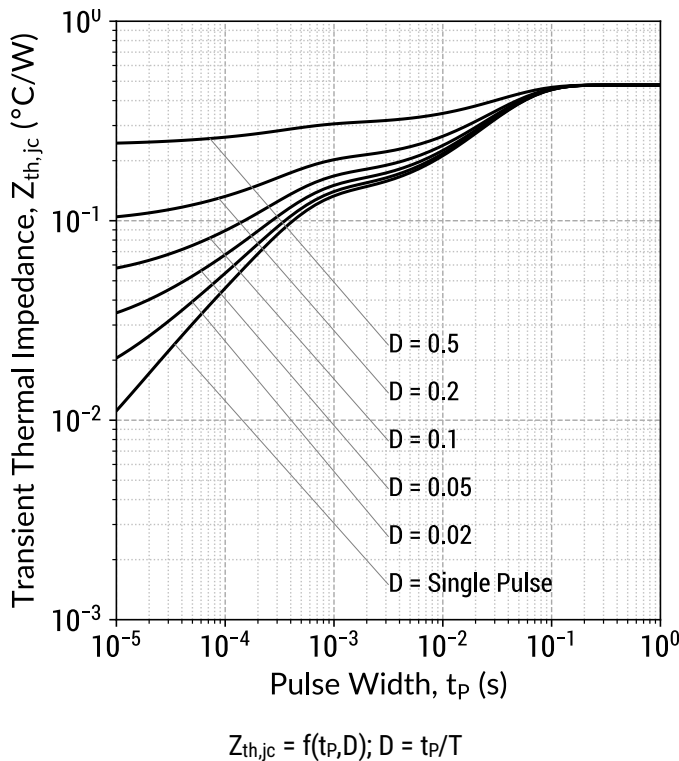

Figure 9: Transient Thermal Impedance (Per Leg)

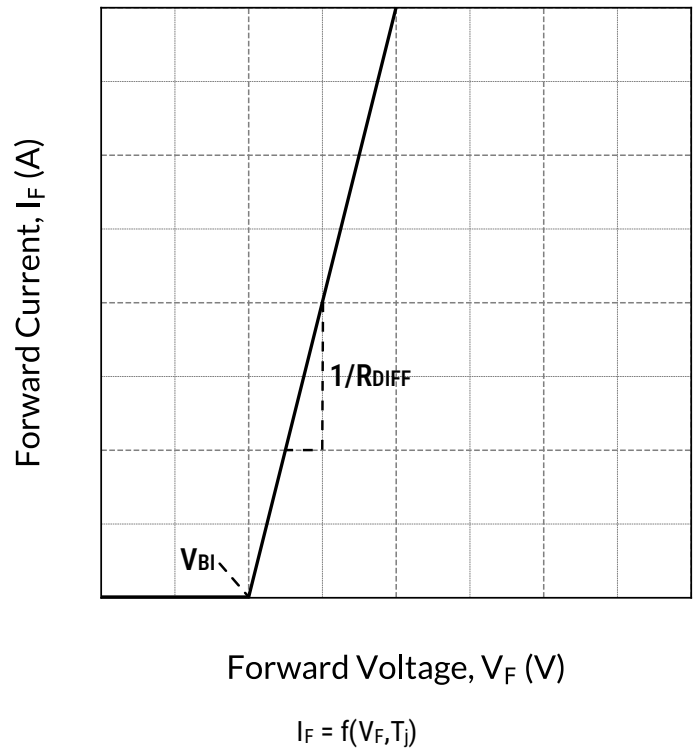

Figure 10: Forward Curve Model (Per Leg)

Forward Curve Model Equation:

$$I_F = (V_F - V_{BI})/R_{DIFF} \text{ (A)}$$

Built-In Voltage (V_{BI}):

$$V_{BI}(T_j) = m \times T_j + n \text{ (V)}$$

$$m = -0.00119 \text{ (V/°C)}$$

$$n = 1.01 \text{ (V)}$$

Differential Resistance (R_{DIFF}):

$$R_{DIFF}(T_j) = a \times T_j^2 + b \times T_j + c \text{ (}\Omega\text{)}$$

$$a = 3.97e-07 \text{ (}\Omega\text{/°C}^2\text{)}$$

$$b = 5.5e-05 \text{ (}\Omega\text{/°C)}$$

$$c = 0.0163 \text{ (}\Omega\text{)}$$

Forward Power Loss Equation:

$$P_{LOSS} = V_{BI}(T_j) \times I_{AVG} + R_{DIFF}(T_j) \times I_{RMS}^2$$

Package Dimensions

Package TO-247-3

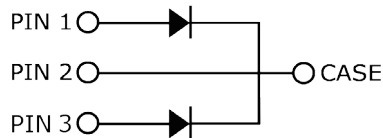
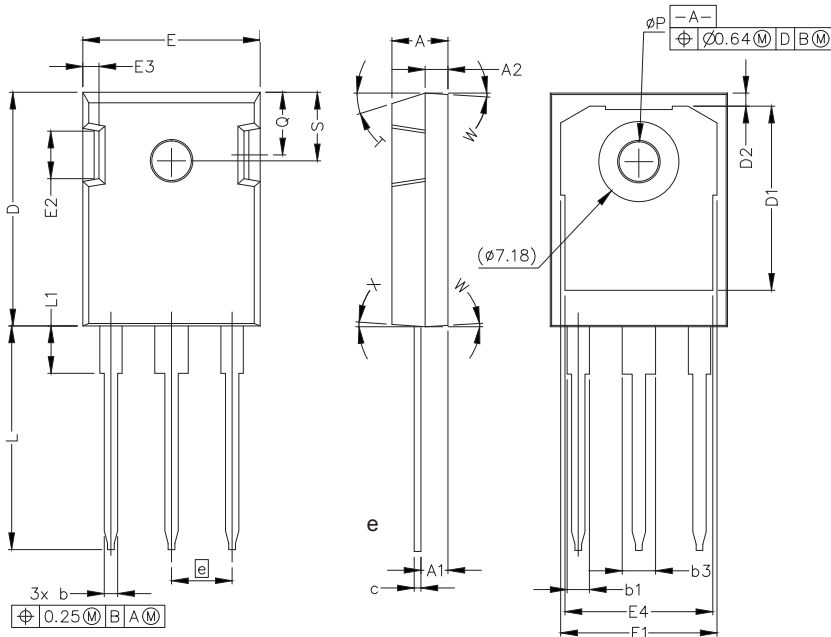

POS	Inches		Millimeters	
	Min	Max	Min	Max
A	.190	.205	4.83	5.21
A1	.090	.100	2.29	2.54
A2	.075	.085	1.91	2.16
b	.042	.052	1.07	1.33
b1	.075	.095	1.91	2.41
b3	.113	.133	2.87	3.38
c	.022	.027	0.55	0.68
D	.819	.831	20.80	21.10
D1	.640	.695	16.25	17.65
D2	.037	.049	0.95	1.25
E	.620	.635	15.75	16.13
E1	.516	.557	13.10	14.15
E2	.145	.201	3.68	5.10
E3	.039	.075	1.00	1.90
E4	.487	.529	12.38	13.43
e	.214 BSC		5.44 BSC	
L	.780	.800	19.81	20.32
L1	.161	.173	4.10	4.40
N	3			
ØP	.138	.144	3.51	3.65
Q	.216	.236	5.49	6.00
S	.238	.248	6.04	6.30
T	17.5° REF			
W	3.5° REF			
X	4° REF			

Recommended Solder Pad Layout

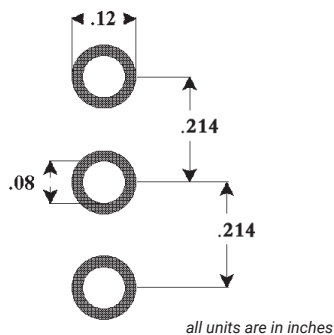

Part Number	Package
GC4D60120D	TO-247-3