



80x80x25 mm

San Ace 80W 9WP type

General Specifications

- Material Frame: Plastic (Flammability: UL 94V-0), Impeller: Plastic (Flammability: UL 94V-1)
- Expected life See the table below. (L10 life: 90% survival rate for continuous operation in indoor free air at 60°C, rated voltage) Expected life at 40°C is for reference only.
- Motor protection function Locked rotor burnout protection, Reverse polarity protection For details, please refer to p. 599.
- Dielectric strength 50/60 Hz, 500 VAC, for 1 minute (between lead wire conductors and frame)
- Insulation resistance 10 MΩ or more with a 500 VDC megger (between lead wire conductors and frame)
- Sound pressure level (SPL) At 1 m away from the air inlet
- Storage temperature -30 to +70°C (Non-condensing)
- Lead wire ⊕Red ⊖Black (Sensor) Yellow
- Mass 130 g
- Ingress protection IP68

Specifications

The models listed below **have ribs and pulse sensors**. For models without ribs, append "1" to the end of model numbers.

Model no.	Rated voltage [V]	Operating voltage range [V]	Rated current [A]	Rated input [W]	Rated speed [min ⁻¹]	Max. airflow [m ³ /min] [CFM]	Max. static pressure [Pa] [inchH ₂ O]	SPL [dB (A)]	Operating temperature [°C]	Expected life [h]
9WP0812G401	12	10.8 to 13.2	0.38	4.56	4500	1.5 53	80.4 0.323	40	-20 to +60	40000/60°C (70000/40°C)
9WP0812H401		10.2 to 13.8	0.13	1.56	2900	1.03 36.4	35.3 0.142	29		60000/60°C (90000/40°C)
9WP0824S401	24	20.4 to 27.6	0.1	2.4	3400	1.2 42.4	48.0 0.193	34		40000/60°C (70000/40°C)
9WP0824H401			0.07	1.68	2900	1.03 36.4	35.3 0.142	29		60000/60°C (90000/40°C)
9WP0848S401	48	40.8 to 55.2	0.06	2.88	3400	1.2 42.4	48.0 0.193	34		40000/60°C (70000/40°C)

Note: Sensor and control options are available for selection. Refer to the table on p. 639.

Airflow - Static Pressure Characteristics

9WP0812G401 With pulse sensor

Operating voltage range

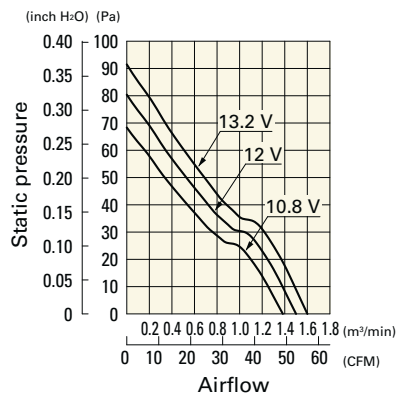

9WP0812H401 With pulse sensor

Operating voltage range

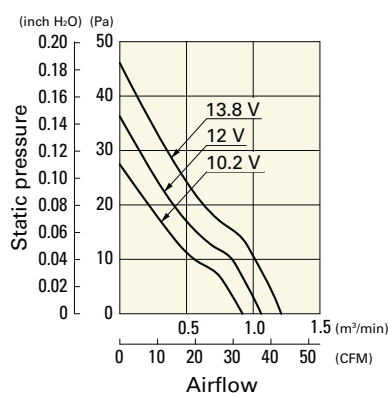

9WP0824S401 With pulse sensor

Operating voltage range

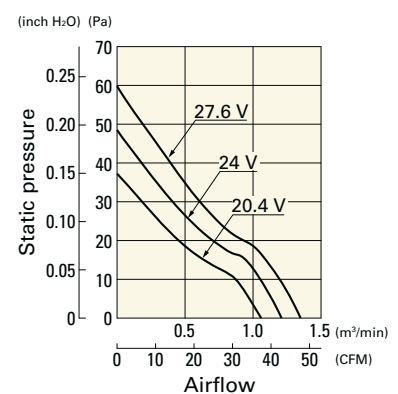

Airflow - Static Pressure Characteristics

9WP0824H401 With pulse sensor

9WP0848S401 With pulse sensor

Operating voltage range

Operating voltage range

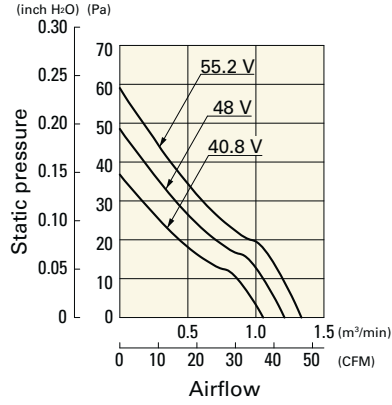
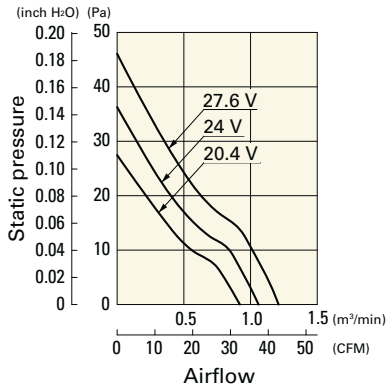

Dimensions (unit: mm) (With ribs)

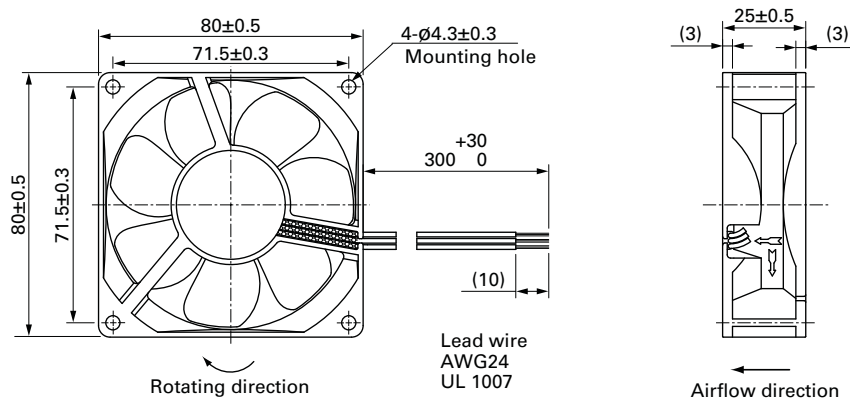

Reference Dimensions of Mounting Holes and Vent Opening (unit: mm)

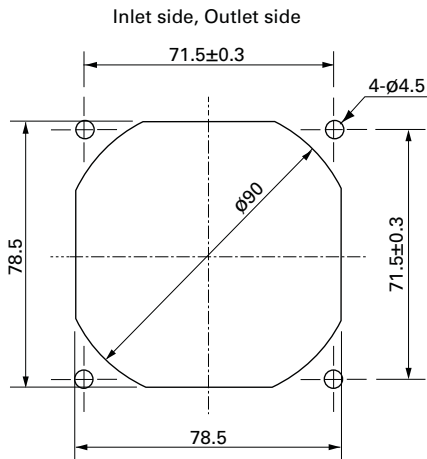

Options

Finger guards

page: p. 584

Model no.: 109-049E, 109-049H, 109-049C

Resin finger guards

page: p. 591

Model no.: 109-1002G