

REV.	ECN.	NO.	APPD.
X1			Davy Bu 10/22/14
X2			Davy Bu 12/8/14

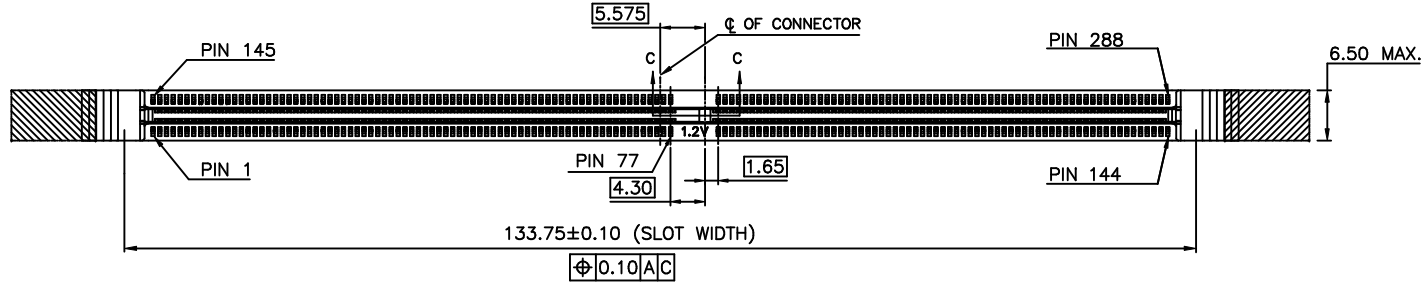

- NOTES: UNLESS OTHERWISE SPECIFIED:
 1. ALL DIMENSIONS ARE IN MILLIMETER.
 2. INTERPRET DRAWINGS PER ASME Y14.5M-1994
 3. REFLOW TEMPERATURE & TIME: 260°C & 10s

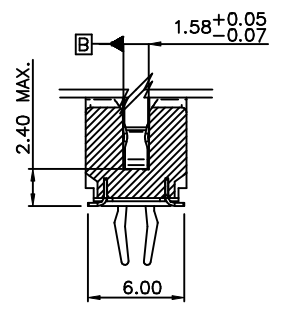
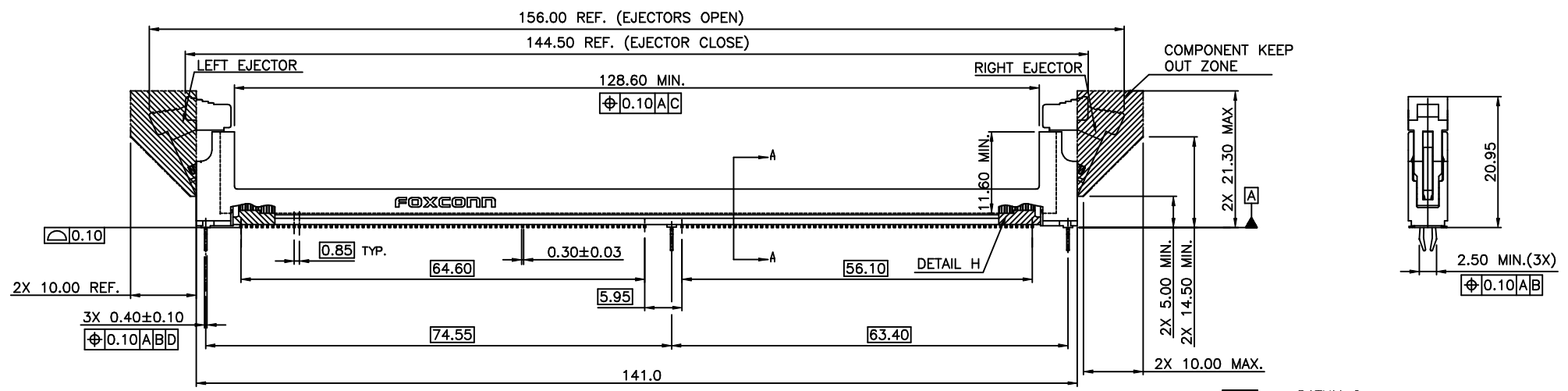

SECTION A-A
SCALE 2:1

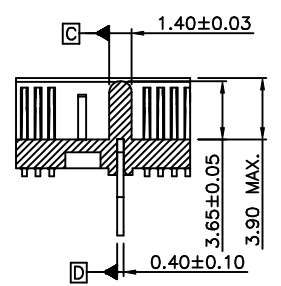

SECTION C-C
SCALE 2:1

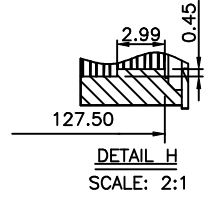

DETAIL H
SCALE: 2:1

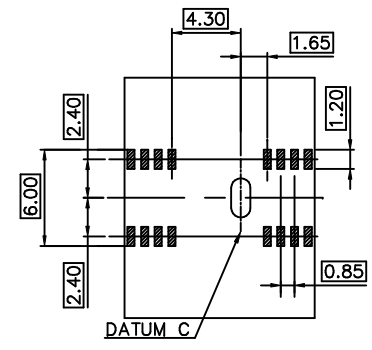

OUTER LOCUS OF CONNECTOR SMT LEADS
SCALE 2:1

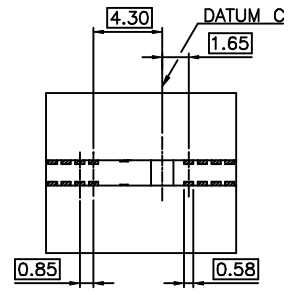

OUTER LOCUS OF CONTACT PIN FROM POSITION TOLERANCE AND FEATURE SIZE (BOUNDING WIDTH)
OUTER LOCUS OF CONNECTOR CONTACT PIN

X.±	X.±	UNITS	mm	NAME(INTENDED USE)	FOXCONN® FOXCONN INTERCONNECT TECHNOLOGY LIMITED
.X± 0.25	.X±	MAT'L	N/A	DDR 4, 288 PIN 0.85mm PITCH, SMT	
.XX± 0.15	.XX±	FINISH	N/A	PART NO.(INTENDED USE)	CLASS: <input type="checkbox"/> CONFIDENTIAL <input type="checkbox"/> SECRET <input checked="" type="checkbox"/> GENERAL
.XXX±	.XXX±	Q'TY	N/A	AH588**-T****0-**	TITLE:CUSTOMER DRAWING
THESE DRAWINGS AND SPECIFICATIONS ARE THE PROPERTY OF FOXCONN PRECISION IND. CO., LTD. AND SHALL NOT BE REPRODUCED, COPIED OR USED IN ANY MANNER WITHOUT THE PRIOR WRITTEN CONSENT OF FOXCONN PRECISION IND. CO., LTD.				APPD: Davy Bu 12/8/14	DWG NO.: 317-0000-2381
				CHKD: Johnny Tang 12/8/14	SCALE SHEET REV. N/A 1/5 X2
				DR: Sudong Li 12/8/14	

PART NUMBER	POSITION	MARKING	DIM.A HOOK LENGTH	DIM.B TAB LENGTH	TYPE
AH5889*-T9**0-**	288	1.2V	3.78 ±0.25	/	A
AH5888*-TC**0-**	288	1.2V	3.78 ±0.25	2.60	B
AH5889*-TC**0-**	288	1.2V	3.78 ±0.25	1.90	B
AH5888*-T2**0-**	288	1.2V	/	2.60	C
AH5889*-T2**0-**	288	1.2V	/	1.90	C

REV.	ECN.	NO.	APPD.
SEE SHEET 1/5			

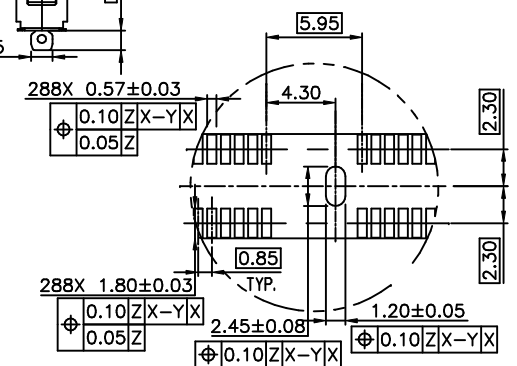
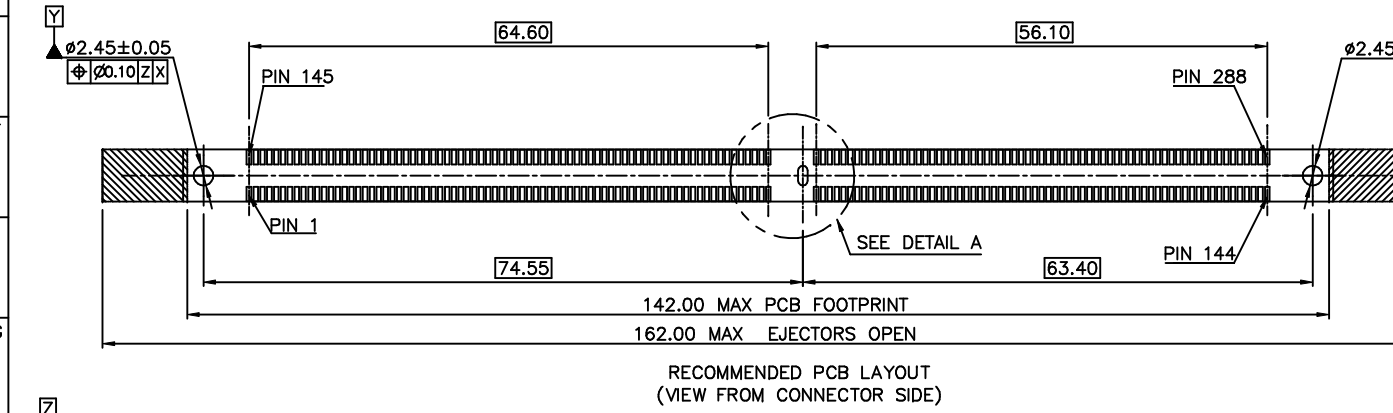
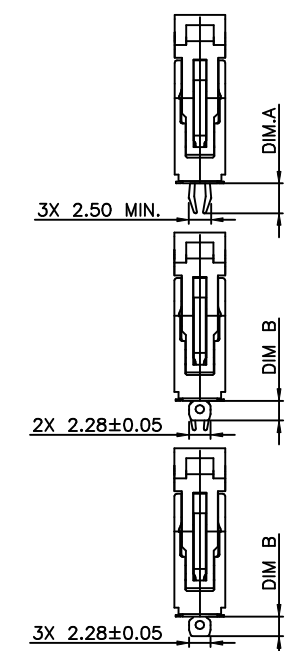
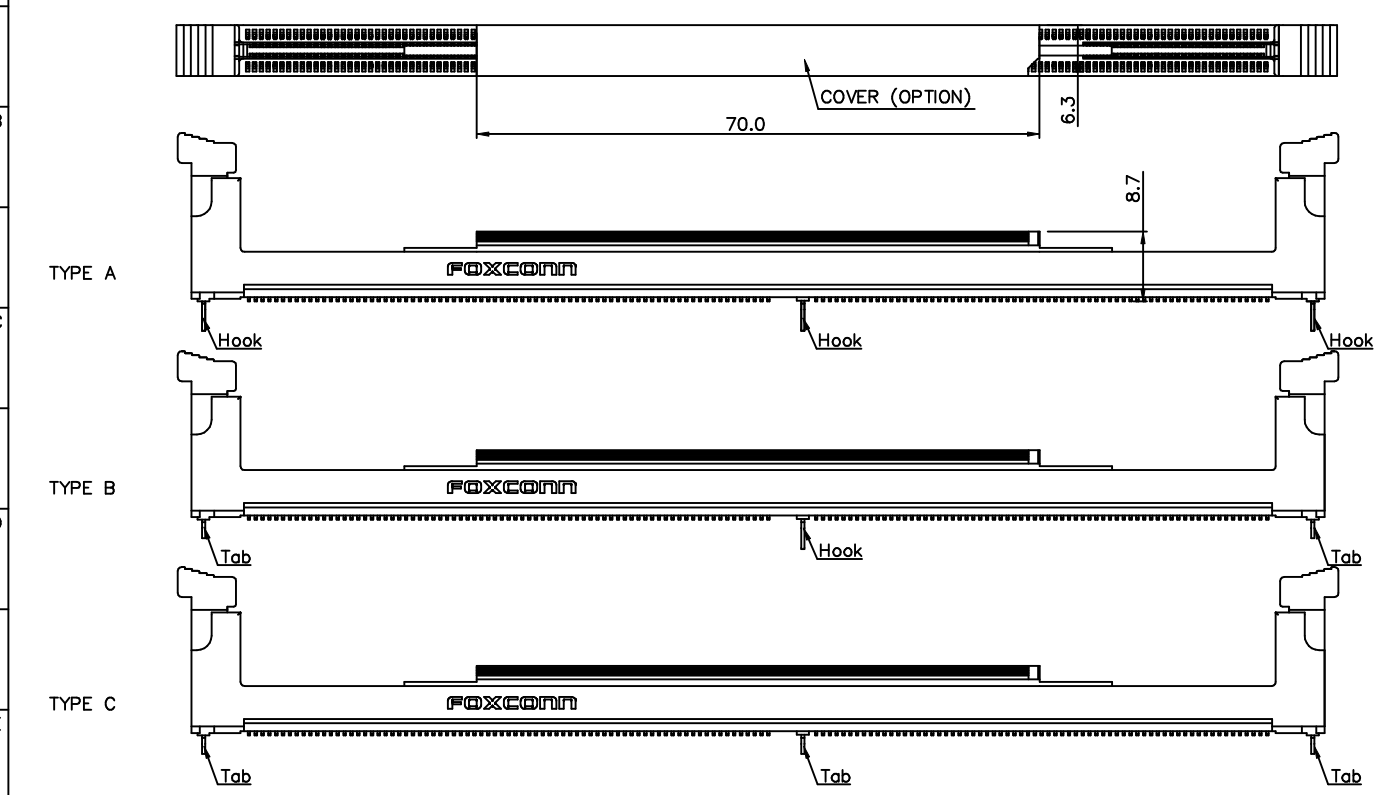

X.±	X.±	UNITS	mm	NAME(INTENDED USE)	FOXCONN FOXCONN INTERCONNECT TECHNOLOGY LIMITED
.X± 0.25	.X±	MATL	N/A	DDR 4, 288 PIN 0.85mm PITCH, SMT	
.XX± 0.15	.XX±	FINISH	N/A	PART NO.(INTENDED USE) AH588**-T***0-**	CLASS: <input type="checkbox"/> CONFIDENTIAL <input type="checkbox"/> SECRET <input checked="" type="checkbox"/> GENERAL
.XXX±	.XXX±	Q'TY	N/A	APPD: Davy Bu 12/8'14	TITLE: CUSTOMER DRAWING
THESE DRAWINGS AND SPECIFICATIONS ARE THE PROPERTY OF FOXCONN PRECISION IND. CO., LTD. AND SHALL NOT BE REPRODUCED, COPIED OR USED IN ANY MANNER WITHOUT THE PRIOR WRITTEN CONSENT OF FOXCONN PRECISION IND. CO., LTD.				CHKD: Johnny Tang 12/8'14	DWG NO.: 317-0000-2381
				DR: Sudong Li 12/8'14	SCALE SHEET REV. N/A 2/5 X2

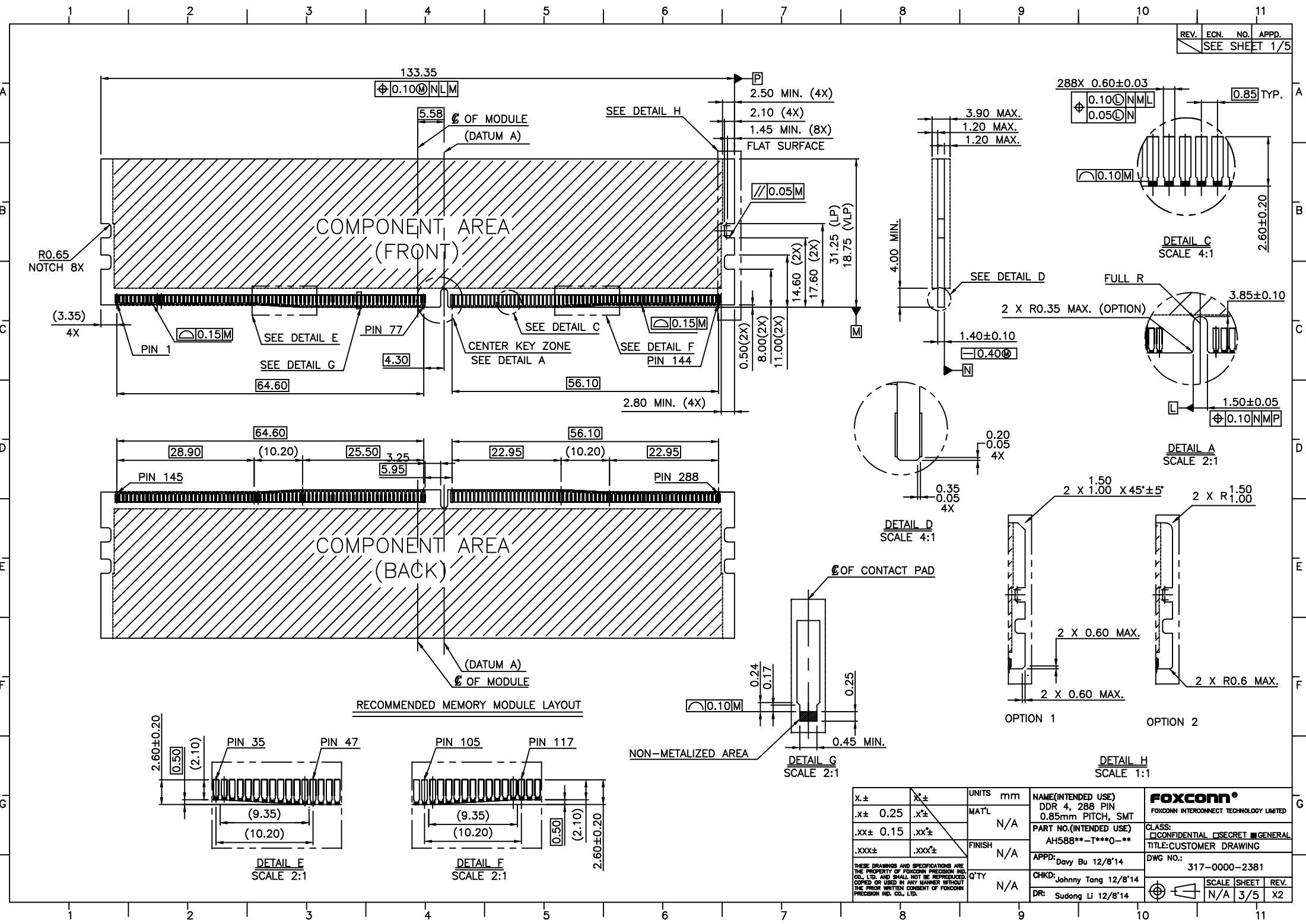

RECOMMENDED MEMORY MODULE LAYOUT

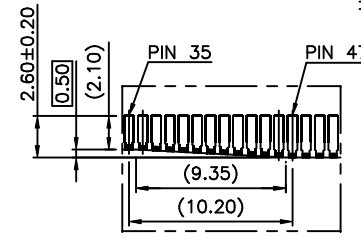

DETAIL E
SCALE 2:1

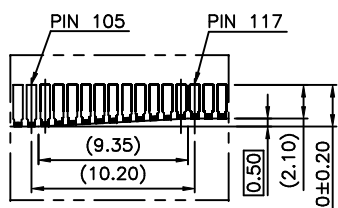

DETAIL F
SCALE 2:1

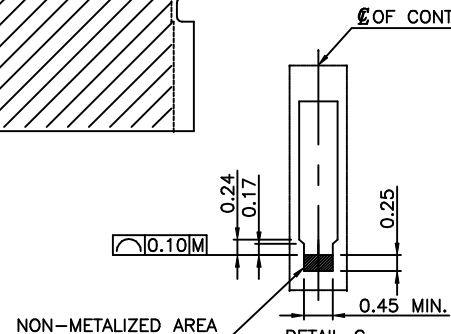

DETAIL G
SCALE 2:1

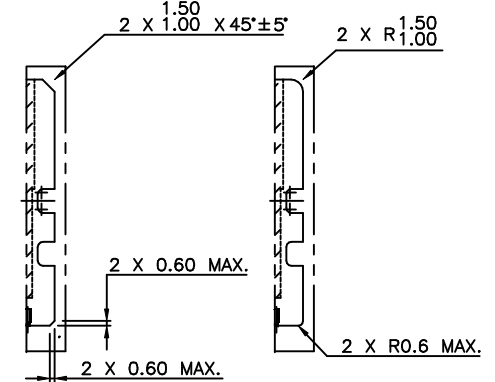

DETAIL H
SCALE 1:1

X.±	.X±	UNITS	mm
.XX±	.XX±	MAT'L	N/A
.XXX±	.XXX±	FINISH	N/A
		Q'TY	N/A

NAME(INTENDED USE)		APPD: Davy Bu 12/8'14
DDR 4, 288 PIN 0.85mm PITCH, SMT		
PART NO.(INTENDED USE)		CHKD: Johnny Tang 12/8'14
AH588**-T***0-**		
DR: Sudong Li 12/8'14		

FOXCONN® FOXCONN INTERCONNECT TECHNOLOGY LIMITED		
CLASS: <input type="checkbox"/> CONFIDENTIAL <input type="checkbox"/> SECRET <input type="checkbox"/> GENERAL		
TITLE: CUSTOMER DRAWING		
DWG NO.: 317-0000-2381		
SCALE	SHEET	REV.
N/A	3/5	X2

THESE DRAWINGS AND SPECIFICATIONS ARE THE PROPERTY OF FOXCONN PRECISION IND. CO., LTD. AND SHALL NOT BE REPRODUCED, COPIED OR USED IN ANY MANNER WITHOUT THE PRIOR WRITTEN CONSENT OF FOXCONN PRECISION IND. CO., LTD.

VIEW FOR PACKAGING TRAY

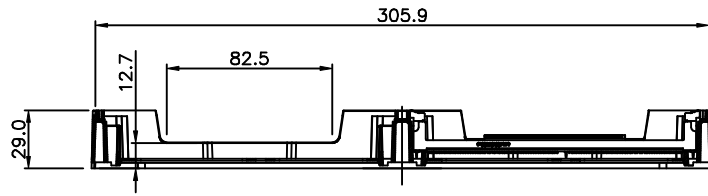
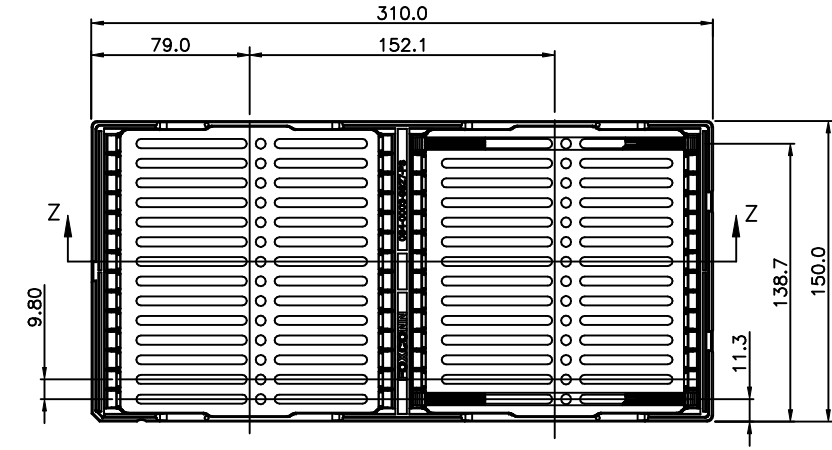

SECTION Z-Z

14 X 2 = 28 PCS / TRAY

X.±	X.±	UNITS	mm	NAME(INTENDED USE)	FOXCONN® FOXCONN INTERCONNECT TECHNOLOGY LIMITED			
.X± 0.25	.X±	MAT'L	N/A	DDR 4, 288 PIN 0.85mm PITCH, SMT				
.XX± 0.15	.XX±	FINISH	N/A	PART NO.(INTENDED USE)	CLASS: <input type="checkbox"/> CONFIDENTIAL <input type="checkbox"/> SECRET <input checked="" type="checkbox"/> GENERAL			
.XXX±	.XXX±	Q'TY	N/A	AH588**-T****-**	TITLE: CUSTOMER DRAWING			
THESE DRAWINGS AND SPECIFICATIONS ARE THE PROPERTY OF FOXCONN PRECISION IND. CO., LTD. AND SHALL NOT BE REPRODUCED, COPIED OR USED IN ANY MANNER WITHOUT THE PRIOR WRITTEN CONSENT OF FOXCONN PRECISION IND. CO., LTD.				APPD:	Davy Bu 12/8'14	DWG NO.:	317-0000-2381	
				CHKD:	Johnny Tang 12/8'14	SCALE	SHEET	REV.
				DR:	Sudong Li 12/8'14	N/A	4/5	X2

SPECIFICATION:

1. PHYSICAL:

- 1-1. HOUSING:
HIGH TEMPERATURE THERMOPLASTIC, UL 94V-0, COLOR: SEE PRODUCT NOMENCLATURE
- 1-2. CONTACT:
COPPER ALLOY, NICKEL PLATING THICKNESS 90 u" MIN. ON CONTACT AREA, 50 u" MIN. ON OTHER AREA.
TIN LEAD FREE PLATING, THICKNESS 100 u" MIN. AT TAILS, GOLD PLATING AT CONTACT AREA. THICKNESS REFER TO PRODUCT NOMENCLATURE.
- 1-3. EJECTOR:
THERMOPLASTIC, UL 94V-0, COLOR: SEE PRODUCT NOMENCLATURE
- 1-4. METAL BOARD LOCK: COPPER ALLOY.

2. ELECTRICAL CHARACTERISTICS:

- 2-1. CONTACT CURRENT RATING: 0.75 AMPS MAX.
- 2-2. INSULATION RESISTANCE: 1 MEGOHMS MIN. AT 500 VDC.
- 2-3. DIELECTRIC WITHSTANDING VOLTAGE: 500 VDC AT SEA LEVEL.
- 2-4. LOW LEVEL CONTACT RESISTANCE (DRY CIRCUIT):
INITIAL: 10 MILLIOHMS MAX.
FINAL: 20 MILLIOHMS MAX. AFTER FULL ENVIRONMENTAL TESTING.

3. MECHANICAL CHARACTERISTICS:

- 3-1. CONTACT RETENTION FORCE: 0.30 KG. (0.66 LBS) MIN. PER PIN.
- 3-2. DURABILITY: 25 CYCLES.
- 3-3. UNMATING FORCE (PER CONTACT PAIR): 14 g MIN.
- 3-4. INSERTION FORCE OF MODULE INTO CONNECTOR: 10.88 KG (24 LBS) MAX.
- 3-5. INSERTION FORCE OF CONNECTOR INTO PCB (WITH THREE BOARD LOCKS): 7.65 KG (17 LBS) MAX for TYPE A.
2.0 KG (4.4 LBS) MAX for TYPE B.

4. ENVIRONMENTAL CHARACTERISTICS:

- 4-1. SOLDERABILITY: PASSED PER EIA-364-52, CLASS 2, CATEGORY 3.
- 4-2. VIBRATION: PASSED PER EIA-364-28.
- 4-3. HUMIDITY: PASSED PER EIA-364-31.
- 4-4. THERMAL SHOCK: PASSED PER EIA-364-32.
- 4-5. OPERATING TEMPERATURE: 0°C TO 85°C.
- 4-6. MECHANICAL SHOCK: PASSED PER EIA-364-27.

PRODUCT NOMENCLATURE

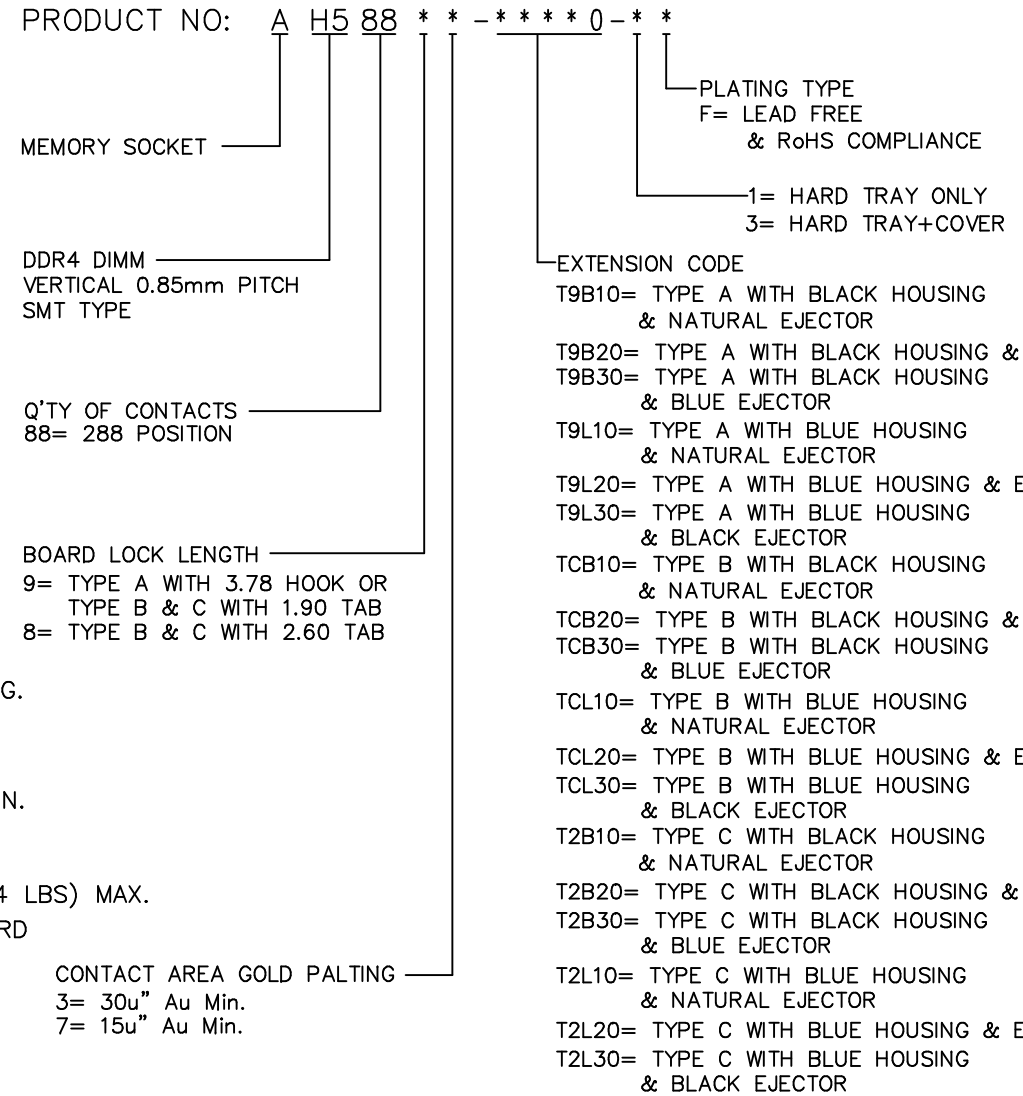

X.±	.X±	UNITS	mm	NAME(INTENDED USE)	FOXCONN® FOXCONN INTERCONNECT TECHNOLOGY LIMITED
.X± 0.25	.X±	MATL	N/A	DDR 4, 288 PIN 0.85mm PITCH, SMT	
.XX± 0.15	.XX±	FINISH	N/A	PART NO.(INTENDED USE)	CLASS: <input type="checkbox"/> CONFIDENTIAL <input type="checkbox"/> SECRET <input checked="" type="checkbox"/> GENERAL
.XXX±	.XXX±	Q'TY	N/A	AH588**-T***0-***	TITLE: CUSTOMER DRAWING
THESE DRAWINGS AND SPECIFICATIONS ARE THE PROPERTY OF FOXCONN PRECISION IND. CO., LTD. AND SHALL NOT BE REPRODUCED, COPIED OR USED IN ANY MANNER WITHOUT THE PRIOR WRITTEN CONSENT OF FOXCONN PRECISION IND. CO., LTD.				APPD: Davy Bu 12/8'14	DWG NO.: 317-0000-2381
				CHKD: Johnny Tang 12/8'14	SCALE SHEET REV.
				DR: Sudong Li 12/8'14	N/A 5/5 X2