

### 1.View and size(视图及尺寸)

Main technical indicators(主要技术指标)	
1.Mating (插拔次数)	>100
2.Working Temperature (温度)	-40~+80 °C
3.IP Rating (防护级别)	IP 67
4.Diameter of socket end(插合端直径)	
5.Rated voltage (额定电压)	30V
6.Rated impulse voltage (额定冲击电压)	800V
7.Rated Current (额定电流)	1.5A
8.Sheathing material(外壳材料)	CuZn( 黄铜镀镍/ Brass nickel plated )
9.Contact material(触点材料)	CuZn( 黄铜/Brass )
10.Insulation(绝缘材料)	PA

Sum up(总结)	
Series(系列)	M8
Shell style/model (外壳样式/型号)	HGG:Fixed receptaCXe, nut fixing, watertight or vacuum-tight/固定插头, 螺母固定, 水密或真空密
Button (按键)	A button(一个按键)
Termination type (终止类型)	Mother solder tin(公焊锡)
Line diameter awg(线材直径)	26AWG-24AWG
Cable diameter φ (电缆直径)	6-8mm
Match plug(匹配插座)	

Location pin combination (定位销组合)		
(编号) Numder	Number of positioning pins(定位销数量)	结构图形
A	1	
B	1	
D	2	

	A	B	C√	ANGLE	
5-10	±0.02	±0.05	±0.1	0°-30°	±0.1°
50-100	±0.1	±0.15	±0.2	61°-90°	±0.5°
50-100	±0.15	±0.2	±0.25		
100-	±0.15%	±0.20%	±0.25%		

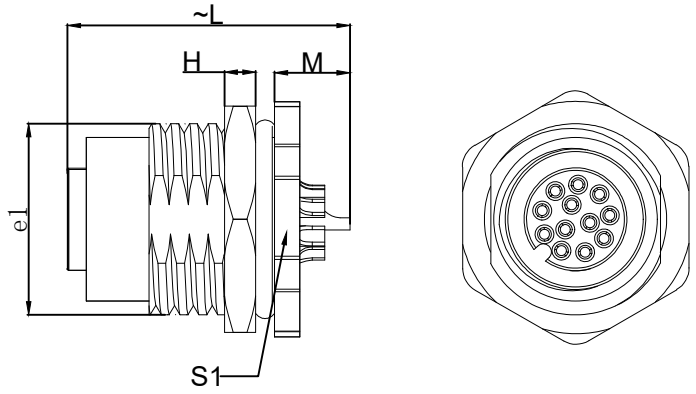

	L	S1	H	M	e1
MM	22.5	18	2.5	6	M16*1.5
in	0.8858	0.7087	0.0984	0.2362	

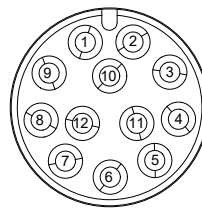

Welded surface (焊接面)

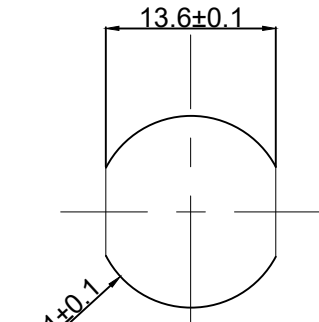

Pane hole size (面板开孔尺寸)

ZG A.M12.P12.N P L

Appearance(外观)

Positioning pin(定位销)

Series(系列)

Needle core configuration(针芯配置)

Outer casing(外壳)

Insulator(绝缘体)

Needle core(针芯)

DESIGNED(设计)		DATE(日期)		SCALE(比例)	N/A(不适用)	MODEL TYPE 型号类型: ZGA.M12.P12.NPL
CHECKED(校对)		DATE(日期)		VIEW(视图)		PART NO. 1B2 core socket
APPROVED(审核)		DATE(日期)		UNIT(单位)	MM	名称: M12A定位12芯母座
REVISIONS				MATERIAL (材料)		DWG NO.:
www.helloxkb.com www.helloxkb.cn			XKB INDUSTRIAL PRECISION CO.,LIMITED			WEIGHT(重量) SHEET(表) REVISION(修订)
						1/1 A0