

1. DESCRIPTION

The XL78L05 Series of positive voltage regulators are inexpensive, easy-to-use devices suitable for a multitude of applications that require a regulated supply of up to 100 mA. These regulators feature internal current limiting and thermal shutdown making them remarkably rugged. No external components are required with the XL78L05A/XT78L05 devices in many applications.

These devices offer a substantial performance advantage over the traditional zener diode-resistor combination, as output impedance and quiescent current are substantially reduced.

2. FEATURES

- Wide Range of Available, Fixed Output Voltages
- Internal Short Circuit Current Limiting
- Internal Thermal Overload Protection
- No External Components Required
- These are Pb-Free Devices
- Two packages: XL78L05A (SOP8), XT78L05 (TO92)

3. PIN CONFIGURATIONS

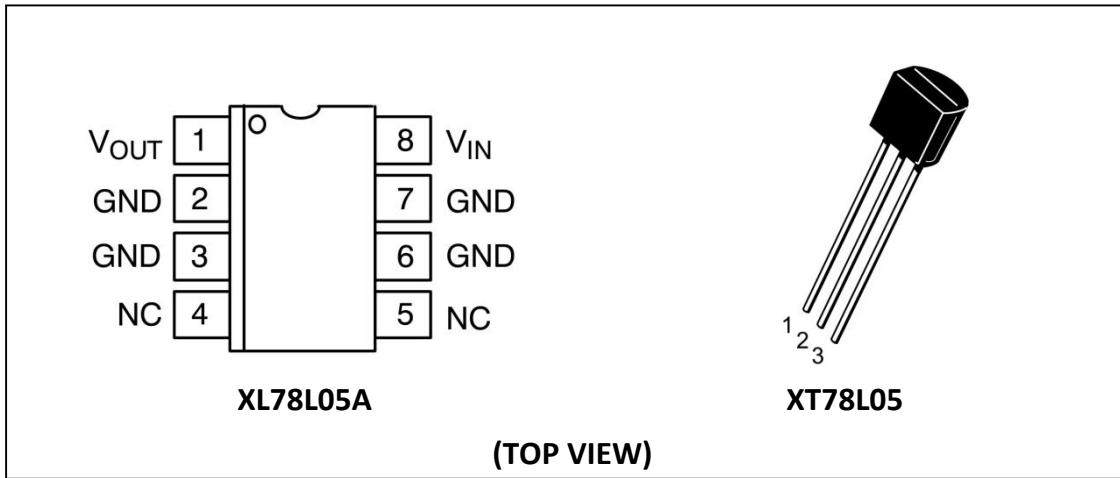

Pin Functions

Symbol	Pin		Description
	XL7805A (SOP8)	XT78L05 (TO92)	
VOUT	1	1	Output voltage pin
GND	2,3,6,7	2	Ground
NC	4, 5	-	No connection
V _{IN}	8	3	Input supply voltage pin

4. SCHEMATIC DIAGRAM

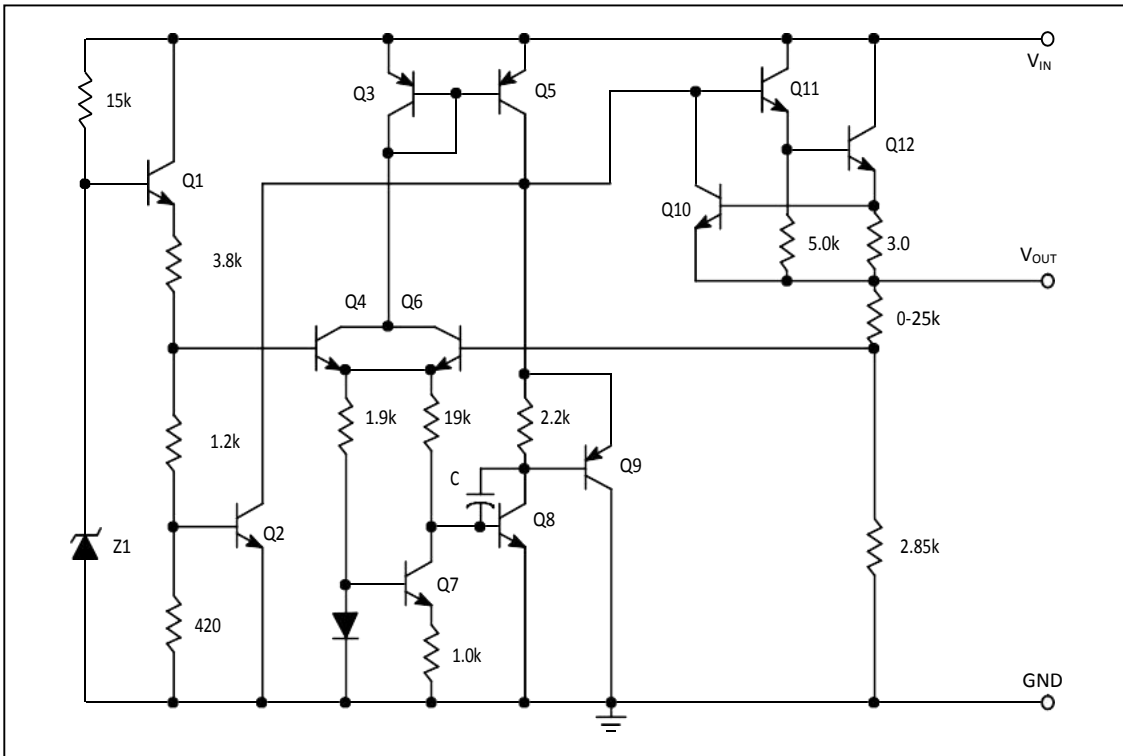

Figure 4-1. Representative Schematic Diagram

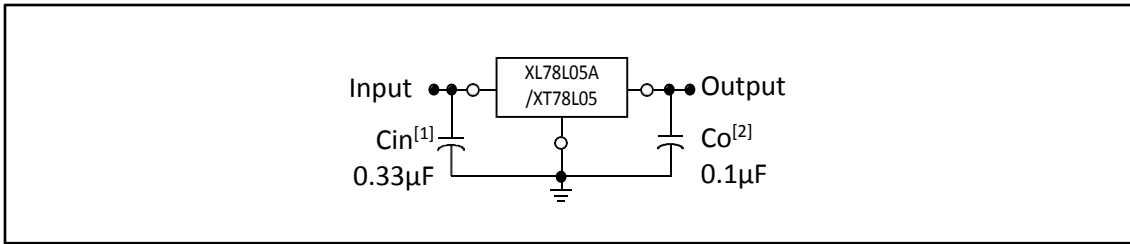

Figure 4-2. Standard Application

A common ground is required between the input and the output voltages. The input voltage must remain typically 2.0 V above the output voltage even during the low point on the input ripple voltage.

- [1] Cin is required if regulator is located an appreciable distance from power supply filter.
- [2] Co is not needed for stability; however, it does improve transient response

5. SPECIFICATIONS

5.1. Absolute Maximum Ratings

Rating	Symbol	Value	Unit
Input Voltage	V_I	30	Vdc
Storage Temperature Range	T_{stg}	-45 to +150	°C
Maximum Junction Temperature	T_J	125	°C
Moisture Sensitivity Level	MSL	1	-
ESD Capability, Human Body Model (Note 1)	ESDHBM	2000	V
ESD Capability, Machine Model (Note 1)	ESDMM	200	V
ESD Capability, Charged Device Model (Note 1)	ESDCDM	2000	V

Stresses exceeding Maximum Ratings may damage the device. Maximum Ratings are stress ratings only. Functional operation above the Recommended Operating Conditions is not implied. Extended exposure to stresses above the Recommended Operating Conditions may affect device reliability.

- [1] This device series incorporates ESD protection and is tested by the following methods:
 ESD Human Body Model tested per AEC-Q100-002 (EIA/JESD22-A114)
 ESD Machine Model tested per AEC-Q100-003 (EIA/JESD22-A115)
 ESD Charged Device Model tested per EIA/JES D22/C101, Field Induced Charge Model.

5.2. Thermal Resistance Characteristics

Rating	Symbol	Value	Unit
Package Dissipation	PD	Internally Limited	W
Thermal Characteristics, TO92 Thermal Resistance, Junction-to-Ambient	$R_{\theta JA}$	200	°C/W
Thermal Characteristics, SOP8 Thermal Resistance, Junction-to-Ambient	$R_{\theta JA}$	Refer to Figure 8	°C/W

- [2] Thermal Resistance, Junction-to-Ambient depends on P.C.B. Copper area. See details in Figure 8.

Thermal Resistance, Junction-to-Case is not defined. SOP 8 lead and TO92 packages that do not have a heat sink like other packages may have. This is the reason that a Theta JC is never specified. A little heat transfer will occur through the package but since it is plastic, it is minimal. The majority of the heat that is transferred is through the leads where they connect to the circuit board.

5.3. Electrical Characteristics

($V_I = 10\text{ V}$, $I_O = 40\text{ mA}$, $C_I = 0.33\text{ }\mu\text{F}$, $C_O = 0.1\text{ }\mu\text{F}$, $-40^\circ\text{C} < T_J < +85^\circ\text{C}$, unless otherwise noted.)

Characteristics	Symbol	XL78L05A, XT78L05			Unit
		Min	Typ	Max	
Output Voltage ($T_J = +25^\circ\text{C}$)	V_O	4.8	5.0	5.2	Vdc
Line Regulation ($T_J = +25^\circ\text{C}$, $I_O = 40\text{ mA}$) $7.0\text{ Vdc} \leq V_I \leq 20\text{ Vdc}$ $8.0\text{ Vdc} \leq V_I \leq 20\text{ Vdc}$	Regline	– –	55 45	150 100	mV
Load Regulation ($T_J = +25^\circ\text{C}$, $1.0\text{ mA} \leq I_O \leq 100\text{ mA}$) ($T_J = +25^\circ\text{C}$, $1.0\text{ mA} \leq I_O \leq 40\text{ mA}$)	Regload	– –	11 5.0	60 30	mV
Output Voltage ($7.0\text{ Vdc} \leq V_I \leq 20\text{ Vdc}$, $1.0\text{ mA} \leq I_O \leq 40\text{ mA}$) ($V_I = 10\text{ V}$, $1.0\text{ mA} \leq I_O \leq 70\text{ mA}$)	V_O	4.75 4.75	– –	5.25 5.25	Vdc
Input Bias Current ($T_J = +25^\circ\text{C}$) ($T_J = +85^\circ\text{C}$)	I_{IB}	– –	3.8 –	6.0 5.5	mA
Input Bias Current Change ($8.0\text{ Vdc} \leq V_I \leq 20\text{ Vdc}$) ($1.0\text{ mA} \leq I_O \leq 40\text{ mA}$)	ΔI_{IB}	– –	– –	1.5 0.1	mA
Output Noise Voltage ($T_A = +25^\circ\text{C}$, $10\text{ Hz} \leq f \leq 100\text{ kHz}$)	V_n	–	40	–	μV
Ripple Rejection ($I_O = 40\text{ mA}$, $f = 120\text{ Hz}$, $8.0\text{ Vdc} \leq V_I \leq 18\text{ V}$, $T_J = +25^\circ\text{C}$)	RR	41	49	–	dB
Dropout Voltage ($T_J = +25^\circ\text{C}$)	$V_I - V_O$	–	1.7	–	Vdc

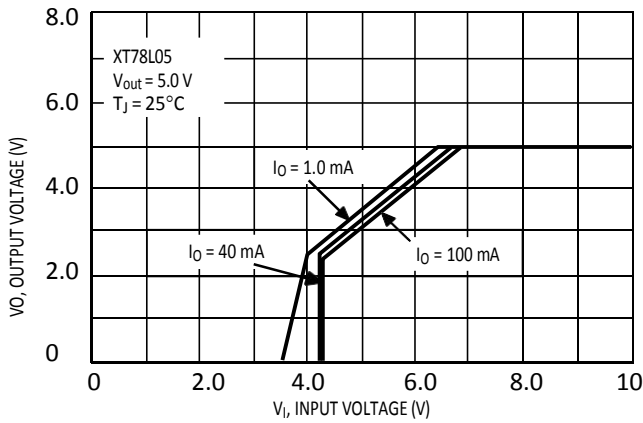

Figure 5-1. Dropout Characteristics

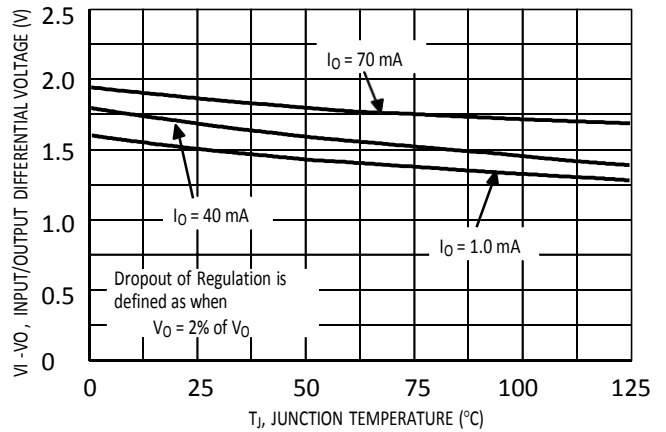

Figure 5-2. Dropout Voltage versus Junction Temperature

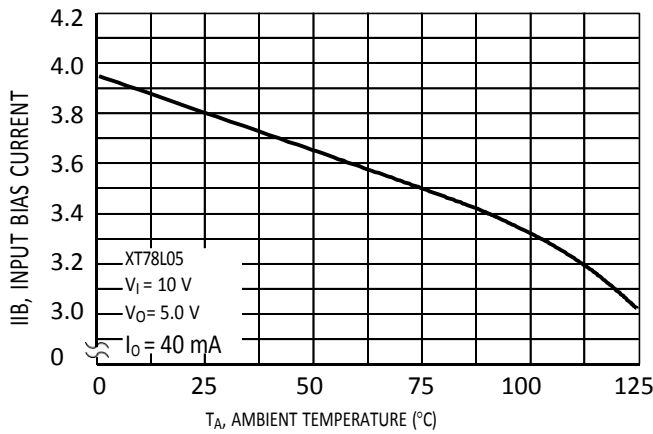

Figure 5-3. Input Bias Current versus Ambient Temperature

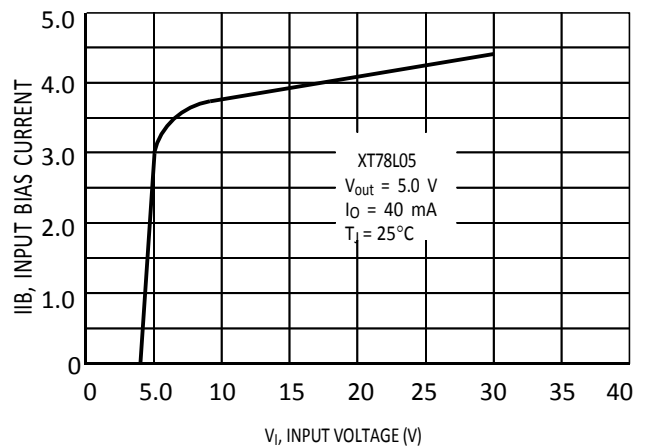

Figure 5-4. Input Bias Current versus Input Voltage

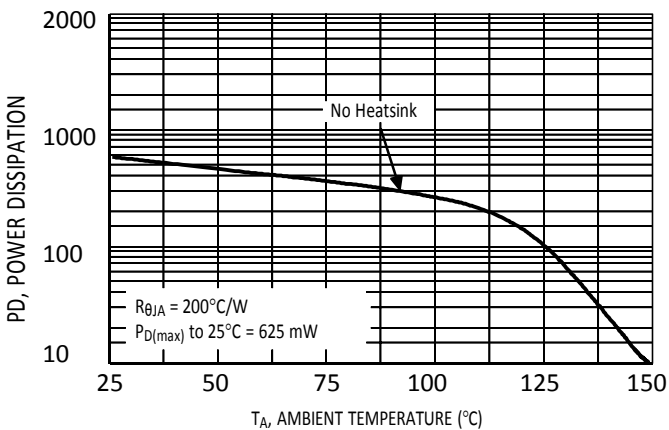

Figure 5-5. Maximum Average Power Dissipation versus Ambient Temperature – TO92 Type Package

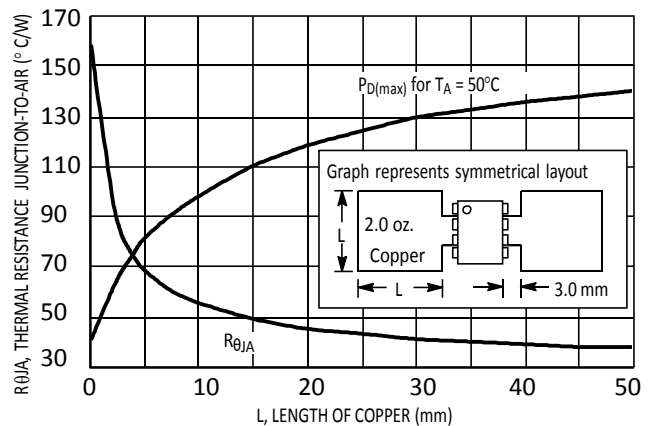

Figure 5-6. SOP8 Thermal Resistance and Maximum Power Dissipation versus P.C.B. Copper Length

6. APPLICATIONS INFORMATION

6.1. Design Considerations

The XL78L05 Series of fixed voltage regulators are designed with Thermal Overload Protection that shuts down the circuit when subjected to an excessive power overload condition. Internal Short Circuit Protection limits the maximum current the circuit will pass.

In many low current applications, compensation capacitors are not required. However, it is recommended that the regulator input be bypassed with a capacitor if the regulator is connected to the power supply filter with long wire lengths, or if the output load capacitance is large. The input bypass capacitor should be selected to provide good high-frequency characteristics to insure stable operation under all load conditions. A 0.33 μF or larger tantalum, mylar, or other capacitor having low internal impedance at high frequencies should be chosen. The bypass capacitor should be mounted with the shortest possible leads directly across the regulators input terminals. Good construction techniques should be used to minimize ground loops and lead resistance drops since the regulator has no external sense lead. Bypassing the output is also recommended.

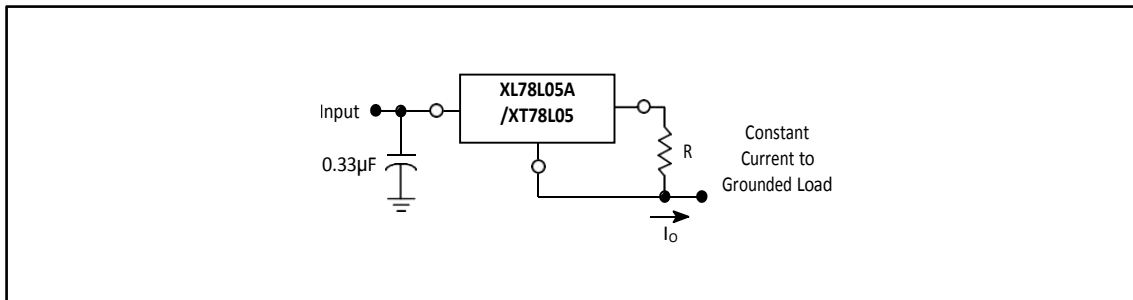

Figure 6-1. Current Regulator

The XL78L05A/XT78L05 regulators can also be used as a current source when connected as above. Resistor R determines the current as follows:

$$I_O = \frac{5.0}{R} + I_B$$

$$I_B = 3.8 \text{ mA over line and load changes}$$

For example, a 100 mA current source would require R to be a 50 Ω , 1/2 W resistor and the output voltage compliance would be the input voltage less 7 V.

7. ORDERING INFORMATION

Part Number	Device Marking	Package Type	Body size (mm)	Temperature (°C)	MSL	Transport Media	Package Quantity
XL78L05A	XL78L05A	SOP8	4.90 * 3.90	-40 to +85	MSL3	T&R	2500
XT78L05	XT78L05	TO92	4.58 * 4.58	-40 to +85	MSL3	T&R	1000

8. DIMENSIONAL DRAWINGS

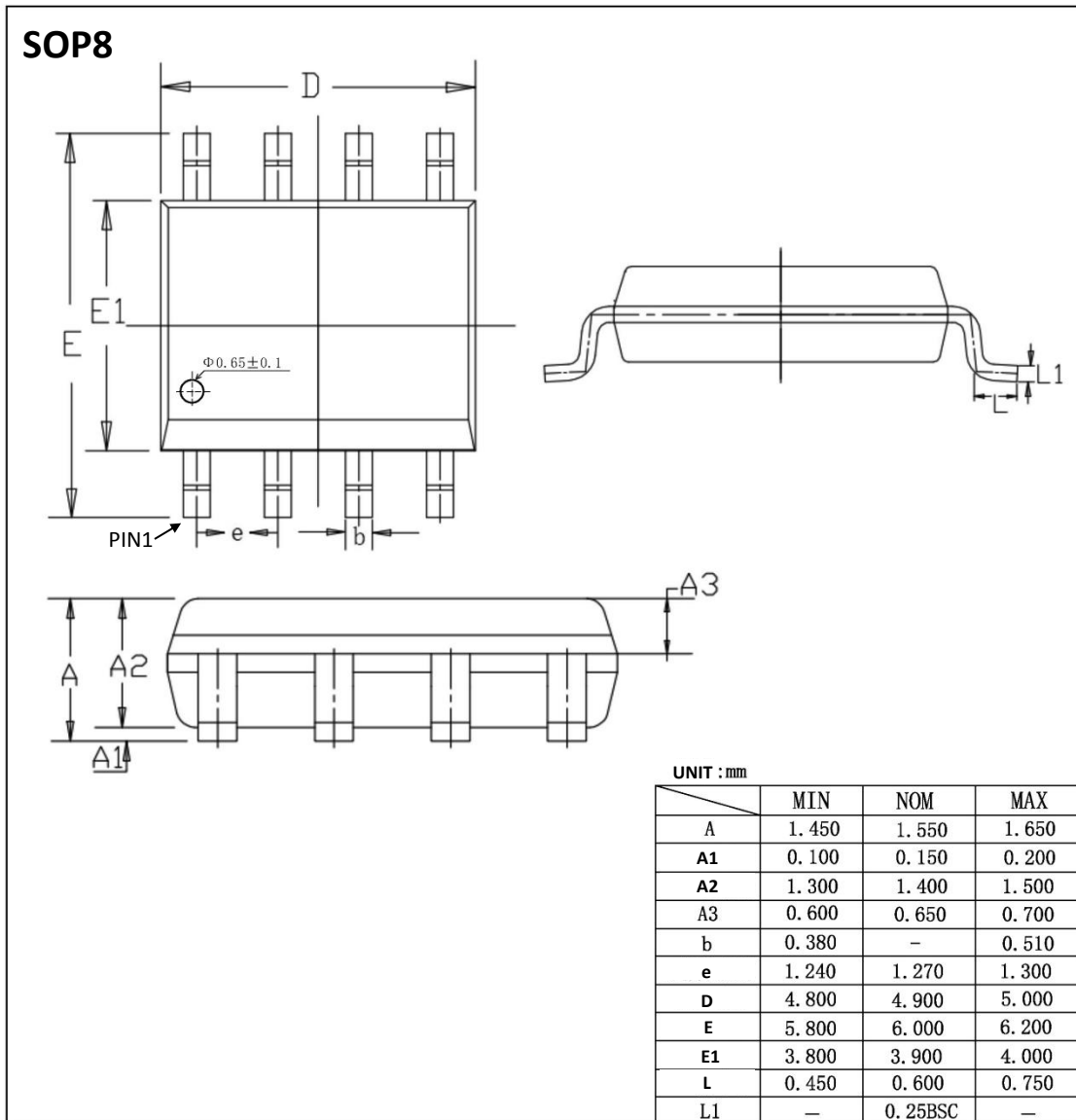

T092

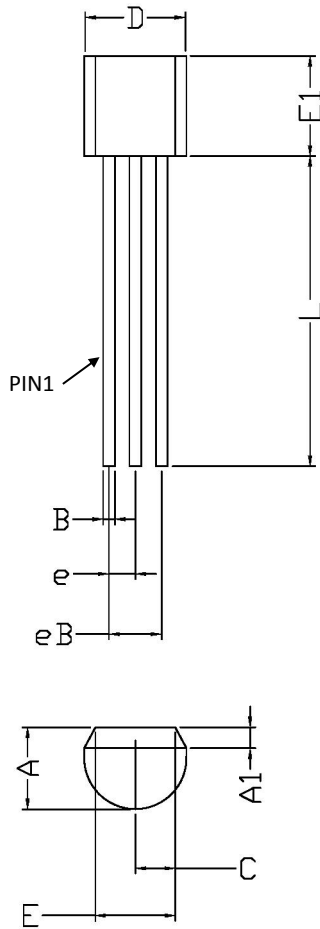

SYMBOL	MIN	MAX
A	3.46	3.96
A1	1.02 TYP	
B	0.36	0.56
C	1.80 TYP	
D	4.33	4.83
E1	4.33	4.83
E	3.35	3.85
eB	2.54 TYP	
e	1.27 TYP	
L	13.97	14.97

UNIT : mm