

# DIA2602

## High Voltage, Rail-to-Rail Output Operational Amplifiers

### Description

The DIA2602 (dual) is an amplifier with very low noise, high voltage, and low power. The DIA2602 has a high gain-bandwidth product of 3.5 MHz, a slew rate of 2.5 V/ $\mu$ s, and a quiescent current of 0.75 mA per amplifier at 4.5 V typically.

The DIA2602 is designed to provide optimal performance in low voltage and low noise systems. All these chips provide rail-to-rail output swing into heavy loads. The input common-mode voltage ranges from -0.1 to  $(+V_S - 1.5)$  V, and the maximum input offset voltage is 3.5 mV for the DIA2602.

It is specified over the extended industrial temperature range  $-40^{\circ}\text{C}$  to  $125^{\circ}\text{C}$ . The operating range is from 4.5 V to 36 V.

### Features

- AEC-Q100 qualified
- Device temperature grade 1:  $-40^{\circ}\text{C}$  ~  $125^{\circ}\text{C}$
- HBM ESD at  $\pm 2000$  V
- CDM ESD at  $\pm 500$  V
- Supply voltage range: 4.5 V ~ 36 V
- Low supply current:
  - 0.95 mA per channel at  $V_S = 36$  V
  - 0.75 mA per channel at  $V_S = 4.5$  V
- Input voltage range:  $-0.1$  V ~  $(+V_S - 1.5)$  V
- Low offset voltage: 3.5 mV (max)
- Rail-to-rail output:  $-V_S$  ~  $+V_S$
- 3.5 MHz high gain-bandwidth product
- High slew rate: 2.5 V/ $\mu$ s
- Settling time to 0.1% with 2 V step: 0.9  $\mu$ s
- Package: SOIC-8

### Applications

- Automotive lighting
- Body electronics
- Automotive head unit
- Telematics control unit
- Emergency call (eCall)
- Passive safety: brake system

## ■ Ordering Information

Part Number	Top Marking	RoHS	T <sub>A</sub>	Package	
DIA2602SO8	DIA62AH	Green	-40 to 125°C	SOIC-8	Tape & Reel, 2500

If you encounter any issue in the process of using the device, please contact our customer service at [marketing@dioo.com](mailto:marketing@dioo.com) or phone us at (+86)-21-62116882. If you have any improvement suggestions regarding the datasheet, we encourage you to contact our technical writing team at [docs@dioo.com](mailto:docs@dioo.com). Your feedback is invaluable for us to provide a better user experience.

## Table of Contents

1. Pin Assignment and Functions .....	1
2. Absolute Maximum Ratings .....	1
3. Recommended Operating Condition .....	2
4. ESD Ratings .....	2
5. Electrical Characteristics .....	3
6. Application Information .....	4
7. Physical Dimensions: SOIC-8 .....	7

## List of Figures

Figure 1 . Quiescent current vs. Supply voltage .....	4
Figure 2 . Quiescent current vs. Temperature .....	4
Figure 3 . $V_{OS}$ vs. Temperature .....	4
Figure 4 . $V_{OC}$ vs. $V_{CC}$ .....	4
Figure 5 . Positive overload recovery .....	4
Figure 6 . Negative overload recovery .....	4
Figure 7 . Signal step response .....	5
Figure 8 . Signal step response .....	5
Figure 9 . Small-signal response .....	5
Figure 10 . THD+N vs. Frequency .....	5
Figure 11 . Voltage noise spectral density vs. Frequency .....	5
Figure 12 . Indirectly driving heavy capacitive load .....	6
Figure 13 . Indirectly driving heavy capacitive load with DC accuracy .....	6
Figure 14 . Amplifier with bypass capacitors .....	6



## 1. Pin Assignment and Functions

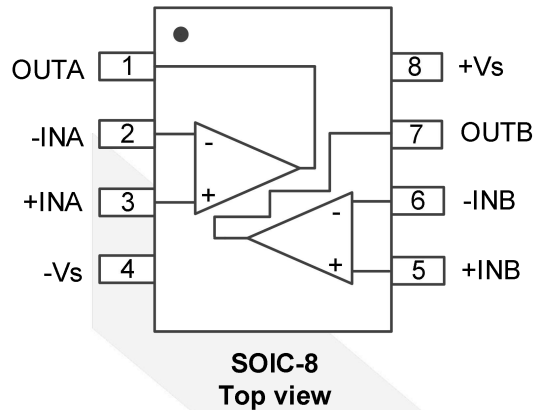

Pin No.	Pin name	Description
8	+Vs	Positive supply
4	-Vs	Negative supply
3, 5	+IN (+INA/+INB)	Positive input (channel A/B)
2, 6	-IN (-INA/-INB)	Negative input (channel A/B)
1, 7	OUT (OUTA/OUTB)	Output (channel A/B)

## 2. Absolute Maximum Ratings

Exceeding the maximum ratings listed under Absolute Maximum Ratings when designing is likely to damage the device permanently. Do not design to the maximum limits because long-time exposure to them might impact the device's reliability. The ratings are obtained over an operating free-air temperature range unless otherwise specified.

Symbol	Parameter	Rating	Unit
$V_S$	Supply voltage	40	V
$V_{IN}$	Input voltage	$(-V_S - 0.3)$ to $(+V_S + 0.3)$	V
$T_{STG}$	Storage temperature range	-65 to 150	°C
$T_J$	Junction temperature	150	°C
$T_L$	Lead temperature range	260	°C

### 3. Recommended Operating Condition

Recommended operating conditions are specified to ensure optimal performance to the datasheet specifications. The ratings are obtained over an operating free-air temperature range unless otherwise specified.

Symbol	Parameter	Rating	Unit
$V_S$	Supply voltage	4.5 to 36	V
$V_{IN}$	Input voltage	-0.1 to ( $+V_S - 1.5$ V)	V
$T_A$	Operating temperature range	-40 to 125	°C

### 4. ESD Ratings

When a statically-charged person or object touches an electrostatic discharge sensitive device, the electrostatic charge might be drained through sensitive circuitry in the device. If the electrostatic discharge possesses sufficient energy, damage might occur to the device due to localized overheating.

Model	Condition	Value	Unit
HBM	AEC Q100-002	±2000	V
CDM	AEC Q100-011	±500	V

## 5. Electrical Characteristics

Typical value:  $T_A = 25^\circ\text{C}$ ,  $+V_S = 30\text{ V}$ ,  $-V_S = 0\text{ V}$ ,  $R_L = 10\text{ k}\Omega$ , unless otherwise specified.

Symbol	Parameter	Conditions	Min	Typ	Max	Unit
--------	-----------	------------	-----	-----	-----	------

### Power supply

$V_S$	Supply voltage range		4.5		36	V
PSRR	Power supply rejection ratio			120		dB
$I_Q$	Supply current per channel/amplifier	$V_S = 4.5\text{ V}$		0.75		mA
		$V_S = 36\text{ V}$		0.95		mA

### Input characteristics

$V_{OS}$	Input offset voltage	$V_{CM} = +V_S/2$ , $T_A = 25^\circ\text{C}$	-3.5		3.5	mV
$V_{CM}$	Common mode voltage range		-0.1		$+V_S - 1.5$	V
CMRR	Common mode rejection ratio	$-40^\circ\text{C} \leq T_A \leq 125^\circ\text{C}$ , $+V_S = 36\text{ V}$ , $V_{CM} = 0.5\text{ V to } 28\text{ V}$		90		dB
$A_{OL}^{(1)}$	Open loop voltage gain			155		dB
$V_O$	Output swing high from supply rail	$R_L = 50\text{ k}\Omega$ , rising		20		mV
	Output swing low from supply rail	$R_L = 50\text{ k}\Omega$ , falling		15		mV
$\Delta V_{OS}/\Delta T$	Input offset voltage drift	$-40^\circ\text{C} \leq T_A \leq 125^\circ\text{C}$		5		$\mu\text{V}/^\circ\text{C}$

### Output characteristics

$I_{SC}$	Output short-circuit current	Sink current		14		mA
		Source current		14		mA

### Dynamic performance

GBP	Gain bandwidth product	$f = 1\text{ kHz}$		3.5		MHz
SR	Slew rate	$A_V = 1$ , 10 V step		2.5		$\text{V}/\mu\text{s}$
$t_S$	Settling time	$A_V = -1$ , 2 V step, 0.1%		0.9		$\mu\text{s}$
		$A_V = -1$ , 2 V step, 0.01%		1.2		$\mu\text{s}$
$t_{OR}$	Positive overload recovery time			1.4		$\mu\text{s}$
	Negative overload recovery time			1		$\mu\text{s}$

### Noise performance

THD+N	Total harmonic distortion and noise	$f = 1\text{ kHz}$ , $A_V = 1\text{ V}$ , $R_L = 2\text{ k}\Omega$ , $V_{OUT} = 3.5\text{ V}_{RMS}$		0.0005		%
$e_n$	Input voltage noise density	$f = 1\text{ kHz}$		32		$\text{nV}/\sqrt{\text{Hz}}$
$V_n$	Input voltage noise	$f = 0.1\text{ Hz to } 10\text{ Hz}$		2.35		$\mu\text{V}_{RMS}$
$X_{talk}$	Channel separation	$f = 1\text{ kHz}$ , $R_L = 1\text{ k}\Omega$		-100		dB

### Note:

- (1) Guaranteed by design.
- (2) Specifications subject to change without notice.

## 6. Typical Performance Characteristics

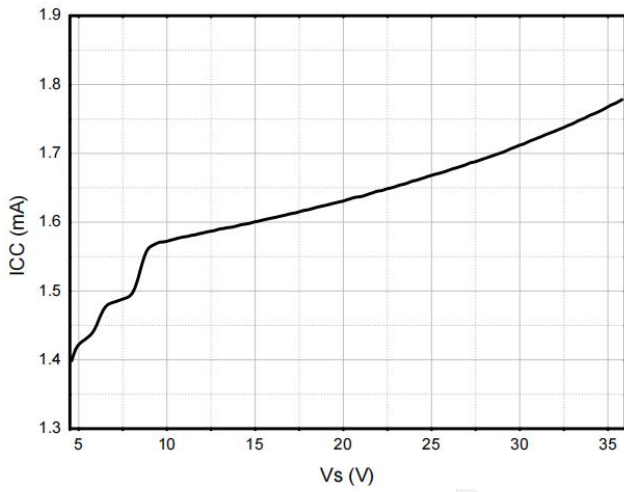

Figure 1. Quiescent current vs. Supply voltage

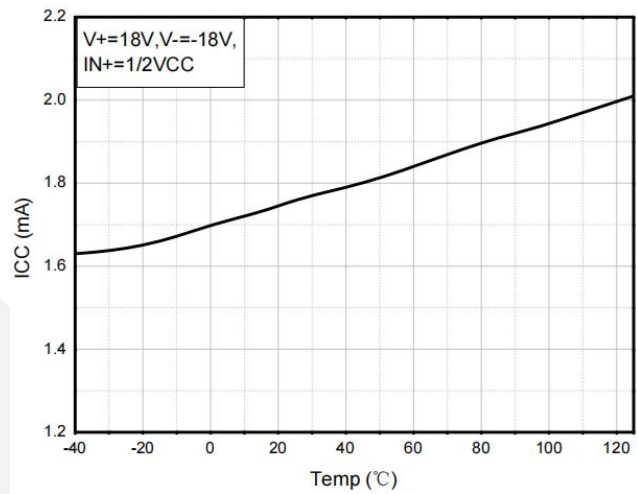

Figure 2. Quiescent current vs. Temperature

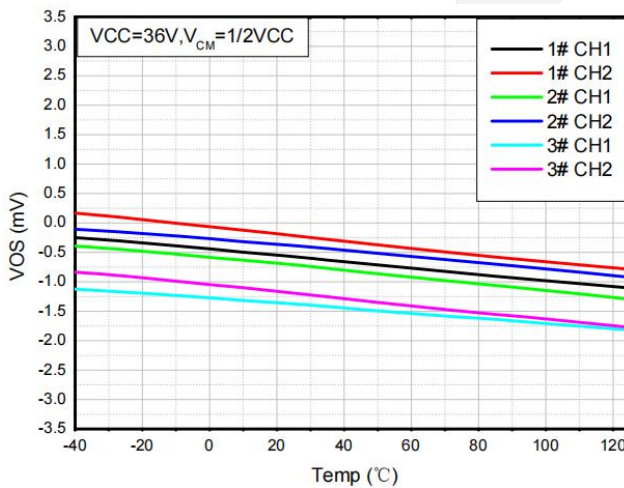

Figure 3. VOS vs. Temperature

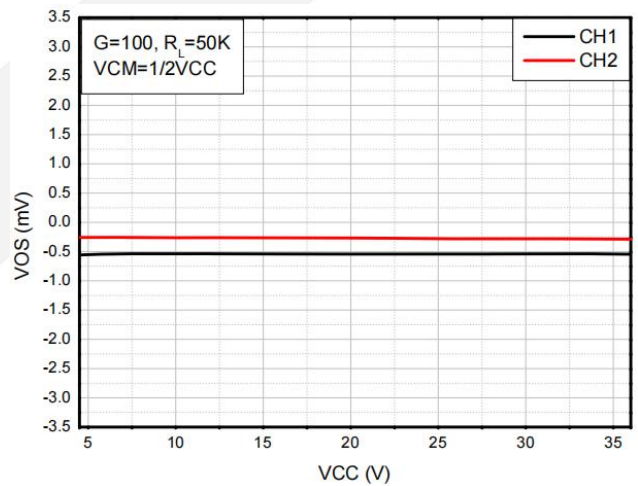
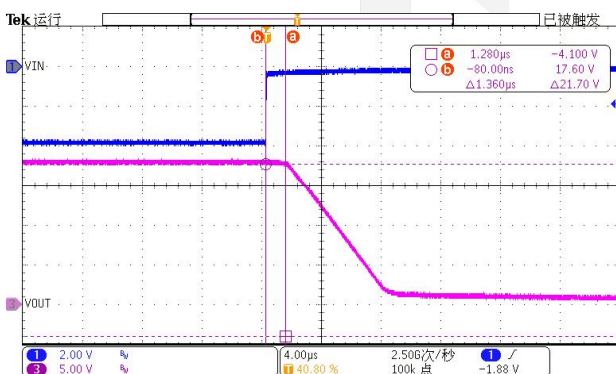
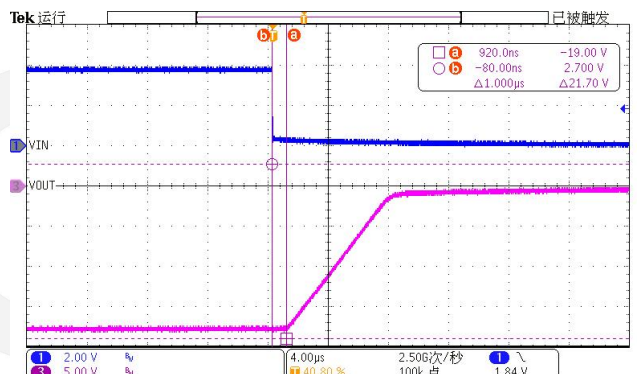

Figure 4.  $V_{oc}$  vs.  $V_{cc}$



$+V_S = 18\text{ V}$ ,  $V_- = -18\text{ V}$ ,  $G = 10$ ,  $R_L = 2\text{ k}\Omega$ ,  $C_L = 100\text{ pF}$ ,  
 $V_{IN} = 3.8\text{ Vpp}$  at  $1.9\text{ V}$

Figure 5. Positive overload recovery



$+V_S = 18\text{ V}$ ,  $V_- = -18\text{ V}$ ,  $G = 10$ ,  $R_L = 2\text{ k}\Omega$ ,  $C_L = 100\text{ pF}$ ,  
 $V_{IN} = 3.8\text{ Vpp}$  at  $-1.9\text{ V}$

Figure 6. Negative overload recovery

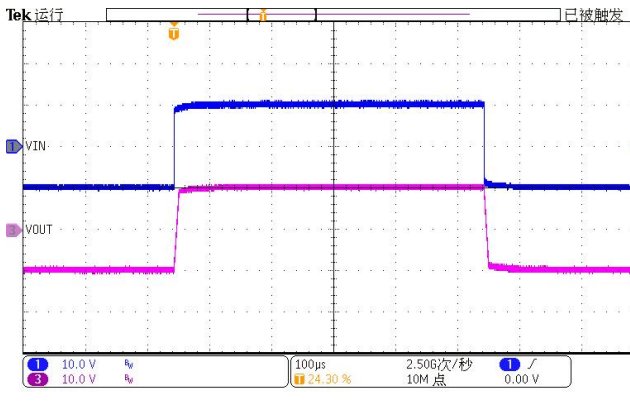

$+V_S = 18\text{ V}, -V_S = -18\text{ V}, G = 1, R_L = 2\text{ k}\Omega, C_L = 100\text{ pF}$   
 $V_{IN} = 10\text{ Vpp}$  at 1 kHz, 0 V bias

**Figure 7. Signal step response**

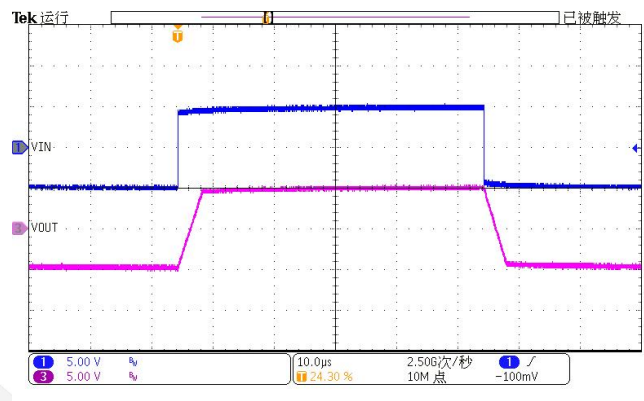

$+V_S = 18\text{ V}, -V_S = -18\text{ V}, G = 1, R_L = 2\text{ k}\Omega, C_L = 100\text{ pF}$   
 $V_{IN} = 10\text{ Vpp}$  at 10 kHz, 0 V bias

**Figure 8. Signal step response**

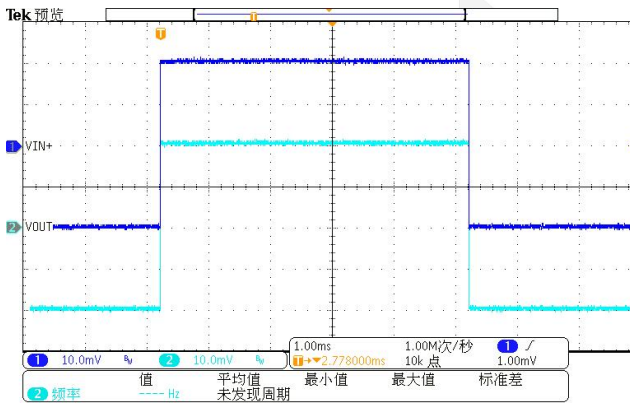

$+V_S = 18\text{ V}, -V_S = -18\text{ V}, G = 1, C_L = 100\text{ pF}, R_L = 2\text{ k}\Omega$  to GND,  
 40 mVpp at 0 V bias, 100 Hz

**Figure 9. Small-signal response**

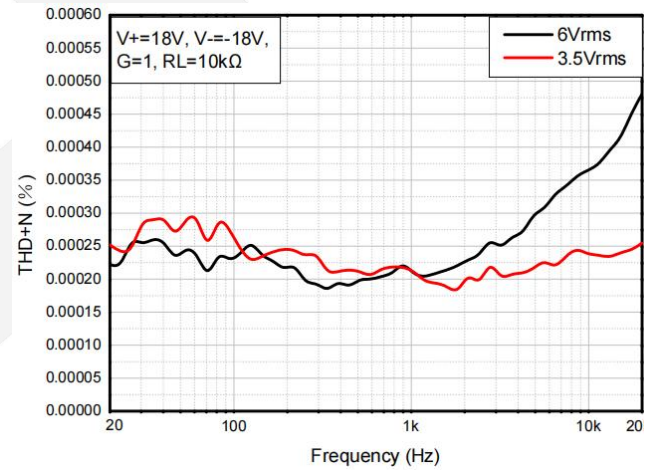

**Figure 10. THD+N vs. Frequency**

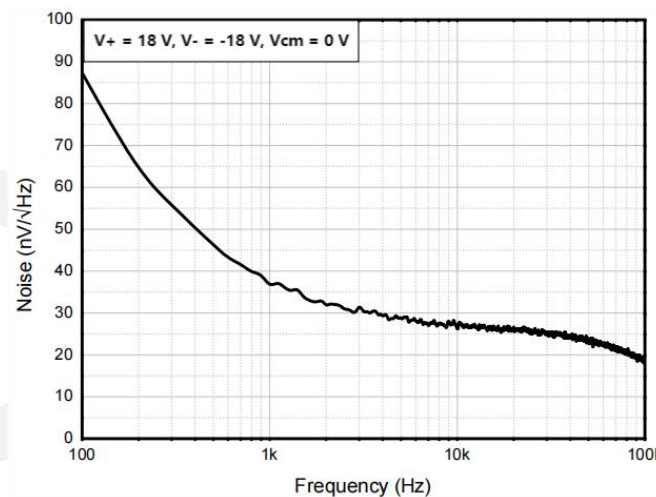

**Figure 11. Voltage noise spectral density vs. Frequency**



## 7. Application Information

**Important notice:** Validation and testing are the most reliable ways to confirm system functionality. The application information is not part of the specification and is for reference purposes only.

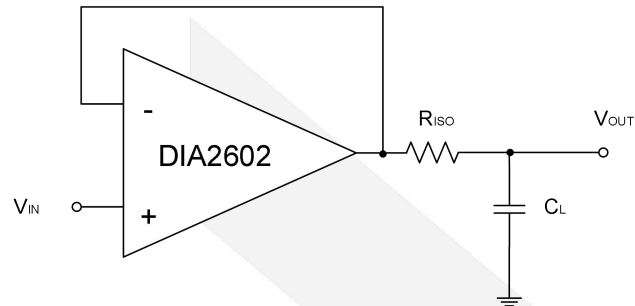

Figure 12. Indirectly driving heavy capacitive load

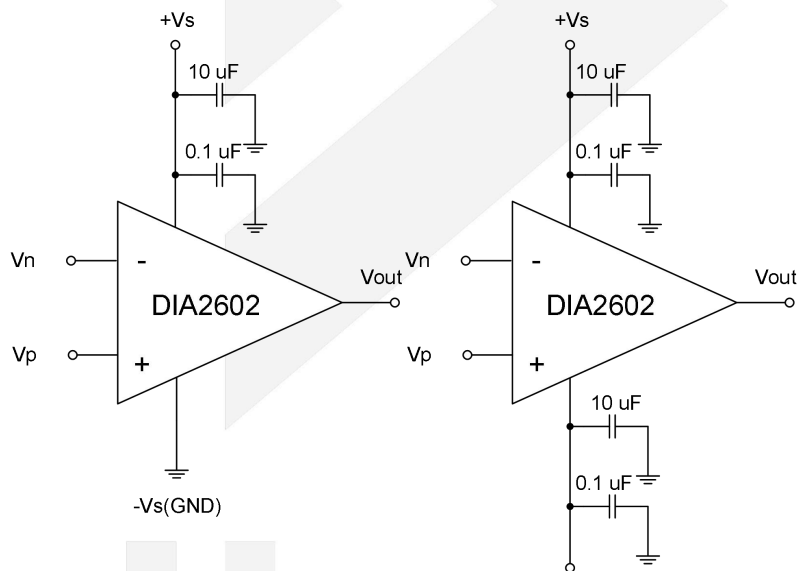

Figure 13. Indirectly driving heavy capacitive load with DC accuracy

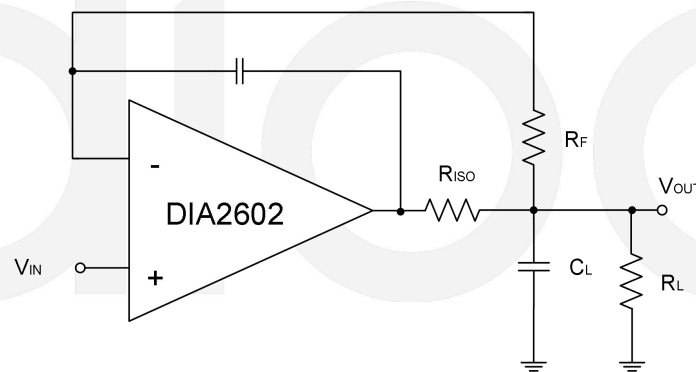
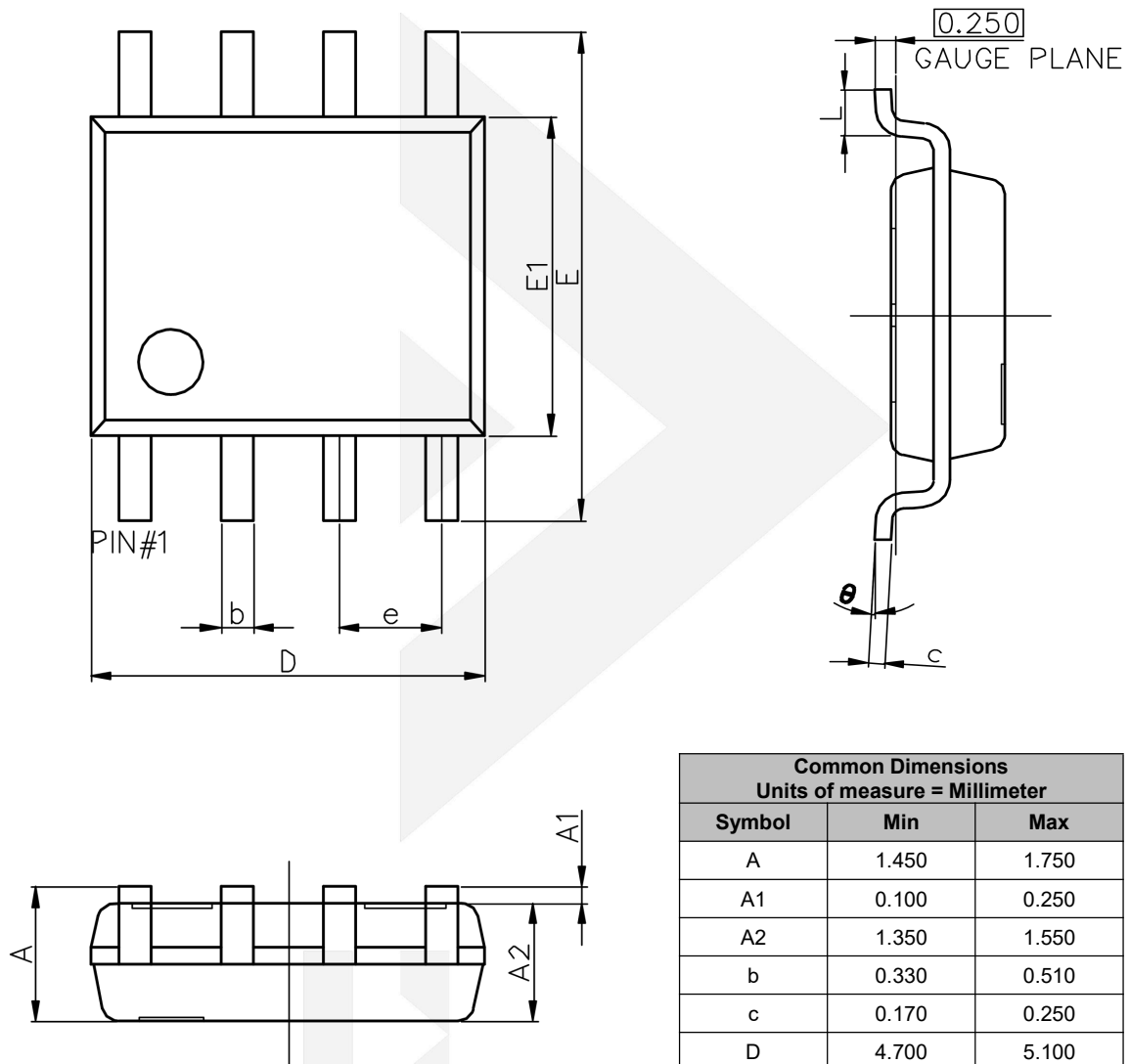

Figure 14. Amplifier with bypass capacitors

## 8. Physical Dimensions: SOIC-8



Common Dimensions		
Units of measure = Millimeter		
Symbol	Min	Max
A	1.450	1.750
A1	0.100	0.250
A2	1.350	1.550
b	0.330	0.510
c	0.170	0.250
D	4.700	5.100
E	5.800	6.200
E1	3.800	4.000
e	1.270 BSC	
L	0.400	1.270
$\theta$	0°	8°

## Disclaimer

This specification and information contained herein are provided on an “AS IS” basis and WITH ALL FAULTS. All product specifications, statements, information, and data (collectively, the “Information”) in this datasheet or made available on the website of [www.diao.com](http://www.diao.com) are subject to change without notice. The customer is responsible for checking and verifying the extent to which the Information contained in this publication is applicable to his/her application. All Information given herein is believed to be accurate and reliable, but it is presented without guarantee, warranty, or responsibility of any kind, express or implied.

