

DATA SHEET

BAT54WT-BAT54SWT

- ◇Epoxy meets UL 94 V-0 flammability rating
- ◇Small Outline Surface Mount Package
- ◇Low Current Leakage
- ◇For high-speed switching applications

Device	Device Marking	Type	Pin Configuration See page 2
BAT54WT	KL5	Single	Figure1
BAT54AWT	KL6	Dual	Figure2
BAT54CWT	KL7	Dual	Figure3
BAT54SWT	KL8	Dual	Figure4

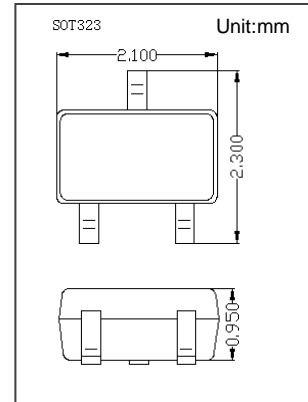

MAXIMUM RATINGS (Ta = 25 °C)

Symbol	Parameter	Value	Units
V_{RRM}	Peak Repetitive Reverse Voltage	30	V
V_{RWM}	Working Peak Reverse Voltage	30	V
V_R	DC Blocking Voltage	30	V
I_{FM}	Forward Continuous Current	200	mA
I_{FSM}	Non-repetitive Peak Forward Surge Current @t=8.3ms	600	mA
I_{FRM}	Repetitive Peak Forward Current @ t≤1s, δ≤0.5	300	mA
P_D	Power Dissipation	200	mW
$R_{\theta JA}$	Thermal Resistance from Junction to Ambient	500	°C/W
T_j	Junction Temperature	125	°C
T_{stg}	Storage Temperature	-55~+150	°C

ELECTRICAL CHARACTERISTICS (Ta = 25 °C)

Symbol	Parameter	Test Conditions	Min	Typ	Max	Units
$V_{(BR)}$	Reverse Voltage	$I_R=100\mu A$	30			V
I_R	Reverse Current	$V_R=25V$			2	uA
V_F	Forward Voltage	$I_F=0.1mA$			0.24	V
		$I_F=1mA$			0.32	V
		$I_F=10mA$			0.4	V
		$I_F=30mA$			0.5	V
		$I_F=100mA$			1	V
C_D	Diode Capacitance	$V_R=1V, f=1MHZ$			10	pF
t_{rr}	Reverse Recovery Time	$I_F=I_R=10mA$ $I_{rr}=0.1 \times I_R, R_L=100\Omega$			5	nS

TYPICAL CHARACTERISTICS

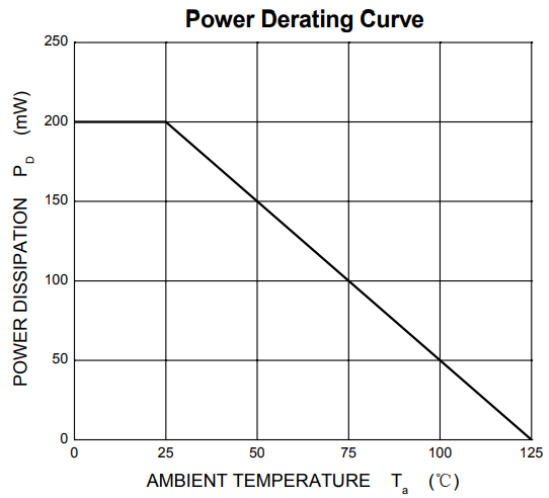
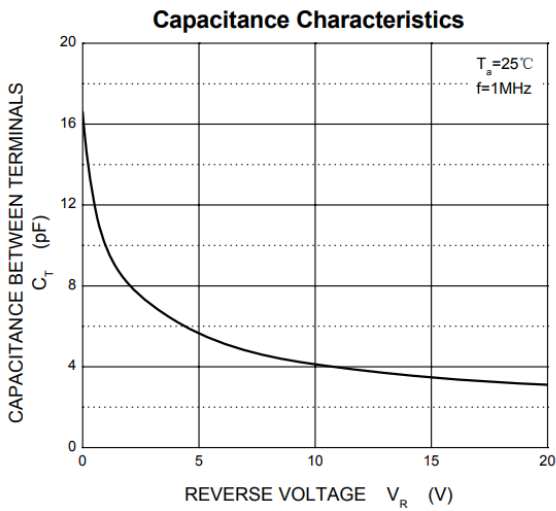
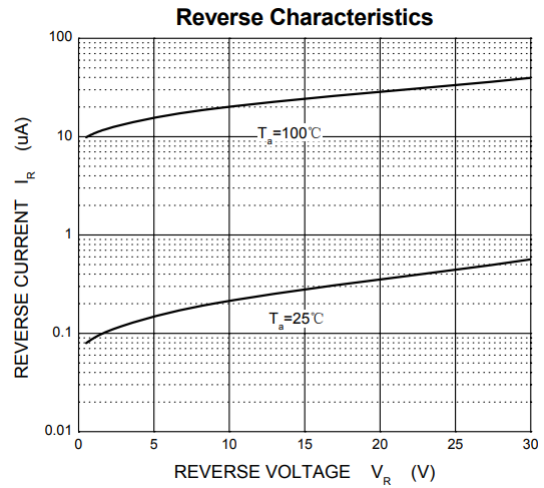
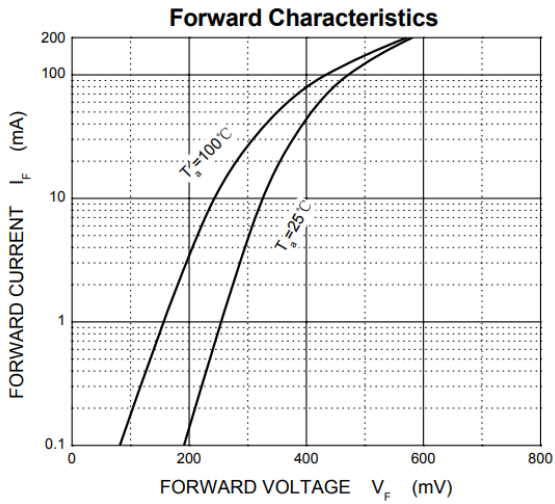

Pin Configuration – Top View

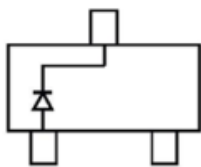

Figure1:BAT54WT

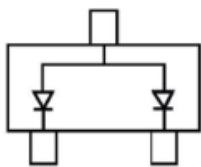

Figure2:BAT54AWT

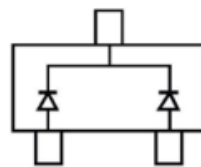

Figure3:BAT54CWT

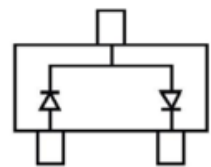

Figure4:BAT54SWT

ORDERING INFORMATION

Device	Package	Shipping	Tape wide	Emboss pitch	Tape specification	Notes
BAT54WT-BAT54S WT	SOT323	Tape & Reel 3000pcs /7" Reel	8mm	4mm	Conductive	

PACKAGE DIMENSIONS

Package outline : SOT323

TOP VIEW

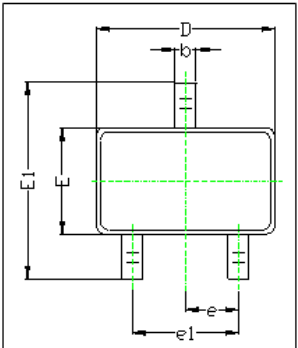

SIDE VIEW

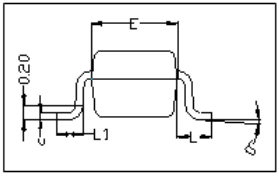

SYMBOL	DIMENSIONS IN MILLIMETER	
	MIN	MAX
A	0.900	1.000
A1	0.00	0.100
A2	0.900	1.000
b	0.200	0.400
c	0.080	0.150
D	2.000	2.200
E	1.150	1.350
E1	2.150	2.400
e	0.650 TYP.	
e1	1.200	1.400
L	0.525 REF.	
L1	0.260	0.450
θ	0°	8°

FRONT VIEW

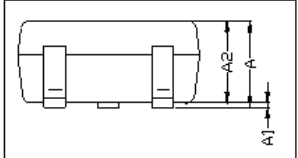

SOLDERING PATTERN

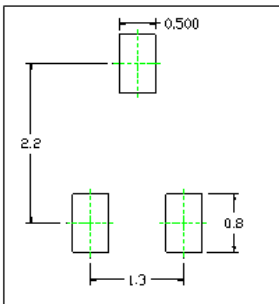

Notice:

1. Lead plating: Pb free solder
2. Lead thickness includes solder plating
3. Lead frame: CAC-5
4. Other Tolerance: ± 0.008
5. Dimensions are exclusive of Burs, Mold Flash and Tie Bar extrusions
6. Unit: mm