

Aug.1.2023 Copyright 2023 HIROSE ELECTRIC CO., LTD. All Rights Reserved.
In case of consideration for using Automotive equipment / device which demand high reliability, kindly contact our sales window correspondents.

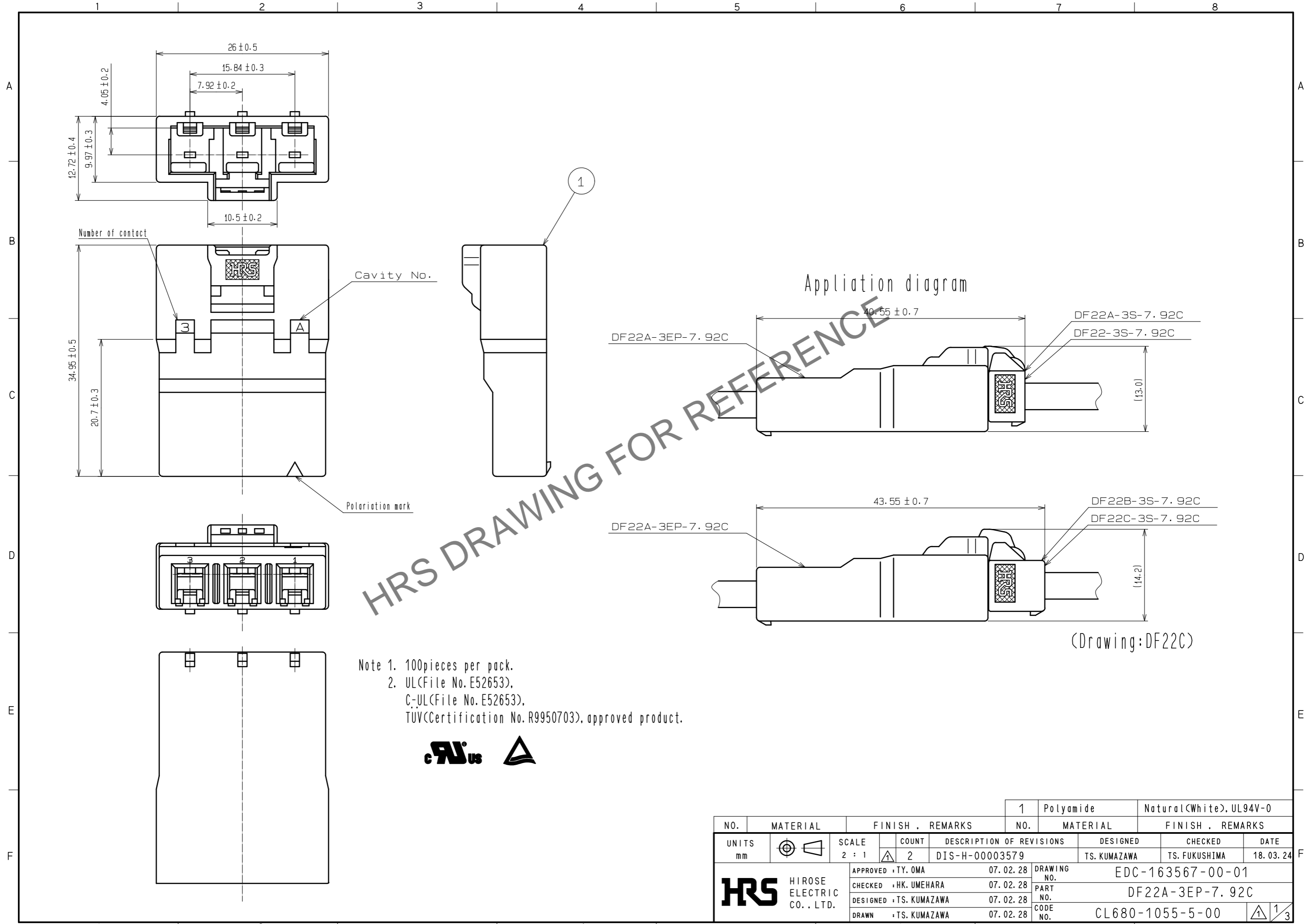

Note 1. 100pieces per pack.
2. UL(File No. E52653),
C-UL(File No. E52653),
TUV(Certification No. R9950703), approved product.



NO.		MATERIAL		FINISH . REMARKS		1		Polyamide		Natural(White).UL94V-0	
UNITS		SCALE		COUNT		DESCRIPTION OF REVISIONS		DESIGNED		CHECKED	
mm		2 : 1		2		DIS-H-00003579		TS. KUMAZAWA		TS. FUKUSHIMA	
APPROVED		TY. OMA		07.02.28		DRAWING NO.		EDC-163567-00-01			
CHECKED		HK. UMEHARA		07.02.28		PART NO.		DF22A-3EP-7.92C			
DESIGNED		TS. KUMAZAWA		07.02.28		CODE NO.		CL680-1055-5-00			
DRAWN		TS. KUMAZAWA		07.02.28		NO.		1/3			

Aug.1.2023 Copyright 2023 HIROSE ELECTRIC CO., LTD. All Rights Reserved.
In case of consideration for using Automotive equipment / device which demand high reliability, kindly contact our sales window correspondents.



Precautions

Notification for harness assembly

- 1) When inserting the crimping terminal to the crimping socket, please do not tilt the crimping terminal or twist the cable. Insertion at tilted angles or twisting the cable may cause deformation of the crimping terminal or crimping socket.
- 2) After inserting the crimping terminal to the crimping socket, please make sure that the lance has been hooked with pulling the cable lightly. When checking the hook, please avoid bending the cable for preventing terminal drop-off.

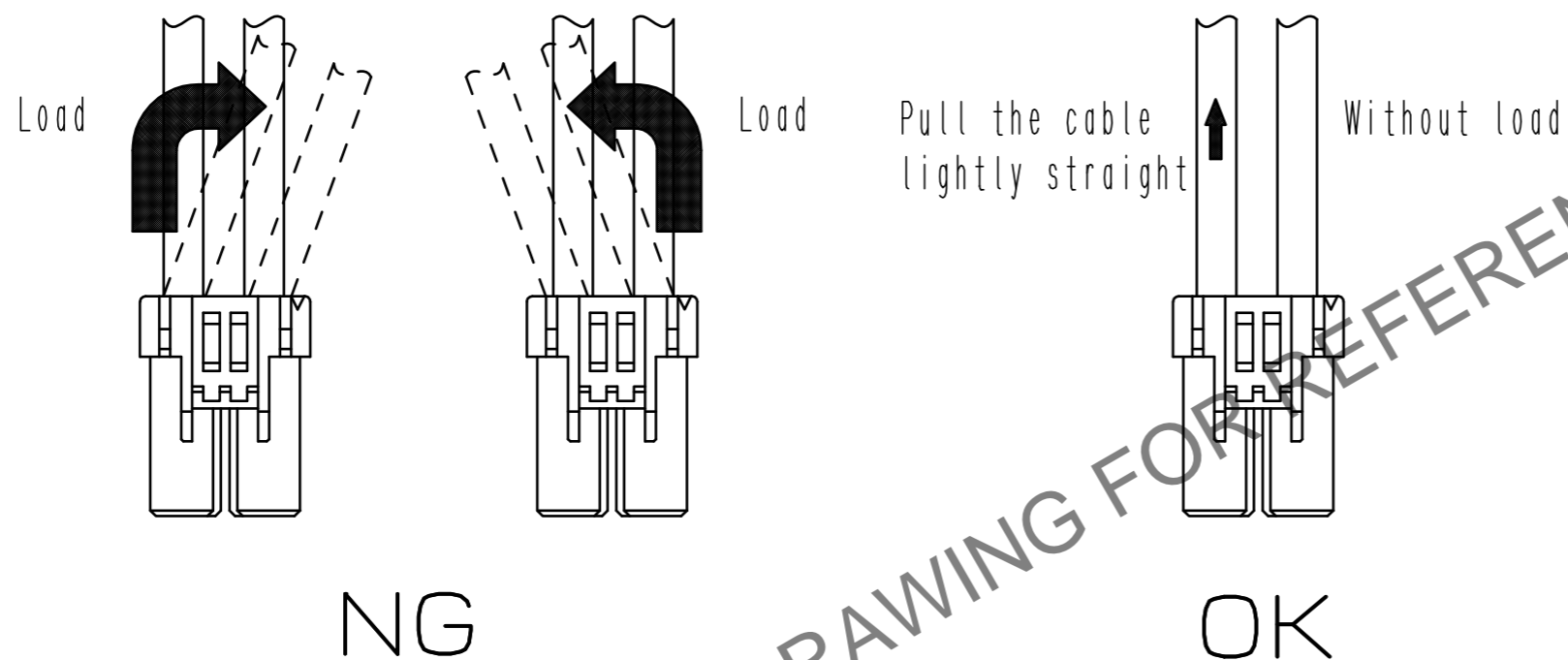

- 3) Bundle cables/Cable Cables
Recommend bundle and strip position of cables are 100 mm or more.
Bundling close to the connectors may cause terminal drop-off, breaking cables and unstable connection.

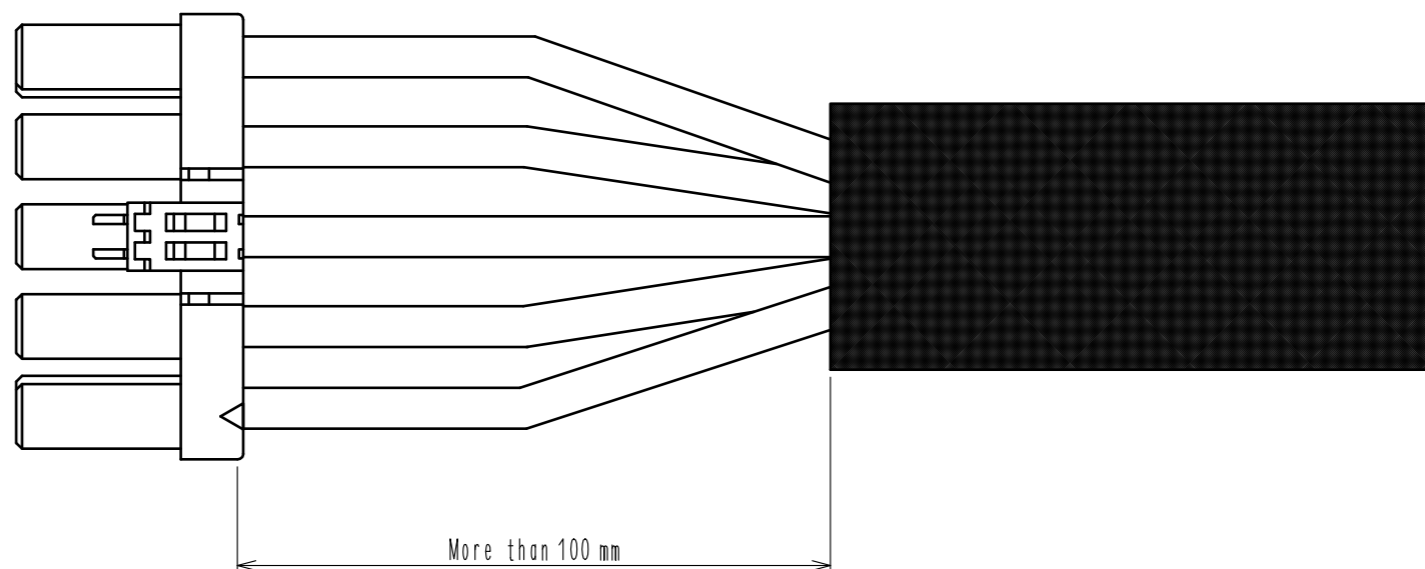

HRS

DRAWING NO.	EDC-163567-00-01
PART NO.	DF22A-3EP-7.92C
CODE NO.	CL680-1055-5-00

2/3

Aug.1.2023 Copyright 2023 HIROSE ELECTRIC CO., LTD. All Rights Reserved.
In case of consideration for using Automotive equipment / device which demand high reliability, kindly contact our sales window correspondents.



Precautions

Notification for Insertion/Extraction

- 1) Please insert(extract) the crimping socket straight to the mating connector.
Insertion(extraction) at tilted angles applies load concentration to the connector end and may cause deformation (at connection area, socket and header case, etc). There is firing risk using this kind of deformed connector.

Insertion(Extraction)

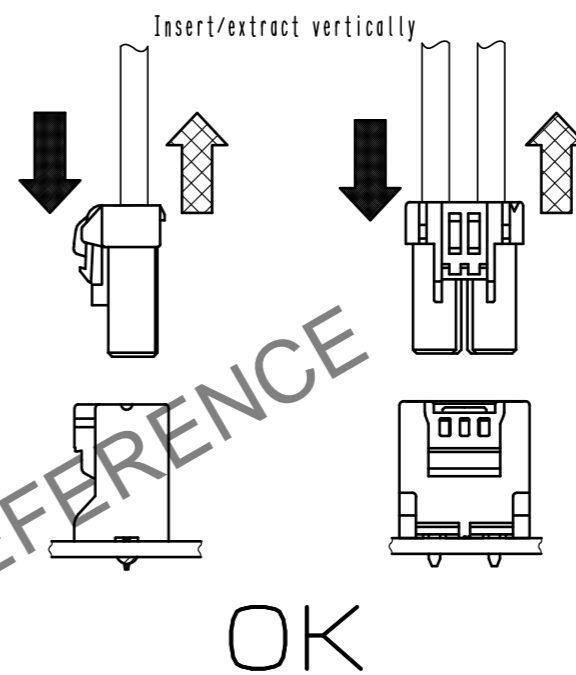
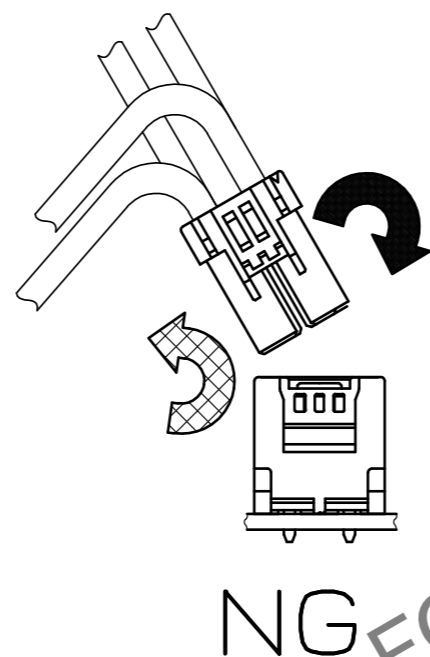
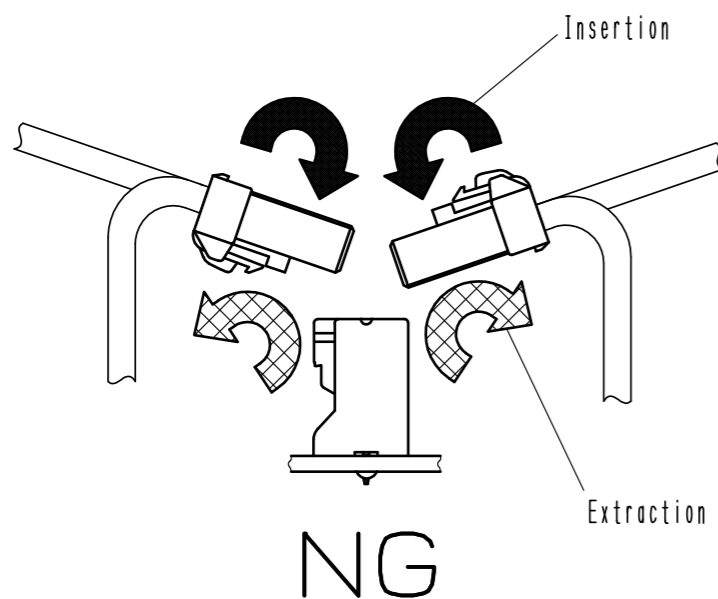

- 2) When it is hard to extract, please lightly insert the connector beforehand and then pull it with releasing the lock.
Forced extraction has a risk of connector breakage.

Notification of wiring

- 1) When using a thick cable, short cable length and bending close to the connector end, these load concentration may cause deformation.
Please note that there is firing risk using deformed connector.
When installing, please refrain from stress concentration such as cable bending close to the connector end or cable twisting.

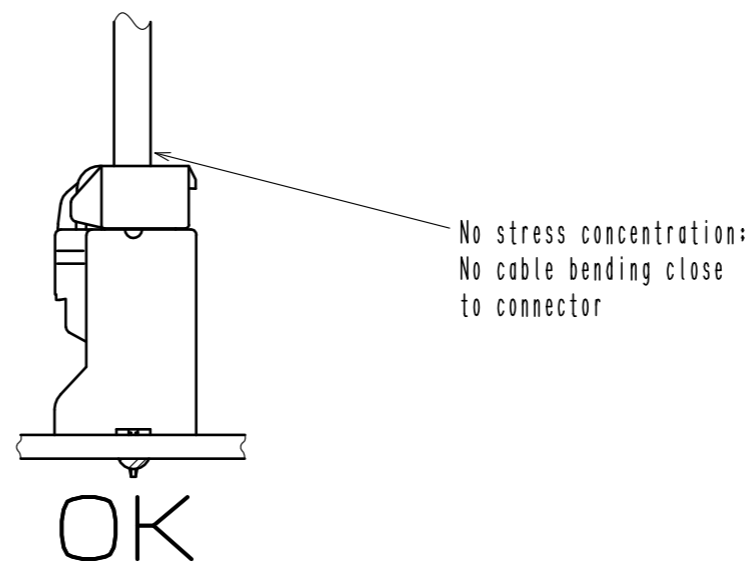
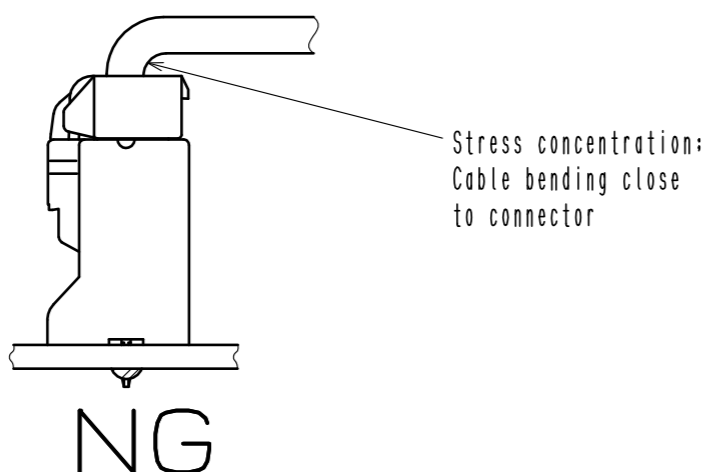

- 2) When applying load to connector end, please use the retainer for reducing the stress affection on the connector.
Retainer shall be installed after inserted crimping contact completely. It might be impossible to insert it when terminal installation is incompleated.



DRAWING NO.	EDC-163567-00-01
PART NO.	DF22A-3EP-7.92C
CODE NO.	CL680-1055-5-00