

Recommended P.C.B Layout  
General Tolerance±0.05

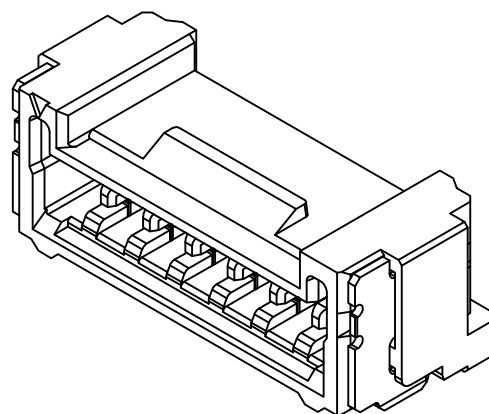
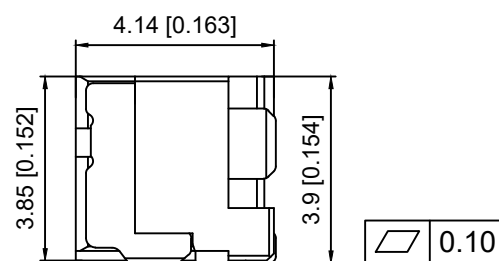

Specifications:

规格:

Voltage rating:50V AC/DC

额定电压: 50V AC/DC

Current rating:1.5A AC/DC

额定电流: 1.5A AC/DC

Withstanding voltage:500V AC/minute

耐受电压: 500V AC/分钟

Temperature range:-40℃~+125℃

温度范围: -40℃~+125℃

Insulation resistance:100MΩ min

绝缘电阻: 100MΩ Min

Contact resistance:20mΩ Max

接触电阻: 20mΩ Max

X1256 W R S - XX L - XX XX  
① ② ③ ④ ⑤ ⑥ ⑦ ⑧

- 1.Series No
- 2.Category:W-Wafer
- 3.Welding Board Range:R-Strighr 90°
- 4.Welding Way:S-SMT
- 5.Row No.Pin No:XX-02~16 Pin
- 6.Special No:L-Front buckle
- 7.Material:LP-LCP UL94V-0 (Black)  
6T-PA6T UL94V-0 (colours)
- 8.Plating:V01-Gold Flash ; SN-Plated Tin

Poles	Dimensions(mm)			Poles	Dimensions(mm)		
	A	B	C		A	B	C
02	1.25	5.75	4.90	10	11.25	15.75	14.90
03	2.54	7.00	6.15	11	12.50	17.00	16.15
04	3.75	8.25	7.40	12	13.75	18.25	17.40
05	5.00	9.50	8.65	13	15.00	19.50	18.65
06	6.25	10.75	9.90	14	16.25	20.75	19.90
07	7.50	12.00	11.15	16	17.50	22.00	21.15
08	8.75	13.25	12.40	16	18.75	23.25	22.40
09	10.00	14.50	13.65				/

X1256WRS-XXL-XXXX	LCP/PA6T	Phosphor Bronze	X1256H-L
PART NO	Material	Material(Pin)	Suitable XKB Housing

DSND		SCALE: N/A	MODEL TYPE: 1.25mm Crimp Style Connector
DWN		VIEW:	PART NO.: X1256WRS-XXL-XXXX
CHKD		UNIT: mm/in	DWG NO.: X-X1256WRS-XXL-XXXX
APPD		SIZE: A4	



XKB INDUSTRIAL PRECISION CO.,LIMITED

WEIGHT	SHEET	REVISION
	1/1	A0

MARK	DESCRIPTION	DATE	REVISED	APPROVED	UNSPECIFIED TOLERANCES
ΔX					ANGULAR ±5°
ΔX					L ≤ 4 ±0.2
ΔX					4 < L ≤ 16 ±0.3
					16 < L ≤ 63 ±0.4
					L > 63 ±0.5