

3 TERMINAL 1.5A NEGATIVE VOLTAGE REGULATOR

FEATURES

- *Output current in excess of 1.5A
- *-5,-6,-8,-9,-10,-12,-15V output voltages available
- *Internal Thermal overload protection
- *Short circuit protection
- *Output transistor SOA protection

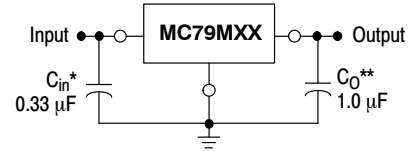

BLOCK DIAGRAM

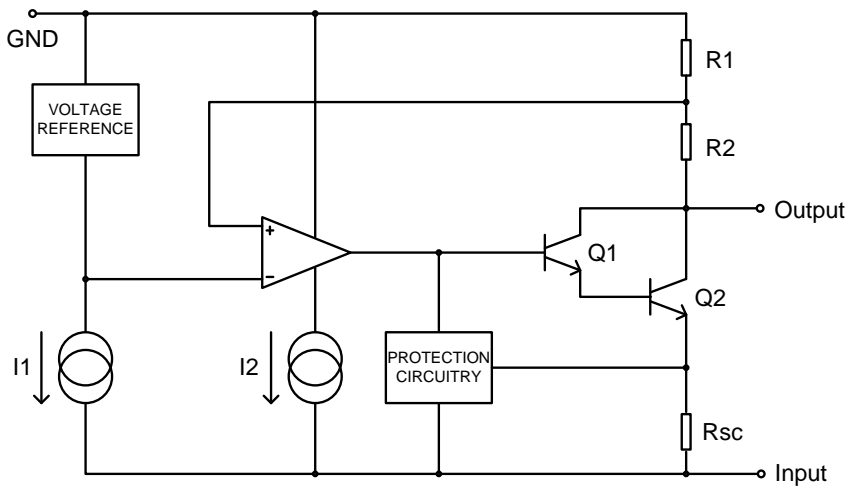

ABSOLUTE MAXIMUM RATINGS ($T_a=25^\circ\text{C}$)

Characteristic	Symbol	Value	Unit
Input voltage	V_i	-35	V
Thermal resistance junction-air	$R_{\theta JA}$	65	$^\circ\text{C}/\text{W}$
Thermal resistance junction-cases	$R_{\theta JC}$	5	$^\circ\text{C}/\text{W}$
Operating Temperature	T_{opr}	0~+125	$^\circ\text{C}$
Storage Temperature	T_{stg}	-65~+150	$^\circ\text{C}$

Note:

- Thermal resistance test board
Size: 76.2mmX114.3mmX1.6mm(1S0P)
JEDEC standard: JESD51-3, JESD51-7
- Assume no ambient airflow

7905 ELECTRICAL CHARACTERISTICS

 (Refer to test circuits, $0 < T_j < 125^\circ\text{C}$, $I_o=500\text{mA}$, $V_i=-10\text{V}$, $C_i=2.2\mu\text{F}$, $C_o=1\mu\text{F}$, unless otherwise specified)

Characteristic	Symbol	Test Conditions	Min	Typ	Max	Units
Output voltage	V_o	$T_j=25^\circ\text{C}$	-4.8	-5.0	-5.2	V
		$5\text{mA} < I_o < 1\text{A}$, $P_o < 15\text{W}$ $V_i = -7\text{V to } -20\text{V}$	-4.75	-5.0	-5.25	
Line regulation(Note)	ΔV_o	$T_j=25^\circ\text{C}$, $V_i = -7\text{V to } -25\text{V}$	-	35	100	mV
		$T_j=25^\circ\text{C}$, $V_i = -8\text{V to } -12\text{V}$	-	8	50	
Load regulation(Note)	ΔV_o	$T_j=25^\circ\text{C}$, $I_o = 5\text{mA to } 1.5\text{A}$	-	10	100	mV
		$T_j=25^\circ\text{C}$, $I_o = 250\text{mA to } 750\text{mA}$	-	3	50	
Quiescent current	I_Q	$T_j=25^\circ\text{C}$	-	3	6	mA
Quiescent current change	ΔI_Q	$I_o = 5\text{mA to } 1\text{A}$	-	0.05	0.5	mA
		$V_i = -8\text{V to } -25\text{V}$	-	0.1	0.8	
Temperature coefficient of VD	$\Delta V_o/\Delta T$	$I_o = 5\text{mA}$	-	0.5	-	mV/ $^\circ\text{C}$
Output noise voltage	V_N	$f = 10\text{Hz to } 100\text{kHz}$, $T_a = 25^\circ\text{C}$	-	40	-	μV
Ripple rejection	RR	$f = 120\text{Hz}$, $\Delta V_i = 10\text{V}$	54	60	-	dB
Dropout voltage	VD	$I_o = 1\text{A}$, $T_j = 25^\circ\text{C}$	-	2	-	V
Short circuit current	I_{sc}	$V_i = -35\text{V}$, $T_j = 25^\circ\text{C}$	-	10	-	mA

 Note: Load and line regulation are specified at constant junction temperature. Changes in V_O due to heating effects must be taken into account separately. Pulse testing with low duty is used.

7906 ELECTRICAL CHARACTERISTICS

(Refer to test circuits, $0 < T_j < 125^\circ\text{C}$, $I_o = 500\text{mA}$, $V_i = -11\text{V}$, $C_i = 2.2\mu\text{F}$, $C_o = 1\mu\text{F}$, unless otherwise specified)

Characteristic	Symbol	Test Conditions	Min	Typ	Max	Units
Output voltage	V_o	$T_j = 25^\circ\text{C}$	-5.75	-6	-6.25	V
		$5\text{mA} < I_o < 1\text{A}$, $P_o < 15\text{W}$ $V_i = -9\text{V}$ to -21V	-5.7	-6	-6.3	
Line regulation(Note)	ΔV_o	$T_j = 25^\circ\text{C}$, $V_i = -8\text{V}$ to -25V	-	10	120	mV
		$T_j = 25^\circ\text{C}$, $V_i = -9\text{V}$ to -13V	-	5	60	
Load regulation(Note)	ΔV_o	$T_j = 25^\circ\text{C}$, $I_o = 5\text{mA}$ to 1.5A	-	10	120	mV
		$T_j = 25^\circ\text{C}$, $I_o = 250\text{mA}$ to 750mA	-	3	60	
Quiescent current	I_Q	$T_j = 25^\circ\text{C}$	-	3	6	mA
Quiescent current change	ΔI_Q	$I_o = 5\text{mA}$ to 1A	-	0.05	0.5	mA
		$V_i = -8\text{V}$ to -25V	-	0.1	1	
Temperature coefficient of VD	$\Delta V_o / \Delta T$	$I_o = 5\text{mA}$	-	0.6	-	mV/ $^\circ\text{C}$
Output noise voltage	VN	$f = 10\text{Hz}$ to 100kHz , $T_a = 25^\circ\text{C}$	-	130	-	μV
Ripple rejection	RR	$f = 120\text{Hz}$, $\Delta V_i = 10\text{V}$	54	60	-	dB
Dropout voltage	VD	$I_o = 1\text{A}$, $T_j = 25^\circ\text{C}$	-	2	-	V
Short circuit current	Isc	$V_i = -35\text{V}$, $T_j = 25^\circ\text{C}$	-	10	-	mA

Note: Load and line regulation are specified at constant junction temperature. Changes in V_o due to heating effects must be taken into account separately. Pulse testing with low duty is used.

7908 ELECTRICAL CHARACTERISTICS

(Refer to test circuits, $0 < T_j < 125^\circ\text{C}$, $I_o = 500\text{mA}$, $V_i = -14\text{V}$, $C_i = 2.2\mu\text{F}$, $C_o = 1\mu\text{F}$, unless otherwise specified)

Characteristic	Symbol	Test Conditions	Min	Typ	Max	Units
Output voltage	V_o	$T_j = 25^\circ\text{C}$	-7.7	-8	-8.3	V
		$5\text{mA} < I_o < 1\text{A}$, $P_o < 15\text{W}$ $V_i = -10\text{V}$ to -23V	-7.6	-8	-8.4	
Line regulation(Note)	ΔV_o	$T_j = 25^\circ\text{C}$, $V_i = -10.5\text{V}$ to -25V	-	10	160	mV
		$T_j = 25^\circ\text{C}$, $V_i = -11\text{V}$ to -17V	-	5	80	
Load regulation(Note)	ΔV_o	$T_j = 25^\circ\text{C}$, $I_o = 5\text{mA}$ to 1.5A	-	12	160	mV
		$T_j = 25^\circ\text{C}$, $I_o = 250\text{mA}$ to 750mA	-	4	80	
Quiescent current	I_Q	$T_j = 25^\circ\text{C}$	-	3	6	mA
Quiescent current change	ΔI_Q	$I_o = 5\text{mA}$ to 1A	-	0.05	0.5	mA
		$V_i = -10.5\text{V}$ to -25V	-	0.1	1	
Temperature coefficient of VD	$\Delta V_o / \Delta T$	$I_o = 5\text{mA}$	-	0.8	-	mV/ $^\circ\text{C}$
Output noise voltage	VN	$f = 10\text{Hz}$ to 100kHz , $T_a = 25^\circ\text{C}$	-	175	-	μV
Ripple rejection	RR	$f = 120\text{Hz}$, $\Delta V_i = 10\text{V}$	54	60	-	dB
Dropout voltage	VD	$I_o = 1\text{A}$, $T_j = 25^\circ\text{C}$	-	2	-	V
Short circuit current	Isc	$V_i = -35\text{V}$, $T_j = 25^\circ\text{C}$	-	10	-	mA

Note: Load and line regulation are specified at constant junction temperature. Changes in V_o due to heating effects must be taken into account separately. Pulse testing with low duty is used.

7909 ELECTRICAL CHARACTERISTICS

 (Refer to test circuits, $0 < T_j < 125^\circ\text{C}$, $I_o = 500\text{mA}$, $V_i = -15\text{V}$, $C_i = 2.2\mu\text{F}$, $C_o = 1\mu\text{F}$, unless otherwise specified)

Characteristic	Symbol	Test Conditions	Min	Typ	Max	Units
Output voltage	V_o	$T_j = 25^\circ\text{C}$	-8.7	-9.0	-9.3	V
		$5\text{mA} < I_o < 1\text{A}$, $P_o < 15\text{W}$ $V_i = -7\text{V to } -20\text{V}$	-8.6	-9.0	-9.4	
Line regulation(Note1)	ΔV_o	$T_j = 25^\circ\text{C}$, $V_i = -11.5\text{V to } -26\text{V}$	-	10	180	mV
		$T_j = 25^\circ\text{C}$, $V_i = -12\text{V to } -18\text{V}$	-	5	90	
Load regulation(Note1)	ΔV_o	$T_j = 25^\circ\text{C}$, $I_o = 5\text{mA to } 1.5\text{A}$	-	12	180	mV
		$T_j = 25^\circ\text{C}$, $I_o = 250\text{mA to } 750\text{mA}$	-	4	90	
Quiescent current	I_Q	$T_j = 25^\circ\text{C}$	-	3	6	mA
Quiescent current change	ΔI_Q	$I_o = 5\text{mA to } 1\text{A}$	-	0.05	0.5	mA
		$V_i = -11.5\text{V to } -26\text{V}$	-	0.1	1	
Temperature coefficient of V_D	$\Delta V_o / \Delta T$	$I_o = 5\text{mA}$	-	0.9	-	mV/ $^\circ\text{C}$
Output noise voltage	V_N	$f = 10\text{Hz to } 100\text{kHz}$, $T_a = 25^\circ\text{C}$	-	175	-	μV
Ripple rejection	RR	$f = 120\text{Hz}$, $\Delta V_i = 10\text{V}$	54	60	-	dB
Dropout voltage	V_D	$I_o = 1\text{A}$, $T_j = 25^\circ\text{C}$	-	2	-	V
Short circuit current	Isc	$V_i = -35\text{V}$, $T_j = 25^\circ\text{C}$	-	10	-	mA

 Note: Load and line regulation are specified at constant junction temperature. Changes in V_O due to heating effects must be taken into account separately. Pulse testing with low duty is used.

7910 ELECTRICAL CHARACTERISTICS

 (Refer to test circuits, $0 < T_j < 125^\circ\text{C}$, $I_o = 500\text{mA}$, $V_i = -17\text{V}$, $C_i = 2.2\mu\text{F}$, $C_o = 1\mu\text{F}$, unless otherwise specified)

Characteristic	Symbol	Test Conditions	Min	Typ	Max	Units
Output voltage	V_o	$T_j = 25^\circ\text{C}$	-9.6	-10	-10.4	V
		$5\text{mA} < I_o < 1\text{A}$, $P_o < 15\text{W}$ $V_i = -10\text{V to } -23\text{V}$	-9.5	-10	-10.5	
Line regulation(Note)	ΔV_o	$T_j = 25^\circ\text{C}$, $V_i = -12.5\text{V to } -28\text{V}$	-	12	200	mV
		$T_j = 25^\circ\text{C}$, $V_i = -14\text{V to } -20\text{V}$	-	6	100	
Load regulation(Note)	ΔV_o	$T_j = 25^\circ\text{C}$, $I_o = 5\text{mA to } 1.5\text{A}$	-	12	200	mV
		$T_j = 25^\circ\text{C}$, $I_o = 250\text{mA to } 750\text{mA}$	-	4	100	
Quiescent current	I_Q	$T_j = 25^\circ\text{C}$	-	3	6	mA
Quiescent current change	ΔI_Q	$I_o = 5\text{mA to } 1\text{A}$	-	0.05	0.5	mA
		$V_i = -12.5\text{V to } -28\text{V}$	-	0.1	1	
Temperature coefficient of V_D	$\Delta V_o / \Delta T$	$I_o = 5\text{mA}$	-	1.0	-	mV/ $^\circ\text{C}$
Output noise voltage	V_N	$f = 10\text{Hz to } 100\text{kHz}$, $T_a = 25^\circ\text{C}$	-	280	-	μV
Ripple rejection	RR	$f = 120\text{Hz}$, $\Delta V_i = 10\text{V}$	54	60	-	dB
Dropout voltage	V_D	$I_o = 1\text{A}$, $T_j = 25^\circ\text{C}$	-	2	-	V
Short circuit current	Isc	$V_i = -35\text{V}$, $T_j = 25^\circ\text{C}$	-	10	-	mA

 Note: Load and line regulation are specified at constant junction temperature. Changes in V_O due to heating effects must be taken into account separately. Pulse testing with low duty is used.

7912 ELECTRICAL CHARACTERISTICS

 (Refer to test circuits, $0 < T_j < 125^\circ\text{C}$, $I_o = 500\text{mA}$, $V_i = -19\text{V}$, $C_i = 2.2\mu\text{F}$, $C_o = 1\mu\text{F}$, unless otherwise specified)

Characteristic	Symbol	Test Conditions	Min	Typ	Max	Units
Output voltage	V_o	$T_j = 25^\circ\text{C}$	-11.5	-12	-12.5	V
		$5\text{mA} < I_o < 1\text{A}$, $P_o < 15\text{W}$ $V_i = -7\text{V to } -20\text{V}$	-11.4	-12	-12.6	
Line regulation(Note1)	ΔV_o	$T_j = 25^\circ\text{C}$, $V_i = -14.5\text{V to } -30\text{V}$	-	12	240	mV
		$T_j = 25^\circ\text{C}$, $V_i = -16\text{V to } -22\text{V}$	-	6	120	
Load regulation(Note1)	ΔV_o	$T_j = 25^\circ\text{C}$, $I_o = 5\text{mA to } 1.5\text{A}$	-	12	240	mV
		$T_j = 25^\circ\text{C}$, $I_o = 250\text{mA to } 750\text{mA}$	-	4	120	
Quiescent current	I_Q	$T_j = 25^\circ\text{C}$	-	3	6	mA
Quiescent current change	ΔI_Q	$I_o = 5\text{mA to } 1\text{A}$	-	0.05	0.5	mA
		$V_i = -14.5\text{V to } -30\text{V}$	-	0.1	1	
Temperature coefficient of V_D	$\Delta V_o / \Delta T$	$I_o = 5\text{mA}$	-	1.2	-	mV/ $^\circ\text{C}$
Output noise voltage	V_N	$f = 10\text{Hz to } 100\text{kHz}$, $T_a = 25^\circ\text{C}$	-	200	-	μV
Ripple rejection	RR	$f = 120\text{Hz}$, $\Delta V_i = 10\text{V}$	54	60	-	dB
Dropout voltage	V_D	$I_o = 1\text{A}$, $T_j = 25^\circ\text{C}$	-	2	-	V
Short circuit current	Isc	$V_i = -35\text{V}$, $T_j = 25^\circ\text{C}$	-	10	-	mA

 Note: Load and line regulation are specified at constant junction temperature. Changes in V_O due to heating effects must be taken into account separately. Pulse testing with low duty is used.

7915 ELECTRICAL CHARACTERISTICS

 (Refer to test circuits, $0 < T_j < 125^\circ\text{C}$, $I_o = 500\text{mA}$, $V_i = -23\text{V}$, $C_i = 2.2\mu\text{F}$, $C_o = 1\mu\text{F}$, unless otherwise specified)

Characteristic	Symbol	Test Conditions	Min	Typ	Max	Units
Output voltage	V_o	$T_j = 25^\circ\text{C}$	-14.4	-15	-15.6	V
		$5\text{mA} < I_o < 1\text{A}$, $P_o < 15\text{W}$ $V_i = -7\text{V to } -20\text{V}$	-14.25	-15	-15.75	
Line regulation(Note1)	ΔV_o	$T_j = 25^\circ\text{C}$, $V_i = -17.5\text{V to } -30\text{V}$	-	12	300	mV
		$T_j = 25^\circ\text{C}$, $V_i = -20\text{V to } -26\text{V}$	-	6	150	
Load regulation(Note1)	ΔV_o	$T_j = 25^\circ\text{C}$, $I_o = 5\text{mA to } 1.5\text{A}$	-	12	300	mV
		$T_j = 25^\circ\text{C}$, $I_o = 250\text{mA to } 750\text{mA}$	-	4	150	
Quiescent current	I_Q	$T_j = 25^\circ\text{C}$	-	3	6	mA
Quiescent current change	ΔI_Q	$I_o = 5\text{mA to } 1\text{A}$	-	0.05	0.5	mA
		$V_i = -17.5\text{V to } -30\text{V}$	-	0.1	1	
Temperature coefficient of V_D	$\Delta V_o / \Delta T$	$I_o = 5\text{mA}$	-	1.5	-	mV/ $^\circ\text{C}$
Output noise voltage	V_N	$f = 10\text{Hz to } 100\text{kHz}$, $T_a = 25^\circ\text{C}$	-	250	-	μV
Ripple rejection	RR	$f = 120\text{Hz}$, $\Delta V_i = 10\text{V}$	54	60	-	dB
Dropout voltage	V_D	$I_o = 1\text{A}$, $T_j = 25^\circ\text{C}$	-	2	-	V
Short circuit current	Isc	$V_i = -35\text{V}$, $T_j = 25^\circ\text{C}$	-	10	-	mA

 Note: Load and line regulation are specified at constant junction temperature. Changes in V_O due to heating effects must be taken into account separately. Pulse testing with low duty is used.

APPLICATION CIRCUITS

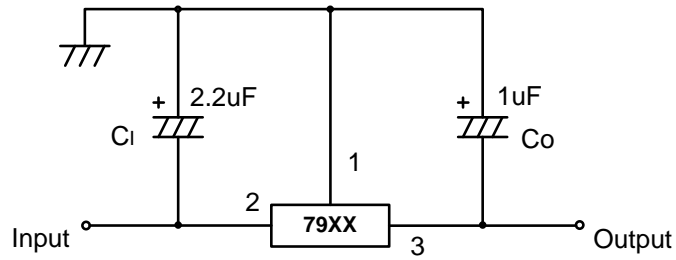

Fig.1 Negative fixed output regulator

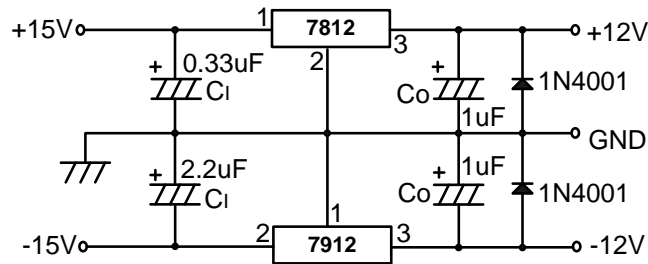

Fig.2 Split power supply($\pm 12V/1A$)