

## Up to 24V Supply, 4-A Single Channel High Speed Low Side Driver

### FEATURES

- Wide Supply Voltage Range: 4.5V - 24V
- 4A Peak Source Current and 4A Peak Sink Current
- Dual Input Configuration: Non-Inverting (IN+) or Inverting (IN-) Input
- Negative Input Voltage Capability: Down to -5V
- TTL Input-Logic Threshold
- Propagation Delay: 12ns
- Fast Rising and Falling Time: 9ns and 6ns
- Low Quiescent Current: 38uA
- Under Voltage Lock Out Protection of Supply Voltage
- Output Low When Input Floating
- Thermal Shutdown Protection: 170°C
- Available in TSOT23-5L Package

### APPLICATIONS

- Power MOSFET Gate Driver
- IGBT Gate Driver
- GaN Device Gate Driver
- Switching Power Supply
- Motor Control, Solar Power

### TYPICAL APPLICATION

1EDN7512 Typical Application

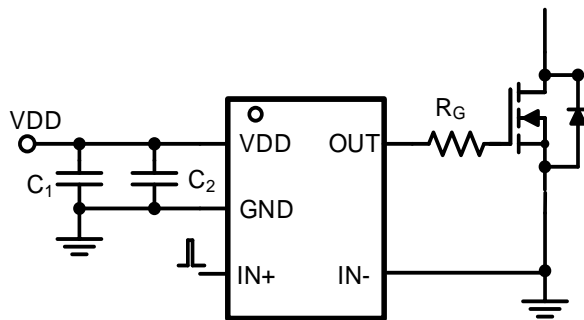

Application Waveform

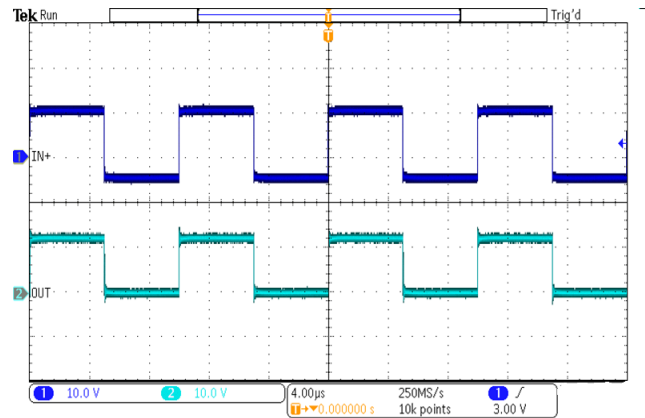

## DEVICE ORDER INFORMATION

PART NUMBER	PACKAGE MARKING	PACKAGE DISCRIPTION
1EDN7512	1240	TSOT-23-5

## ABSOLUTE MAXIMUM RATINGS

Over operating free-air temperature unless otherwise noted<sup>(1)</sup>

DESCRIPTION	MIN	MAX	UNIT
IN+, IN-	-5	26	V
OUT	-0.3	26	V
VDD	-0.3	26	V
Operating junction temperature $T_J$ <sup>(2)</sup>	-40	150	°C
Storage temperature $T_{STG}$	-65	150	°C

(1) Stresses beyond those listed under Absolut Maximum Rating may cause device permanent damage. The device is not guaranteed to function outside of its Recommended Operation Conditions.

(2) The IC includes over temperature protection to protect the device during overload conditions. Junction temperature will exceed 150°C when over temperature protection is active. Continuous operation above the specified maximum operating junction temperature will reduce lifetime

## PIN CONFIGURATION

Top View: TSOT23-5pin  
Plastic

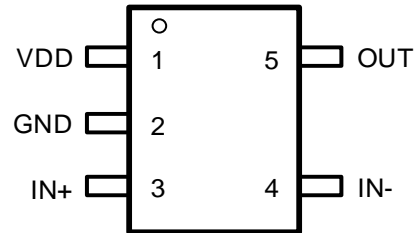

## PIN FUNCTIONS

NAME	NO.	PIN FUNCTION
VDD	1	Power supply of gate driver, must be decoupled by ceramic cap. A 0.1uF, and 1uF or 10uF are recommended.
GND	2	Power ground. Must be soldered directly to ground planes for improved thermal performance and electrical contact.
IN+	3	Non-inverting logic input, TTL compatible. Floating logic low. In Non-Inverting configuration, apply PWM signal on IN+. In inverting configuration, connect IN+ to VDD.
IN-	4	Inverting logic input, TTL compatible. Floating logic low. In Non-Inverting configuration, connect IN- to GND. In inverting configuration, apply PWM signal on IN-.
OUT	5	Gate driver output.

## RECOMMENDED OPERATING CONDITIONS

Over operating free-air temperature range unless otherwise noted

PARAMETER	DEFINITION	MIN	MAX	UNIT
V <sub>DD</sub>	Supply voltage range	4.5	24	V
V <sub>IN+,IN-</sub>	Input voltage range	-5	24	V
T <sub>J</sub>	Operating junction temperature	-40	150	°C

## ESD RATINGS

PARAMETER	DEFINITION	MIN	MAX	UNIT
V <sub>ESD</sub>	Human Body Model (HBM), per ANSI-JEDEC-JS-001-2014 specification, all pins <sup>(1)</sup>	-2	+2	kV
	Charged Device Model (CDM), per ANSI-JEDEC-JS-002-2014 specification, all pins <sup>(1)</sup>	-1	+1	kV

(1) HBM and CDM stressing are done in accordance with the ANSI/ESDA/JEDEC JS-001-2014 specification

## THERMAL INFORMATION

PARAMETER	THERMAL METRIC	TSOT23-5	UNIT
R <sub>θJA</sub>	Junction to ambient thermal resistance	89	°C/W
R <sub>θJC</sub>	Junction to case thermal resistance	39	

## ELECTRICAL CHARACTERISTICS

$V_{DD}=12V$ ,  $T_J=-40^{\circ}C\sim 125^{\circ}C$ , typical values are tested under  $25^{\circ}C$ .

SYMBOL	PARAMETER	TEST CONDITION	MIN	TYP	MAX	UNIT
<b>Power Supply and Output</b>						
$V_{DD}$	Operating supply voltage		4.5		24	V
$V_{DD\_UVLO}$	Input UVLO Hysteresis	$V_{DD}$ rising		4.2 300	4.5	V mV
$I_Q$	Quiescent current	$IN+=IN-=GND$ , $V_{DD}=3.5V$		38		$\mu A$
		$IN+=IN-=GND$ , $V_{DD}=12V$		120		$\mu A$
<b>INPUTS</b>						
$V_{IN+}$	Input+ logic high threshold			2.1	2.4	V
$V_{IN+}$	Input+ logic low threshold		0.8	1.0		V
$V_{IN+\_Hys}$	Hysteresis			1.1		V
$V_{IN\_H}$	Input- logic high threshold			2.1	2.4	V
$V_{IN\_L}$	Input- logic low threshold		0.8	1.0		V
$V_{IN\_Hys}$	Hysteresis			1.1		V
<b>OUTPUTS</b>						
$V_{DD\_VOH}$	Output High Voltage (only PMOS ON)	$I_{OUT}=10mA$			150	mV
$V_{OL}$	Output Low Voltage	$I_{OUT}=10mA$			10	mV
$I_{SINK/SRC}$	Output Sink/Source peak current	$C_{Load}=10nF$ , $F_{sw}=1kHz$		4		A
$R_{OH}$	Output pull high resistance (only PMOS ON)	$I_{OUT}= - 10mA$		8.5		$\Omega$
$R_{OL}$	Output pull low resistance	$I_{OUT}= 10mA$		0.6		$\Omega$
<b>Timing</b>						
$T_R$	Output rising time	$C_{Load}=1nF$		9	20	ns
$T_F$	Output falling time	$C_{Load}=1nF$		6	20	ns
$T_{D\_IN+}$	IN+ to output propagation delay, Rising edge			12	25	ns
	IN+ to output propagation delay, Falling edge			12	25	ns
$T_{D\_IN-}$	IN- to output propagation delay, Rising			12	25	ns
	IN- to output propagation delay, Falling			12	25	ns
$T_{MIN\_ON}$	Minimum input pulse width	$C_{Load}=1nF$		20	30	ns
<b>Protection</b>						
$T_{SD}$	Thermal shutdown threshold	$T_J$ rising		170		$^{\circ}C$
	Hysteresis			25		$^{\circ}C$

## TYPICAL CHARACTERISTICS

$V_{DD}=12V$ ,  $T_A=25^{\circ}C$ .

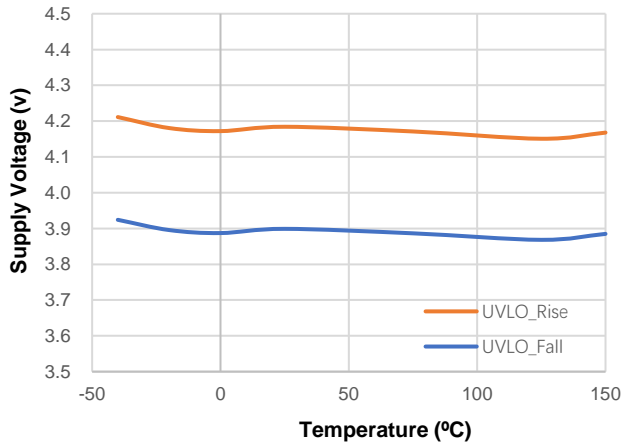

Figure 1. UVLO Vs Temperature

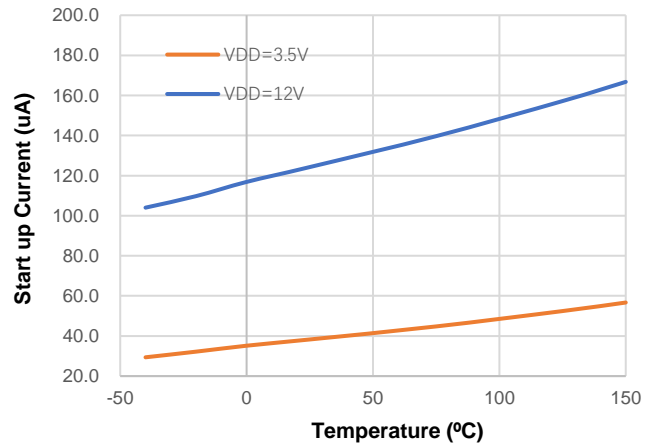

Figure 2. Start-up current Vs Temperature

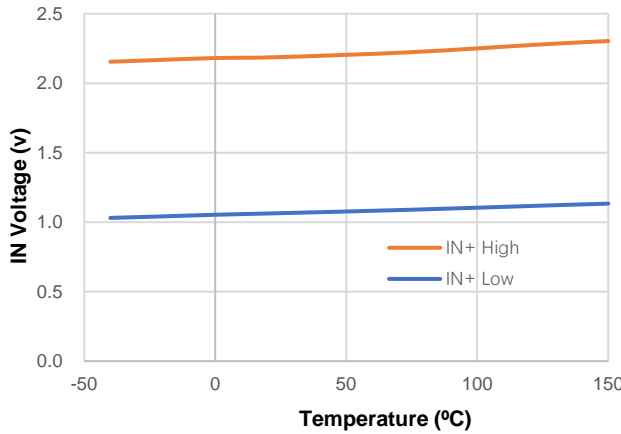

Figure 3. IN Threshold Vs Temperature

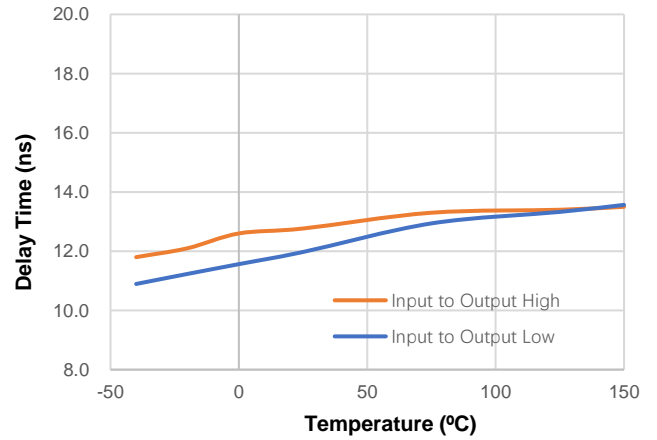

Figure 4. Input to Output Propagation Delay vs Temperature

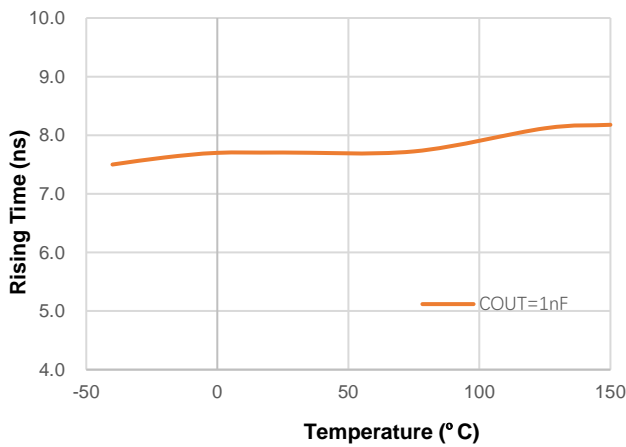

Figure 5. Output Rising Time Vs Temperature

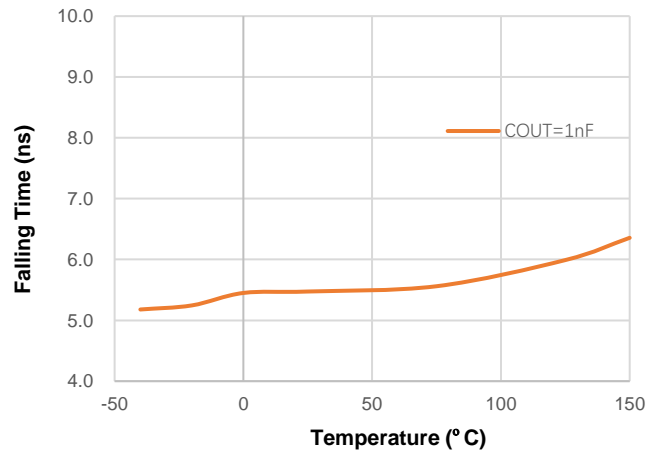

Figure 6. Output Falling Time Vs Temperature

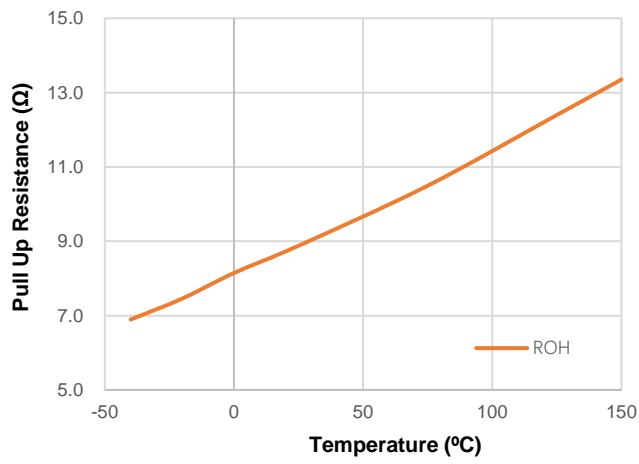

Figure 7. ROH vs Temperature

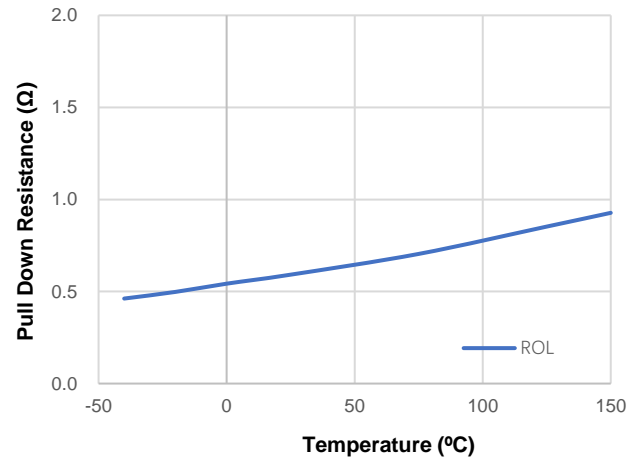
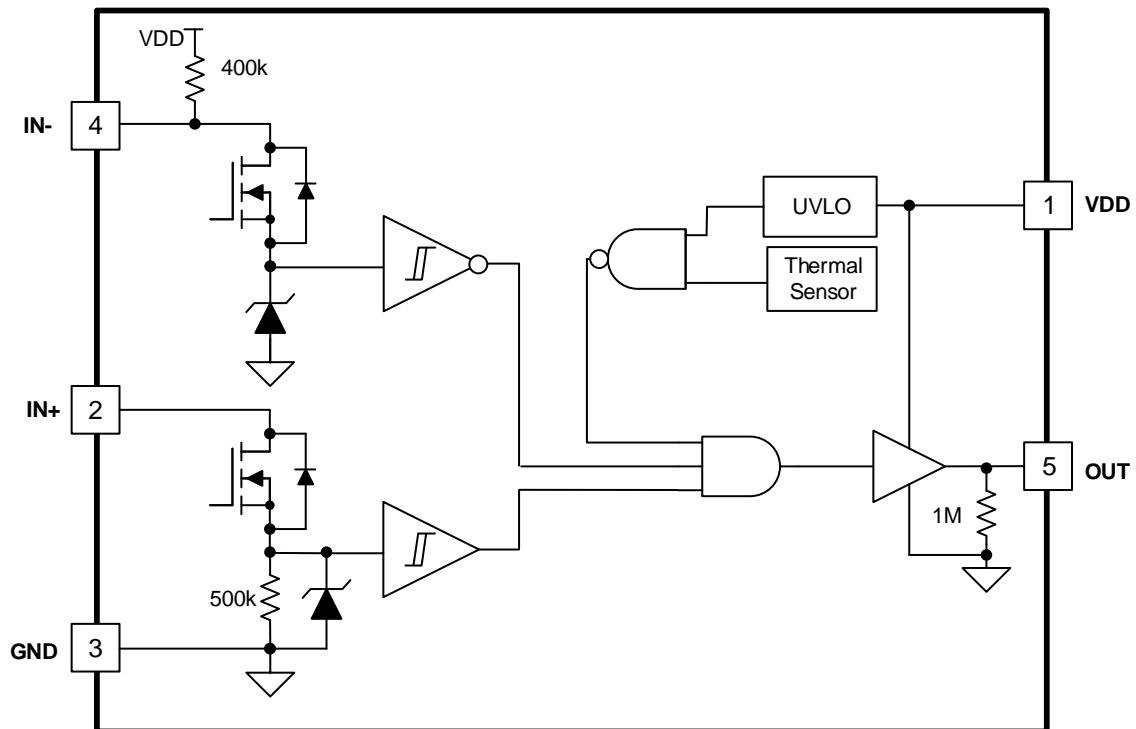

Figure 8. ROL Vs Frequency

## FUNCTIONAL BLOCK DIAGRAM



## OPERATION

### Overview

The 1EDN7512 is a up to 24V wide supply, single channel, high speed, low side gate driver for power MOSFET and IGBT. The 1EDN7512 can source and sink 4A peak current along with the minimum propagation delay 12ns from input to output. The ability to handle -5V DC input increases the driver input stage noise immunity, the 24V rail-to-rail output improves the 1EDN7512 output stage robustness during the switching load fast transition.

The 1EDN7512 features a dual-input design by implementing both inverting (IN- pin) and non-inverting (IN+ pin) configuration in the same device. Either the IN+ or IN- pin can be used to control the state of the driver output. The internal pull-up or pull-down resistors on the input pins ensure that output is held low when the input pins are in floating condition. As a result, the unused input pin must be biased properly to ensure that driver output is enabled for normal operation. Table 1 is the device logic truth table.

Table 1: the 1EDN7512 Device Logic.

IN+	IN-	OUT
L	L	L
H	H	L
H	L	H
H	H	L
Floating	Any	L
Any	Floating	L

### VDD Power Supply

The 1EDN7512 operates under a supply voltage range between 4.5V to 24V. For the best high-speed circuit performance, two VDD bypass capacitors in parallel are recommended to prevent noise problems on supply VDD. A 0.1- $\mu$ F surface mount ceramic capacitor must be located as close as possible to the VDD to GND pins of the 1EDN7512. In addition, a larger capacitor (such as 1 $\mu$ F or 10 $\mu$ F) with relatively low ESR must be connected in parallel, in order to help avoid the unexpected VDD supply glitch. The parallel combination of capacitors presents a low impedance characteristic for the expected current levels and switching frequencies in the application.

### Under Voltage Lock Out (UVLO)

The 1EDN7512 Under Voltage Lock Out (UVLO) rising threshold is typically 4.2 V with 300-mV typical hysteresis. When VDD is rising and the level is still below UVLO threshold, this circuit holds the output low regardless of the status of the inputs. The hysteresis prevents output bouncing when low VDD supply voltages have noise impact from the power supply. The capability to operate at low power supply voltage below 5 V is especially suited for driving wide band gap power device like GaN. For example, during power up, the driver output remains low until the VDD voltage reaches the UVLO threshold. The magnitude of the OUT signal rises with VDD till steady state VDD reached.

The non-inverting operation in Figure 9 shows that the output remains low till the UVLO threshold reached, and then the output is in-phase with the input.



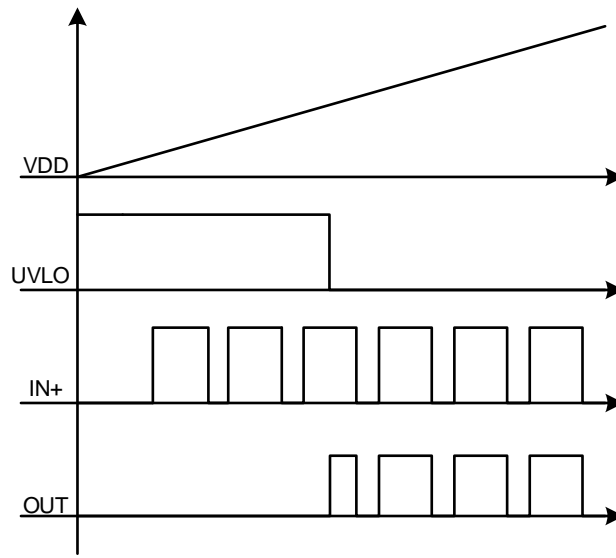

Figure 9. 1EDN7512 Output Vs VDD

### Input Stage

The input 1EDN7512 is compatible on TTL logic that is independent of the VDD supply voltage. With typically high threshold = 2.1 V and typically low threshold = 1.0 V, the logic level thresholds are conveniently driven by PWM control signals derived from 3.3-V and 5-V digital power-controller devices. Wider hysteresis offers enhanced noise immunity compared to traditional TTL logic implementation, where the hysteresis is typically less than 0.5 V. UCC27517 also features tight control of the input threshold voltage that ensures stable operation across temperature. The low input capacitance on the input pins increases switching speed and reduces the propagation delay.

The 1EDN7512 features a dual-input configuration with two input pins available to control the state of the output. The user has the flexibility to configure the device by using either a non-inverting input pin (IN+) or an inverting input pin (IN-). The state of the output pin depends on the bias on both the IN+ and IN- pins. Refer to the input/output logic truth table (Table 1) and the Typical Application Diagrams Figure 11. When any of the input pin is in a floating condition, the driver output is held low state to guarantee the system robustness. There is a 500kOhm ground pull-down resistor on IN+ pin and a 400kOhm VDD pull-up resistor on IN- pin. To achieve the proper output, the IN+ and IN- pin must be properly biased.

1. To configure the 1EDN7512 as a non-inverting driver, apply the PWM input signal on IN+ pin and bias the IN- pin with ground or VDD, where the IN- pin can be used as an enable pin.
2. To configure the 1EDN7512 as an inverting driver, apply the PWM input signal on IN- pin and bias the IN+ pin can be used as an enable pin, where the IN+ can be used as an enable pin.

### Output Stage

The 1EDN7512 output stage features the pull up structure with P-type MOSFET PM1 and N-type MOSFET NM1 in parallel, as shown in Figure 10. PM1 provides the pull up capability when OUT approaches VDD and the NM1 holds off state, which guarantees the driver output is up to VDD rail. The measurable on-resistance  $R_{OH}$  in steady state is the conduction resistance of PM1. NM1 provides a narrow instant peak sourcing current up to 4A to eliminate the turn on time and delay. During the output turn on transition, the equivalent hybrid pull on transient resistance is  $1.5 \times R_{OL}$ , which is much lower than the  $R_{OH}$ .

The N-type MOSFET NM2 composes the output stage pull down structure; the  $R_{OL}$  is the DC measurement and represents the pull down impedance. The output stage of 1EDN7512 provides rail-to-rail operation, and is able to supply 4A sourcing and 4A sinking current. The presence of the MOSFET-body diodes also offers low impedance path to damp overshoots and undershoots. The outputs of the dual channel drivers are designed to withstand 500-

mA reverse current without either damaging the device or causing the logic malfunction.

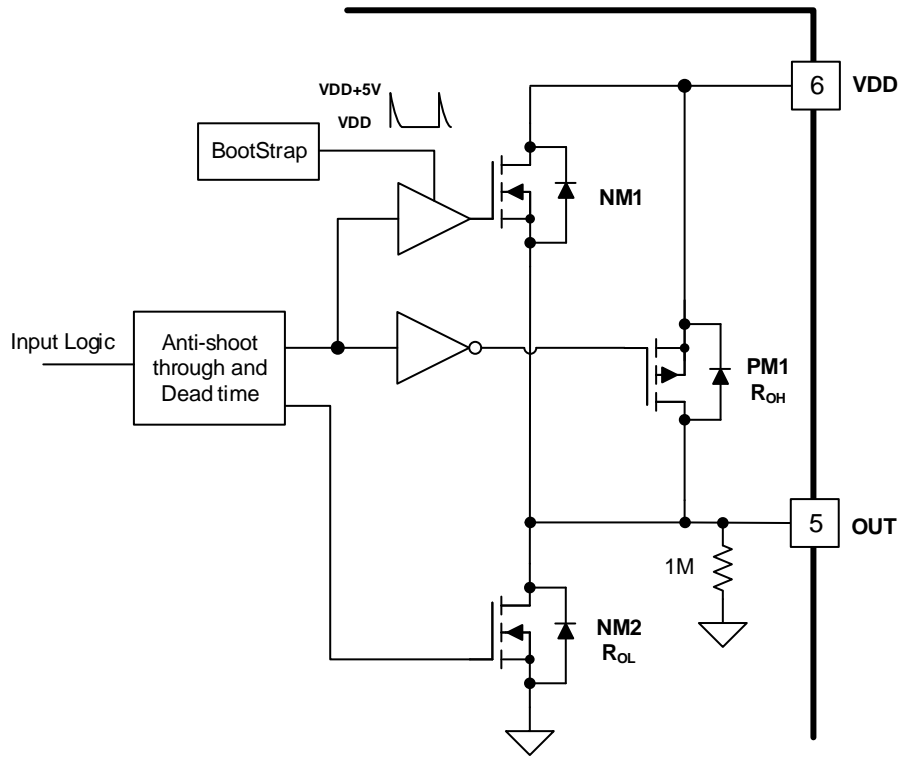

Figure 10. 1EDN7512 Output Stage

**Thermal Shutdown**

Once the junction temperature in the 1EDN7512 exceeds 170° C, the thermal sensing circuit stops switching until the junction temperature falling below 145° C, and the device restarts. Thermal shutdown prevents the damage on device during excessive heat and power dissipation condition.

## APPLICATION INFORMATION

### Typical Application

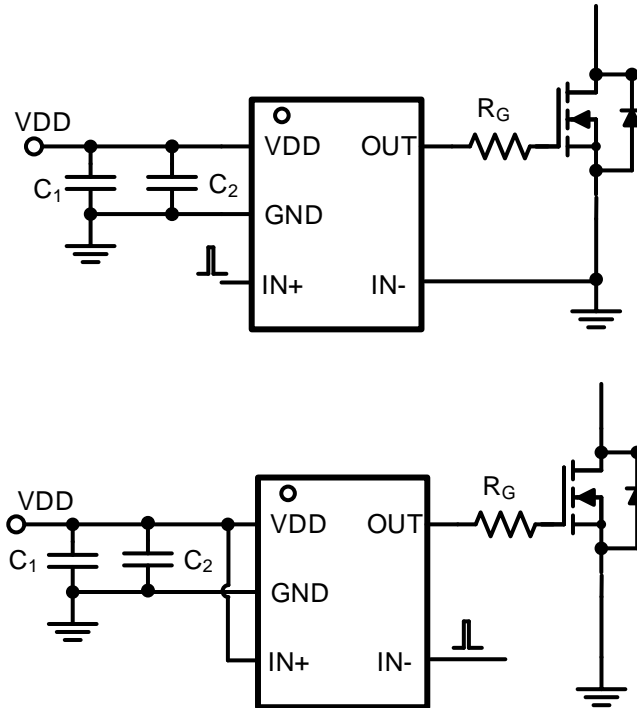

Figure 11. Single Channel Driver Non-Inverting and Inverting Application

### Driver Power Dissipation

Generally, the power dissipated in the 1EDN7512 depends on the gate charge required of the power device ( $Q_g$ ), switching frequency, and use of external gate resistors. The 1EDN7512 features very low quiescent currents and internal logic to eliminate any shoot-through in the output driver stage, their effect on the power dissipation within the gate driver is negligible.

For the pure capacitive load, the power loss of 1EDN7512 is:

$$P_G = C_{Load} * V_{DD}^2 * f_{SW} \quad (1)$$

Where

- $V_{DD}$  is supply voltage
- $C_{Load}$  is the output capacitance
- $f_{SW}$  is the switching frequency

For the switching load of power MOSFET, the power loss of the driver is shown in equation (1), where charging a capacitor is determined by using the equivalence  $Q_g = C_{LOAD}V_{DD}$ . The gate charge includes the effect of the input capacitance plus the added charge needed to swing the drain voltage of the power device as it switches between the ON and OFF states. Manufacturers provide specifications with the typical and maximum gate charge, in nC, to switch the device under specified conditions.

$$P_G = Q_g * V_{DD} * f_{SW} \tag{2}$$

Where

- $Q_g$  is the gate charge of the power device
- $f_{sw}$  is the switching frequency
- $V_{DD}$  is the supply voltage

If  $R_G$  applied between driver and gate of power device to slow down the power device transition, the power dissipation of the driver shows as below:

$$P_G = \frac{1}{2} * Q_g * V_{DD} * f_{SW} * \left( \frac{R_{OL}}{R_{OL} + R_G} + \frac{R_{OH}}{R_{OH} + R_G} \right) \tag{3}$$

Where

- $R_{OH}$  is the equivalent pull up resistance of 1EDN7512
- $R_{OL}$  is the pull down resistance of 1EDN7512
- $R_G$  is the gate resistance between driver output and gate of power device.

### Application Waveforms

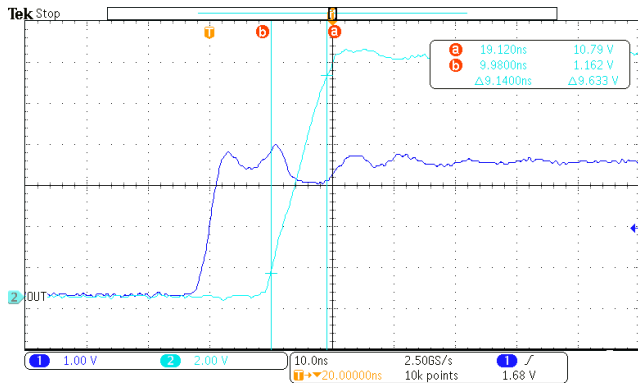

Figure 12. IN+ Switching ON

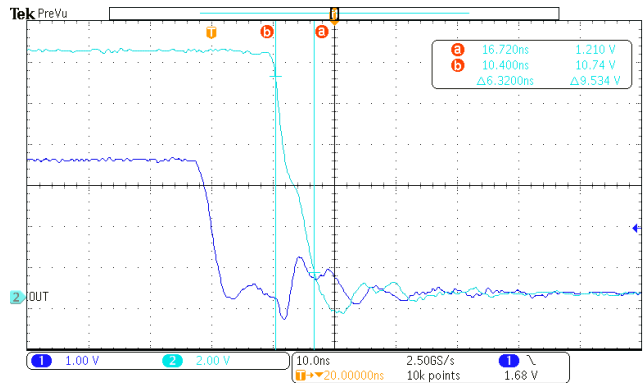

Figure 13. IN+ Switching OFF

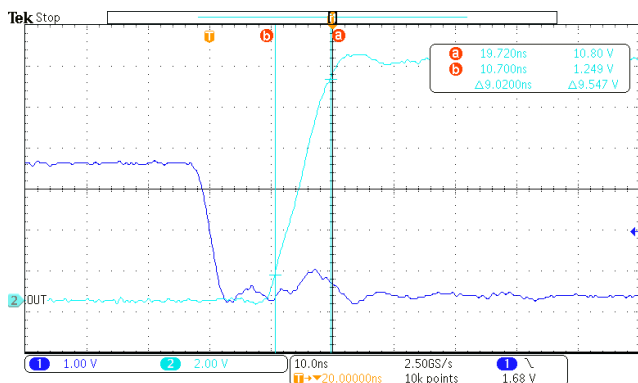

Figure 14. IN- Switching ON

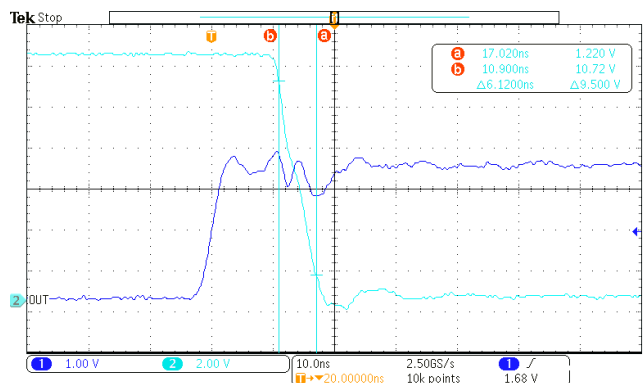

Figure 15. IN- Switching OFF

## Layout Guideline

The 1EDN7512 provides the 4A output driving current and features very short rising and falling time at the power device gate. The high  $di/dt$  causes driver output unexpected ringing when the driver output loop is not optimized. The regulator could suffer from malfunction and EMI noise if the power device gate has serious ringing. Below are the layout recommendations with using 1EDN7512 and Figure 16 is the layout example.

Put the 1EDN7512 as close as possible to the power device and minimize the gate driving loop including the driver output and power device gate. The power supply decoupling capacitors needs to be close to the VDD pin and GND pin to reduce the supply ripple.

Star-point grounding is recommended to minimize noise coupling from one current loop to the other. The GND of the driver connects to the other circuit node such as source of power MOSFET or ground of PWM controller at single point. The connected paths must be as short as possible to reduce parasitic inductance. A ground plane provides noise shielding and thermal dissipation as well.

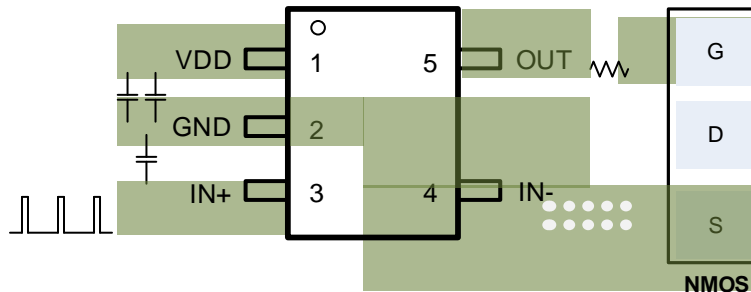

Figure 16. 1EDN7512 PCB Layout Example

## Thermal Considerations

The maximum IC junction temperature should be restricted to 170°C under normal operating conditions. Calculate the maximum allowable dissipation,  $P_{D(max)}$ , and keep the actual power dissipation less than or equal to  $P_{D(max)}$ . The maximum-power-dissipation limit is determined using Equation (4).

$$P_{D(MAX)} = \frac{150 - T_A}{R_{\theta JA}} \quad (4)$$

where

- $T_A$  is the maximum ambient temperature for the application.
- $R_{\theta JA}$  is the junction-to-ambient thermal resistance given in the Thermal Information table.

The real junction-to-ambient thermal resistance  $R_{\theta JA}$  of the package greatly depends on the PCB type, layout, and environmental factor. Soldering the ground pin to a large ground plate enhance the thermal performance. Using more vias connects the ground plate on the top layer and bottom layer around the IC without solder mask also improves the thermal capability.

## PACKAGE INFORMATION

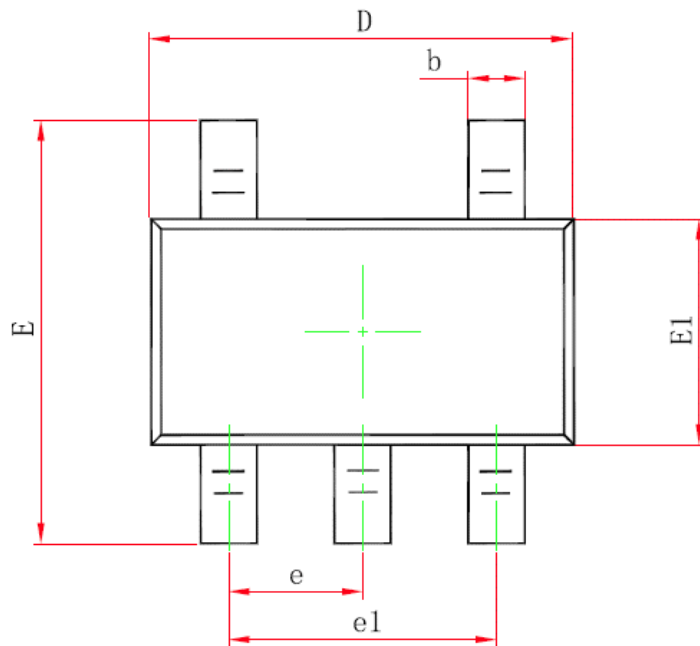

TOP VIEW

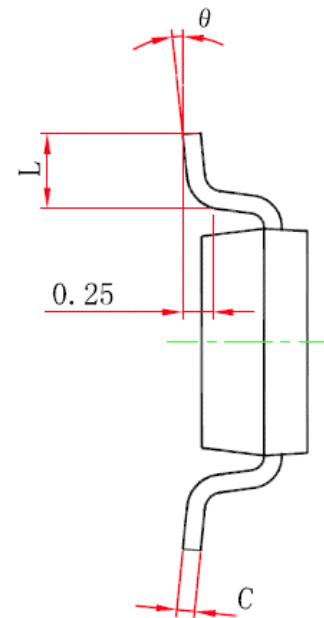

BOTTOM VIEW

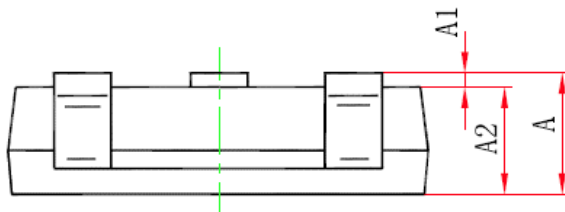

SIDE VIEW

SYMBOL	Unit: Millimeter		
	MIN	TYP	MAX
A	---	---	0.9
A1	0.02	---	0.09
A2	0.7	---	0.8
b	0.35	---	0.5
c	0.08	---	0.2
D	2.82		3.02
E	2.65		2.95
E1	1.6		1.7
e	0.95 (BSC)		
e1	1.90 (BSC)		
L	0.3		0.6
e	0°		8°

### NOTE:

1. Drawing proposed to be made a JEDEC package outline MO-220 variation.
2. Drawing not to scale.
3. All linear dimensions are in millimeters.
4. Thermal pad shall be soldered on the board.
5. Dimensions of exposed pad on bottom of package do not include mold flash.
6. Contact PCB board fabrication for minimum solder mask web tolerances between the pins.

### TAPE AND REEL INFORMATION

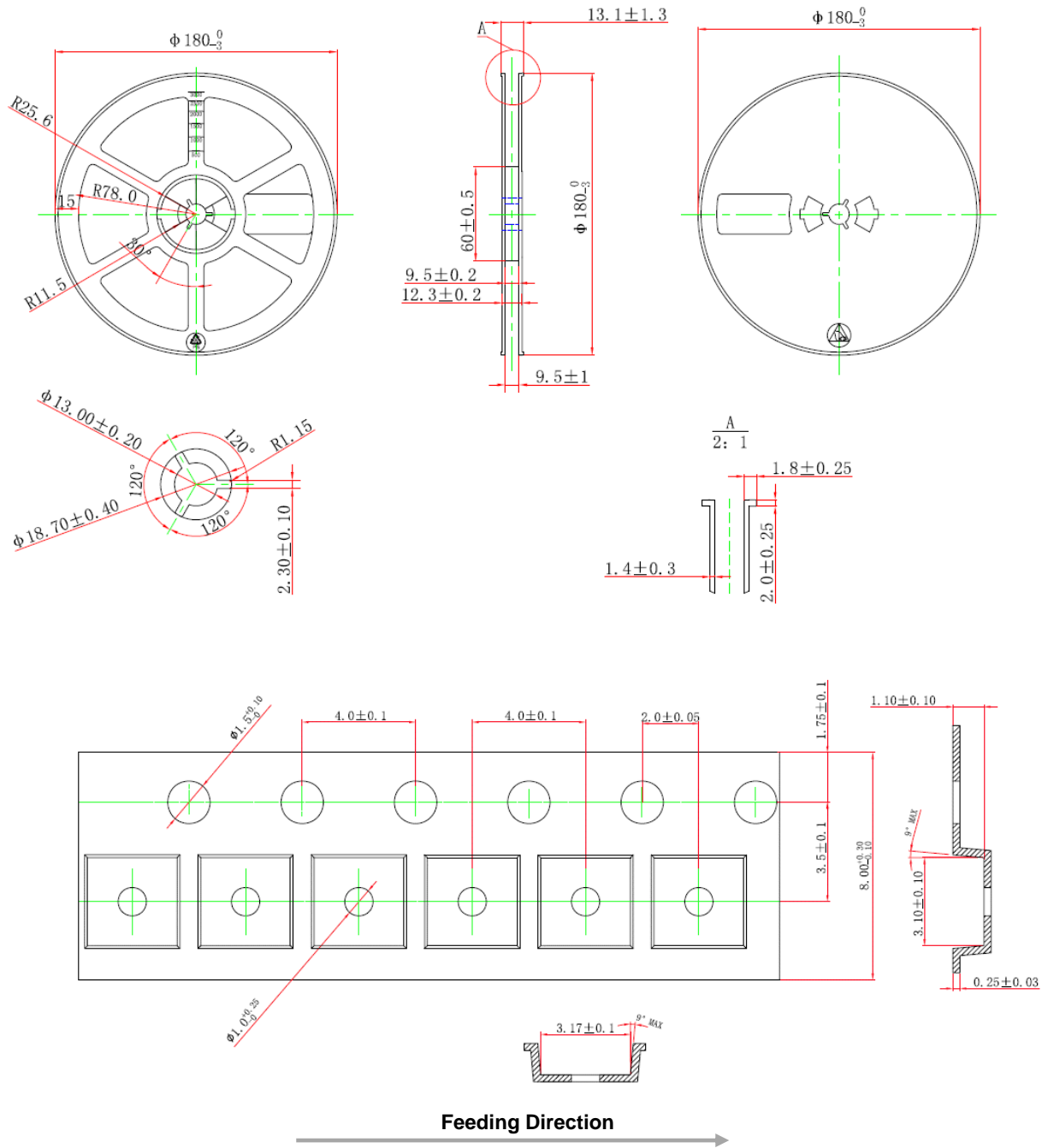

## TYPICAL APPLICATION

1END7512 Typical Application

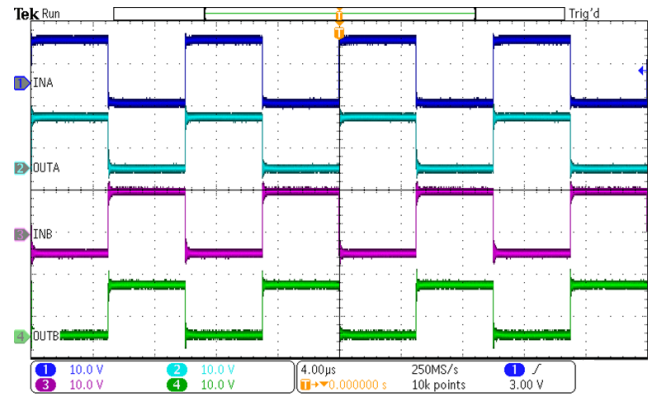
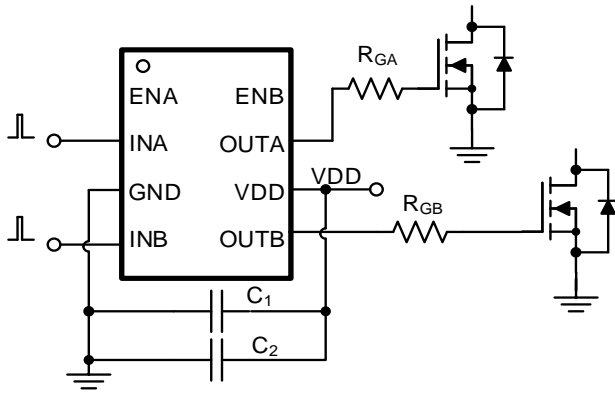

## RELATED PARTS

PART NUMBERS	DESCRIPTION	COMMENTS
1END7512	Up to 24V Supply, 4-A Dual Channel High Speed Low Side Driver	<ul style="list-style-type: none"> <li>Stackable Output Application</li> <li>-5V Input Capability</li> </ul>