



Specification

Document No.: OSK-SPC- SKC6812RGBX-XX

Product No.: SKC6812RGBX-XX

Description: 5.0X4.9x1.6mm 0.25W intelligent external control surface mount R, G, B, W/Y /Afour-in-one SMD LED (MSL: 5a)

Rev. No.: A/4

Date: 2023-05-11

Customer approval			Opsco approval		
Approval	Review	Confirmation	Approval	Review	Confirmation
			朱更生	周凯	刘峰
<input type="checkbox"/> Qualified <input type="checkbox"/> Disqualified Stamp			Stamp		



* Before using our products, please search our official website to check the version of specifications. The version of product specifications is updated. We are sorry to fail to inform you in time. Please refer to the latest information on the official website.

* The copyright and final interpretation of the product belong to Dongguan Occidental Optoelectronics Technology Co., Ltd. If you have special specifications, please contact our engineering staff;

* Tel:0512-57330115/15951130700

Email:(xs.shan@opscoled.com)



CONTENTS

1、Product overview.....	4
2、Main Application Field.....	4
3、Description.....	4
4、Mechanical Dimensions.....	4
5、PIN configuration.....	5
6、Recommended dimensions for PCB products.....	5
7、General description of product naming.....	5
8、Electrical parameters.....	6
9、Electrical/Optical Characteristics.....	6
10、The IC electrical parameters.....	6
11、Switching characteristics.....	7
12、The data transmission time	7
13、Timing waveform.....	8
14、The method of data transmission.....	8
15、The data structure of 32 bit.....	9
16、The typical application circuit.....	9
17、Wavelength classification specification.....	9
18、White Color Temperature Ranks.....	10-12
19、Standard LED Performance Graph.....	13
20、Packaging Standard.....	14
21、Reliability Test.....	15

1. Product Overview :

SKC6812RGBX-XX is a smart LED control circuit and light emitting circuit in one controlled LED source, which has the shape of a 5050 LED chip. Each lighting element is a pixel, and the intensities of the pixels are contained within the intelligent digital interface input. The output is driven by patented PWM technology, which effectively guarantees high consistency of the color of the pixels. The control circuit consists of a signal shaping amplification circuit, a built-in constant current circuit, and a high precision RC oscillator.

The data protocol being used is unipolar RZ communication mode. The 32-bit data is transmitted from the controller to DIN of the first element, and if it is accepted it is extracted pixel to pixel. After an internal data latch, the remaining data is passed through the internal amplification circuit and sent out on the DO port to the remaining pixels. The pixel is reset after the end of DIN. Using automatic shaping forwarding technology makes the number of cascaded pixels without signal transmission only limited by signal transmission speed.

The LED has a low driving voltage (which allows for environmental protection and energy saving), high brightness, scattering angle, good consistency, low power, and long life. The control circuit is integrated in the LED above.

2. Main Application Field:

- Full color LED string light, LED full color module, LED super hard and soft lights, LED guardrail tube, LED appearance / scene lighting
- LED point light, LED pixel screen, LED shaped screen, a variety of electronic products, electrical equipment etc..

3. Description:

- Top SMD internal integrated high quality external control line serial cascade constant current IC;
- control circuit and the chip in SMD 5050 components, to form a complete control of pixel, color mixing uniformity and consistency;
- built-in data shaping circuit, a pixel signal is received after wave shaping and output waveform distortion will not guarantee a line;
- The built-in power on reset and reset circuit, the power does not work;
- gray level adjusting circuit (256 level gray scale adjustable);
- red drive special treatment, color balance;
- line data transmission;
- plastic forward strengthening technology, the transmission distance between two points over 10M;
- Using a typical data transmission frequency of 800 Kbps, when the refresh rate of 30 frames per sec

4. Mechanical Dimensions:

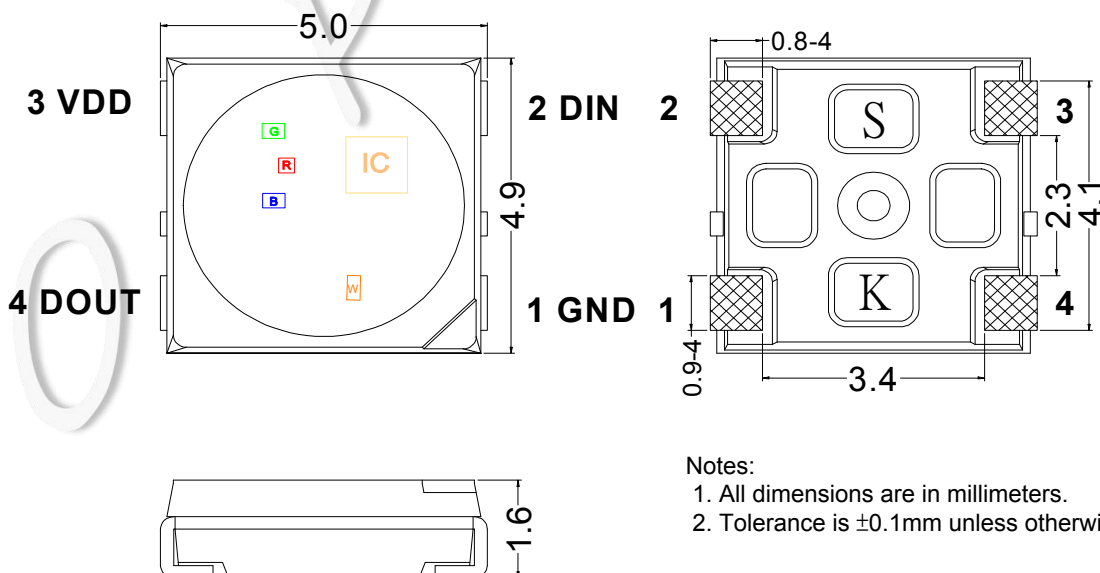

5. PIN configuration

NO.	Symbol	Function description
1	GND	Ground
2	DIN	Control data signal input
3	VDD	Power supply LED
4	DOUT	Control data signal output

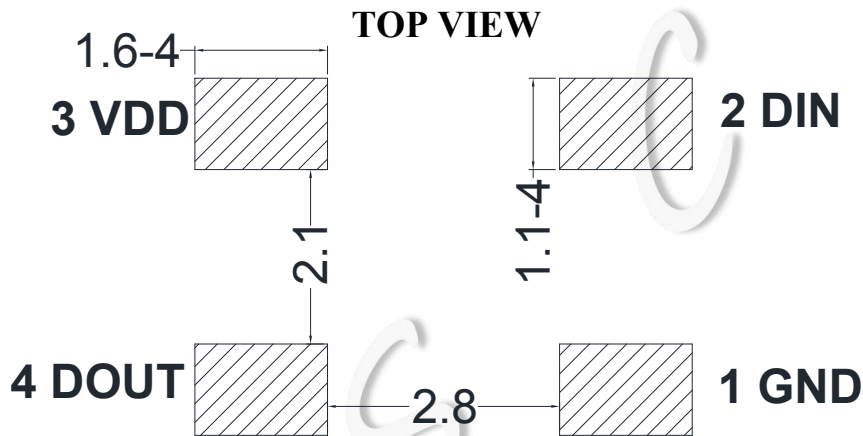
6. Recommended dimensions for PCB products

7. General description of product naming.

SKC 6812RGBX-XX

①

②

③

①	②	③
Series	ICseries and current code	Color zone
The default is RGB chip IC integrated together	Refers to the 68 series IC R/G/B8MA current W:16.5MA current version X (W) : White light X (Y) : Yellow585-595NM X (A) : Indicates amber light	XX: BW Blue White 5500-10000K NW Natural White 3800-4500K WS Warm Sunlight 2700-3200K

8. Electrical Parameters (Ta=25°C, VSS=0V) :

Parameter	Symbol	Range	Unit
Power supply voltage	VDD	+3.7~+5.5	V
Logic input voltage	V _{IN}	-0.5~VDD+0.5	V
Working temperature	T _{opt}	-40~+85	°C
Storage temperature	T _{stg}	-40~+85	°C
ESD pressure(HBM)	V _{ESD}	2K	V
ESD pressure(DM)	V _{ESD}	200	V

9. Electrical/Optical Characteristics:

Color	SKC6812RGBX-XX		
	Dominate avelength(nm)	Color temperature	Luminance(mcd)
Red	615-625	/	200-385
Green	515-530	/	580-1050
Blue	460-470	/	120-240
Yellow	585-595	/	385-697.5
WHITE	/	2700-10000	1800-2525

10. The IC electrical parameters (unless otherwise specified, TA=-20 ~ +70 °C, VDD=4.5 ~ 5.5V, VSS=0V):

Parmeter	Symbol	Min	Typical	Max	Unit	Test conditions
The chip supply voltage	VDD	---	5.2	---	V	---
The signal input flip threshold	V _{IH}	0.7*VDD	---	---	V	VDD=5.0V
	V _{IL}	---	---	0.3*VDD	V	
The frequency of PWM	FPWM	---	4.0	---	KHZ	---
Static power consumption	IDD	---	0.29	---	mA	---

11. Switching characteristics(Ta=25 °C):

parameter	Symbol	Min	Typical value	Max	Unit	Test conditions
Chip operating voltage	VDD	3.5	-	5.5	V	-
Chip operating voltage	IDD	-	0.29	-	mA	VDD=5V , IOUT "OFF"
Input signal threshold voltage	VIH	2.7	-	-	V	VDD=5V, Adjust DIN input level
	VIL	-	-	1.8	V	
DOUT Output current	IOH	-	-29	-	mA	High DOUT output, 10 Ω resistor in series
DOUT current	IOL	-	20	-	mA	DOUT output is low, the power supply charges current to DOUT
OUT R/G/B Output current	IOUT	-	8	-	mA	VDD=5V, VDS =1.0V
OUT W Output current		-	16.5	-	mA	VDD=5V, VDS =1.0V
OUT R/G/B Constant current inflection voltage	VDS_S	-	0.6	-	V	IOUT = 8mA
OUTW Constant current inflection voltage		-	0.8	-	V	IOUT = 16.5mA
OUT R/G/B/W Output current change	%VS.VDS	-	0.5	-	%	IOUTR/G/B = 8mA , VDS =1.0~3.0V
		-	0.5	-	%	IOUTW = 16.5mA , VDS =1.0~3.0V
	%VS.VDD	-	0.5	-	%	IOUTR/G/B =8mA , VDD = 4.5~5.5V
		-	0.5	-	%	IOUTW =16.5mA , VDD = 4.5~5.5V
	%VS.TA	-	5.0	-	%	IOUT R/G/B= 8mA , TA= -40~+85°C
-		5.0	-	%	IOUTW = 16.5mA , TA= -40~+85°C	
OUT R/G/B/W Port withstand voltage	BVOUT	-	14	-	V	OUT R / G / B / W port closed, leakage current 1uA

parameter	Symbol	Min	Typical value	Max	Unit	Test conditions
Data transmission speed	fDIN	---	800	---	KHZ	Duty cycle 67% (data 1)
Dout transmission delay (Note 3)	TPLH	---	100	---	ns	The earth load capacitance of the dout port is 30pf, and the signal transmission delay from DIN to dout
	TPHL	---	100	---	ns	
Dout conversion time (Note 4)	TTLH	---	20	---	ns	The earth load capacitance of the dout port is 30pf
	TTHL	---	10	---	ns	
Output R / G / B / W conversion time (Note 5)	Tr	---	152	---	ns	IOUT R / B= 5mA, out R/G/B/W port connected with 200 Ω resistor to VDD in series , The earth load capacitance of the dout port is 30pf
	Tf	---	300	---	ns	

Note 3, note 4 and note 5 are shown in the figure below:

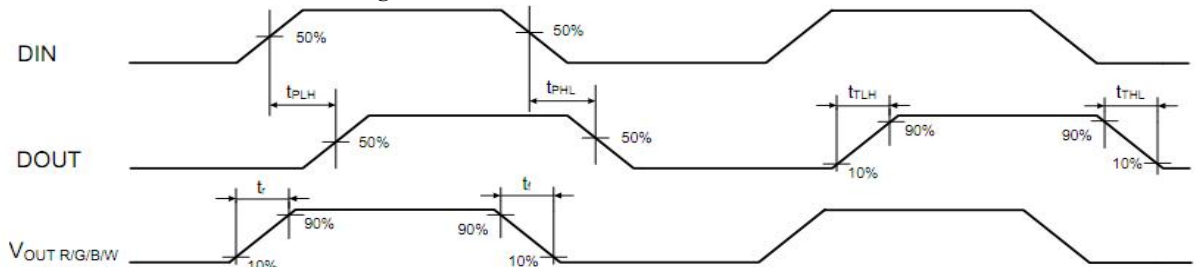

12. The data transmission time :

Name		Min.	Standard value	Max.	Unit
T	Code period	1.20	--	--	μs
T0H	0 code, high level time	0.2	0.3	0.4	μs
T0L	0 code, low level time	0.8	--	--	μs
T1H	1 code, high level time	0.65	0.75	1.0	μs
T1L	1 code, low level time	0.2	--	--	μs
Reset	Reset code, low level time	>200	--	--	μs

1. The protocol uses a unipolar zeroing code. Each symbol must have a low level. Each symbol in this protocol starts with a high level. The high time width determines the "0" or "1" code. .
2. When writing programs, the minimum symbol period is 1.2μs.
3. The high time of "0" code and "1" code should be in accordance with the stipulated range in the above table. The low time requirement of "0" code and "1" code is less than 20μs.

13. Timing waveform:

Input code:

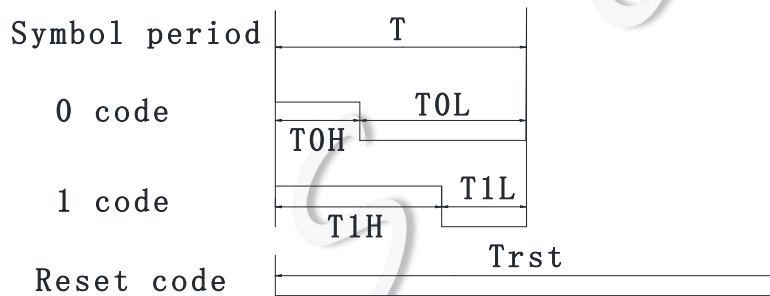

Connection mode:

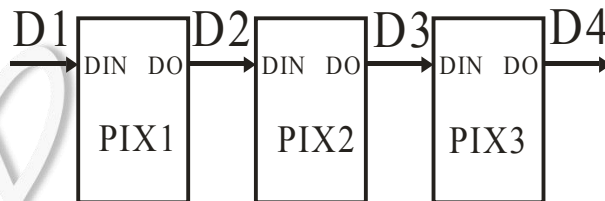

14. The method of data transmission:

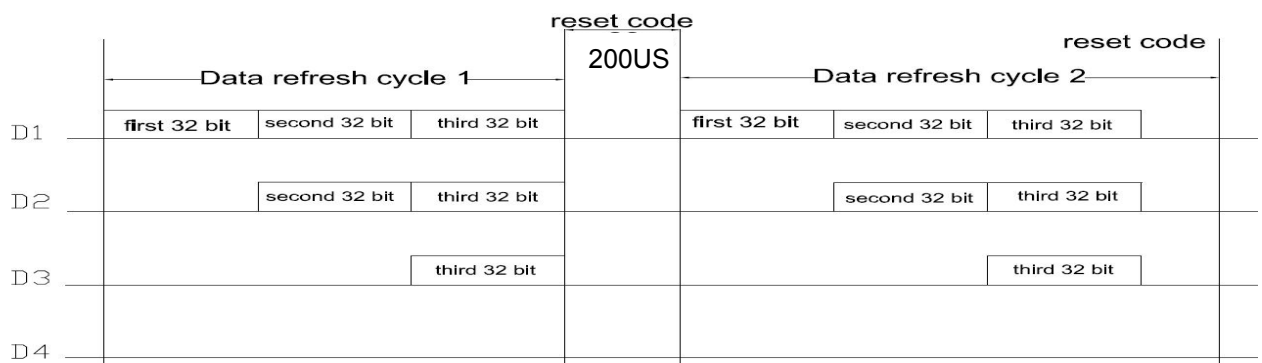

Note: the D1 sends data for MCU, D2, D3, D4 for data forwarding automatic shaping cascade circuit.

15. The data structure of 32bit:

G7	G6	G5	G4	G3	G2	G1	G0	R7	R6	R5	R4
R3	R2	R1	R0	B7	B6	B5	B4	B3	B2	B1	B0
W/Y/A7	W/Y/A6	W/Y/A5	W/Y/A4	W/Y/A3	W/Y/A2	W/Y/A1	W/Y/A0				

Note: high starting, in order to send data (G7 - G6 - W/Y/A0)

16. The typical application circuit:

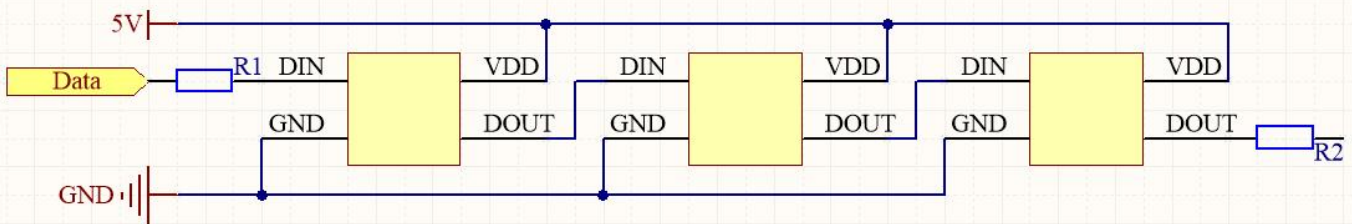

In the practical application circuit, the signal input and output pins of the IC signal input and output pins should be connected to the signal input and output terminals. In addition, in order to make the IC chip more stable, even the capacitance between beads is essential back;

Application: used for soft lamp strip or hard light, lamp beads transmission distance is short, suggested in signal in time the clock line input and output end of each connected in series protection resistors, $R1=R2$ of about 500 ohms.

Application: for module or general special-shaped products, lamp beads transmission distance is long, because of different wire and transmission distance, in the signal in time clock at both ends of the line on grounding protection resistance will be slightly different; to the actual use of fixed;

17. Wavelength classification specification of yellow, red, green and blue

Name	Code	λ d MIN (nm)	λ d MAX (nm)
YELLOW	YL1	585	590
	YL2	590	595
RED	HR1	615	620
	HR2	620	625
BLUE	BL5	460	465
	BL6	465	470
GREEN	PG2	515	520
	PG3	520	525
	PG4	525	530

18. White Color Temperature Ranks & CIE Color Rank (Refer to CIE 1931 chromaticity diagram)

CIE chromaticity coordinates (ANSI Cool White)

Name	X1	Y1	X2	Y2	X3	Y3	X4	Y4
BW-A	0.2928	0.2822	0.2802	0.2895	0.2885	0.3007	0.3011	0.2934
BW-B	0.3011	0.2934	0.2885	0.3007	0.302	0.3189	0.3147	0.3116
BW-C	0.3147	0.3116	0.302	0.3189	0.3186	0.3412	0.3313	0.3339
BW-D	0.3313	0.3339	0.3186	0.3412	0.3326	0.36	0.3449	0.3522

ANSI Blue White Color bin structures

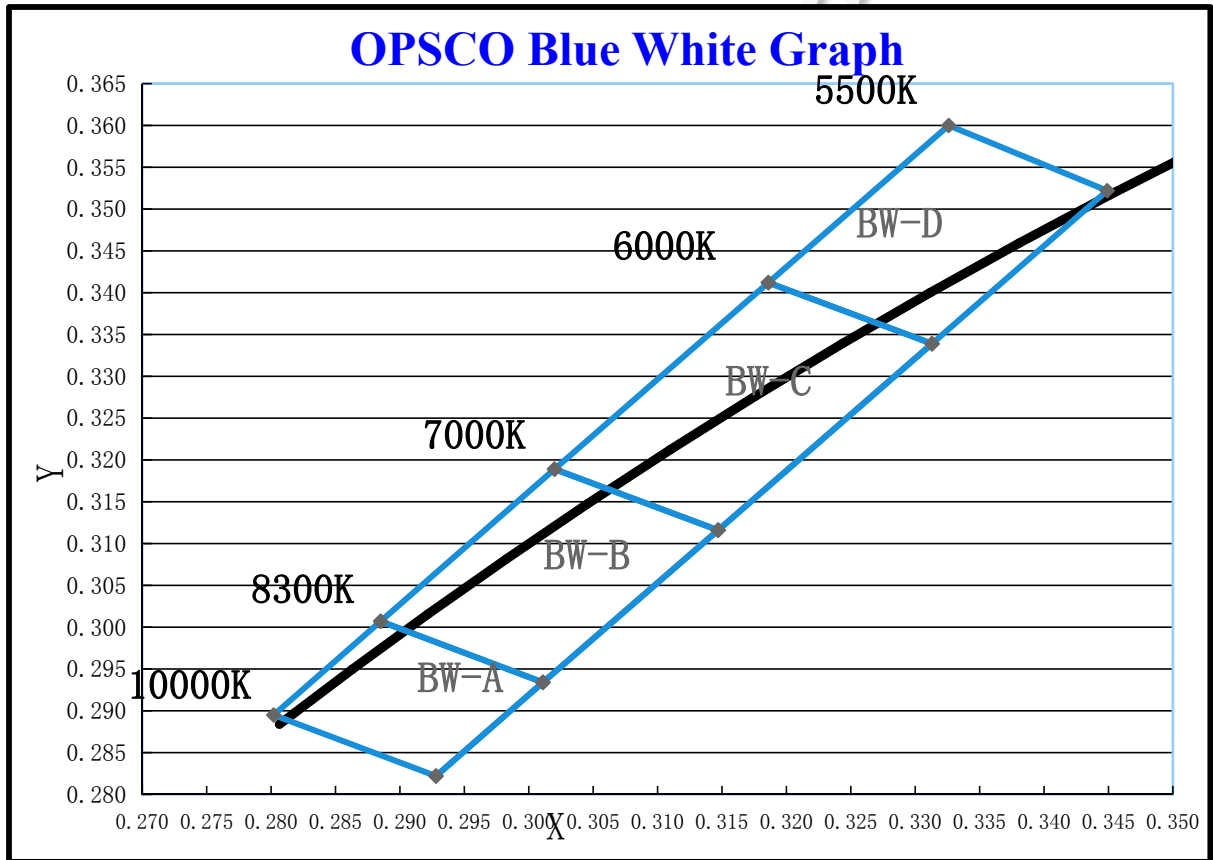



CIE chromaticity coordinates (ANSI Natural white)

Name	X1	Y1	X2	Y2	X3	Y3	X4	Y4
NA-A	0.3651	0.3524	0.3531	0.36	0.3602	0.3679	0.3722	0.3603
NB-A	0.3722	0.3603	0.3602	0.3679	0.3659	0.3743	0.3779	0.3667
NC-A	0.3779	0.3667	0.3659	0.3743	0.3716	0.3807	0.3836	0.373
ND-A	0.3836	0.373	0.3716	0.3807	0.3773	0.3871	0.3893	0.3794
NE-A	0.3893	0.3794	0.3773	0.3871	0.3844	0.3949	0.3963	0.3873

ANSI Natural White Color bin structures

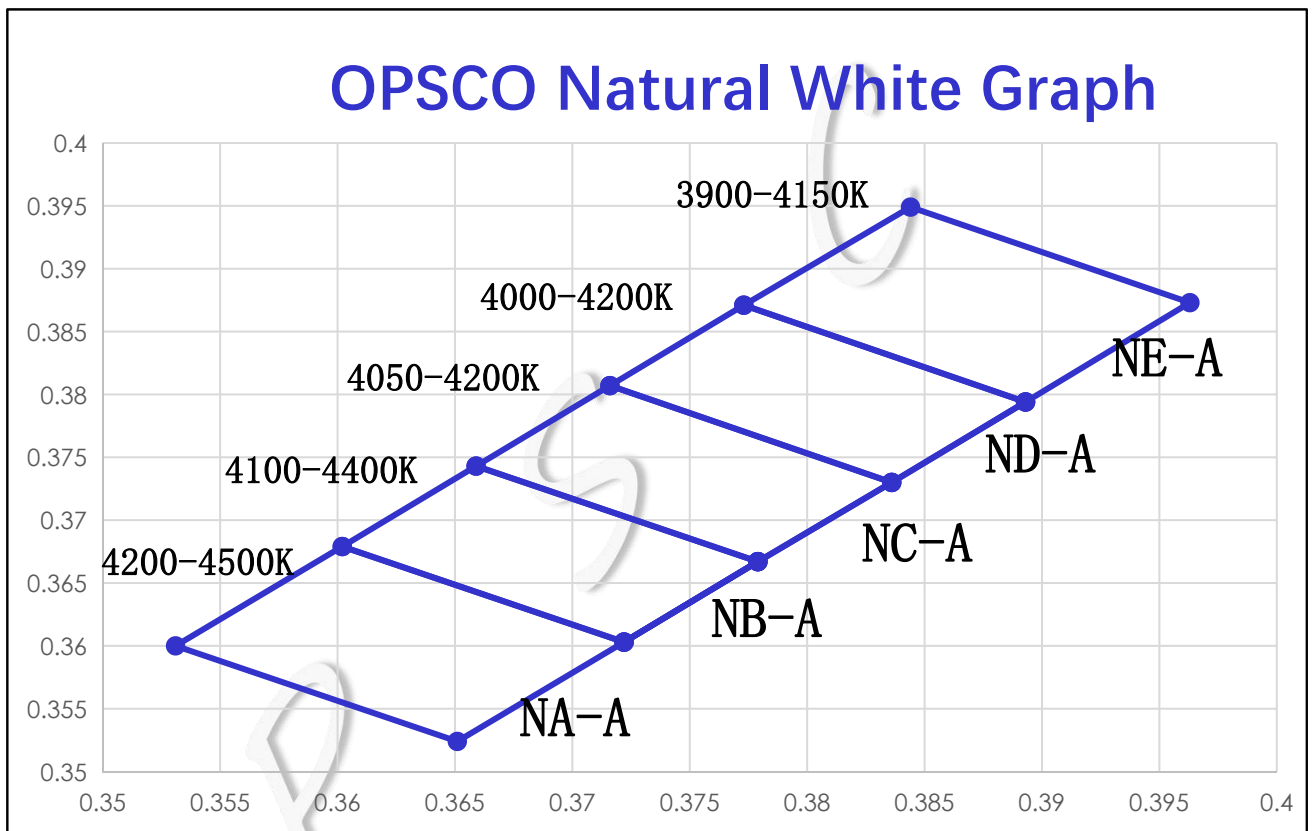

CIE chromaticity coordinates (ANSI Warm White)

名称	X1	Y1	X2	Y2	X3	Y3	X4	Y4
K1-A	0.4344	0.4032	0.4221	0.3984	0.4147	0.3814	0.426	0.3853
K2-A	0.443	0.4212	0.4299	0.4165	0.4221	0.3984	0.4344	0.4032
K3-A	0.4562	0.426	0.443	0.4212	0.4344	0.4032	0.4465	0.4071
K4-A	0.4465	0.4071	0.4344	0.4032	0.426	0.3853	0.4373	0.3893
L1-A	0.4586	0.4103	0.4465	0.4071	0.4373	0.3893	0.4483	0.3918
L2-A	0.4687	0.4289	0.4562	0.426	0.4465	0.4071	0.4586	0.4103

ANSI Warm White Color bin structures

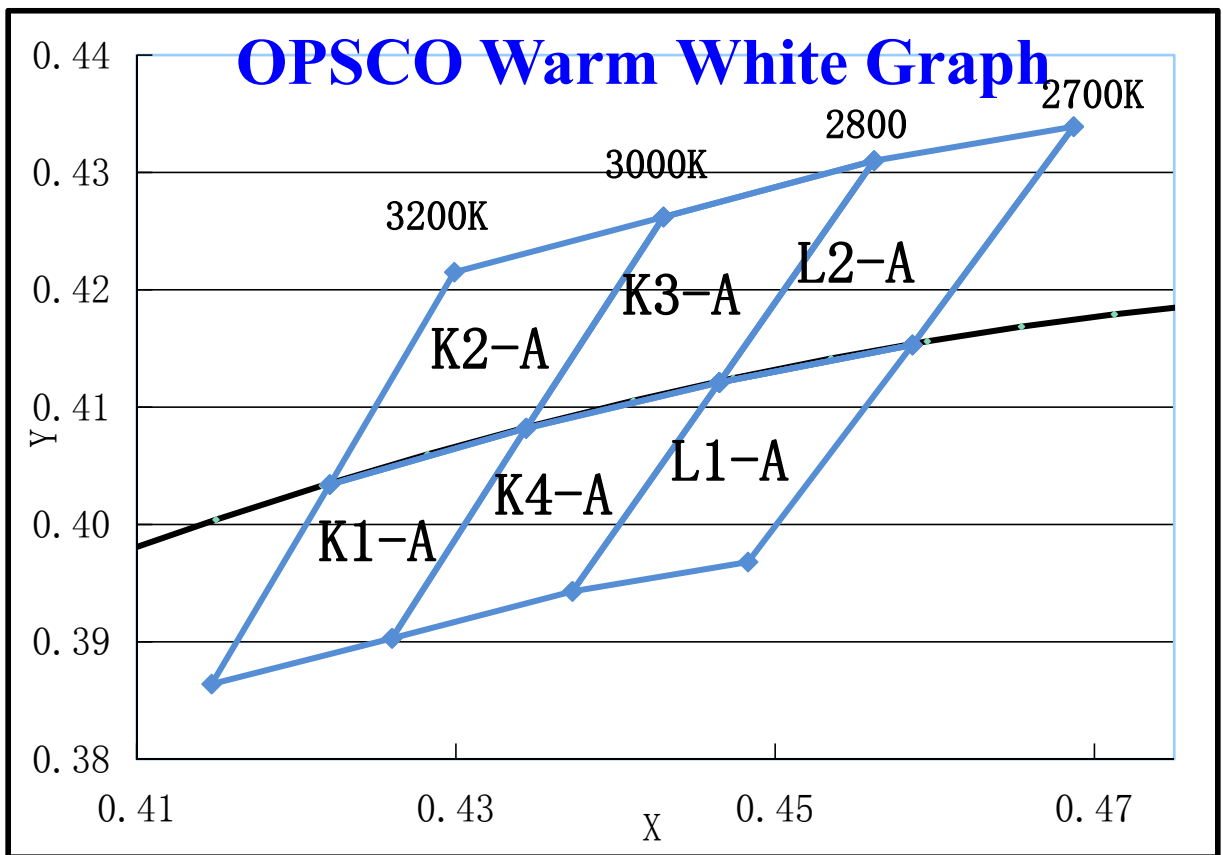

19. Standard LED Performance Graph:

Thermal Pad Temperature vs. Relative Light Output

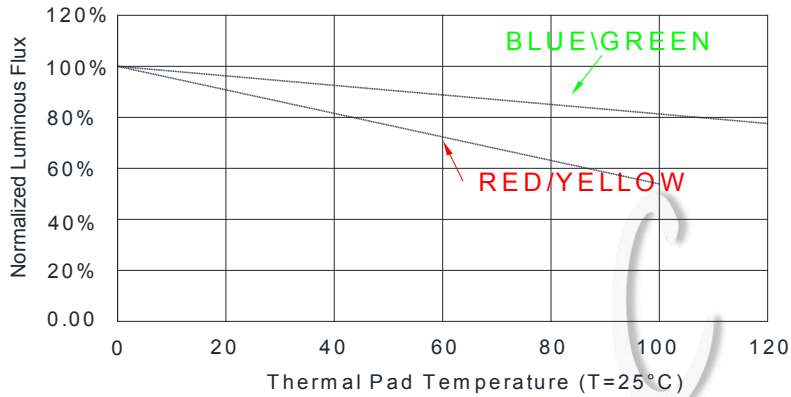

Wavelength Characteristics

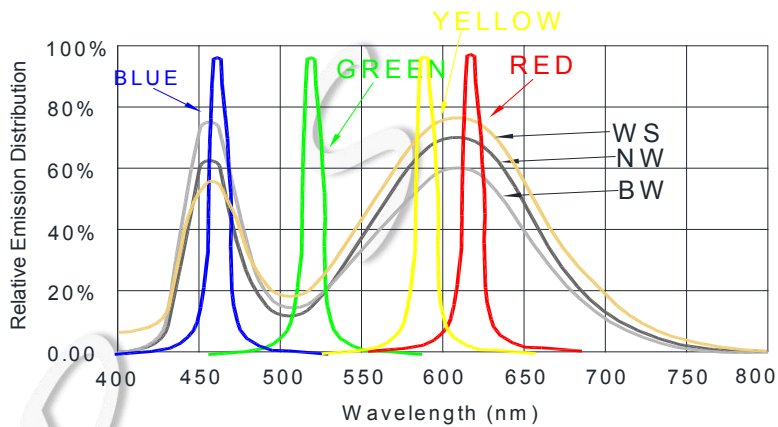

Typical Radiation Pattern 120°

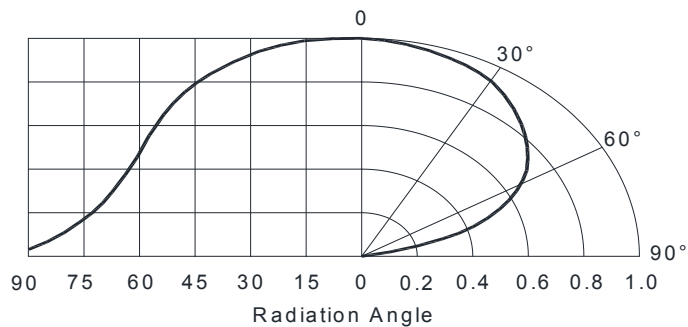

20. Packaging Standard:

SKC6812RGBW-WS

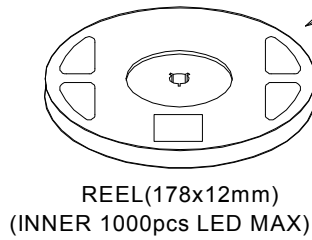
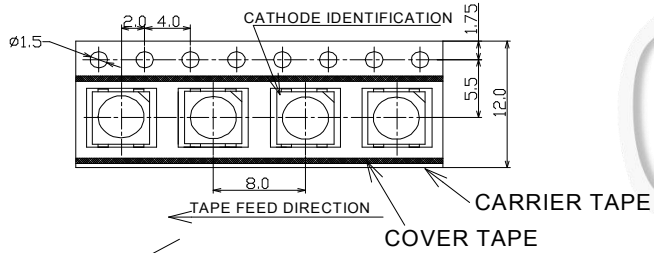

ESD POLYETHYLENE BAG

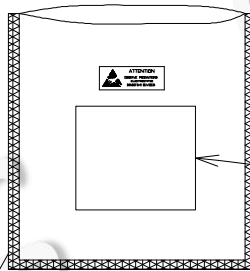

LABEL SKETCHING

CARDBOARD (INNER 40 BAG MAX.)

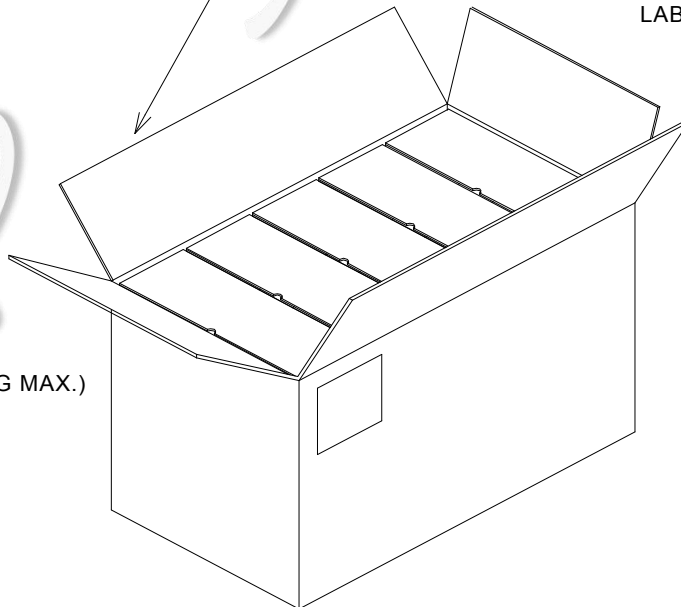

The reel pack is applied in SMD LED. The LEDs are packed in cardboard boxes after packaging in normal or anti-electrostatic bags. cardboard boxes will be used to protect the LEDs from mechanical shocks during transportation. The boxes are not water resistant and therefore must be kept away from water and moisture.

21. Reliability Test :

NO.	Test item	Test Conditions	Reference	Criterion
1	Thermal Shock	$100 \pm 5^{\circ} \text{C} \sim -40^{\circ} \text{C} \pm 5^{\circ} \text{C}$ 30min~30min 100 cycles	MIL-STD-202G	0/22
2	High Temperature Storage	Ta= +100°C 1000hrs	JEITA ED-4701 200 201	0/22
3	Low Temperature Storage	Ta= -40°C 1000hrs	JEITA ED-4701 200 202	0/22
4	High Temperature High Humidity Storage	Ta=60°C RH=90% 1000hrs	JEITA ED-4701 100 103	0/22
5	Temperature Cycle	-40°C~25°C~100°C~25°C 30min~5min~30min~5min 100 cycles	JEITA ED-4701 100 105	0/22
6	Resistance to Soldering Heat	Tsld = 260° C, 10sec. 2 times	JEITA ED-4701 300 301	0/22
7	Room temp Life Test	25° C, IF: Typical current , 1000hrs	JESD22-A 108D	0/22

Criteria for Judging the Damage:

Item	Symbol	Test Condition	Limit	
			Min	Max
Luminous Intensity	IV	DC=5V, Typical current	Init. Value*0.7	---
Resistance to Soldering Heat	---	DC=5V, Typical current	No dead lights or obvious damage	