

SPECIFICATIONS

Current Rating:1.0 Amps  
 Withstanding Voltage:AC 500V  
 Insulation Resistance:1000MΩ Min  
 Contact Resistance:20mΩ Max  
 Operation Temperature:-40° to+105°  
 Insrlator Material:Polyester(UL94V-0)  
 Contact Material:Brass  
 Standard:PA6T  
 Contact Plating:Gold Flash  
 Max.Processing Temp: 240°C for30-60seconds  
 (260°C for5seconds)

P/N	PIN	DIM.A	DIM.B
PH1.27-01-01PZS	1	0.00	1.27
PH1.27-01-02PZS	2	1.27	2.54
PH1.27-01-03PZS	3	2.54	3.81
PH1.27-01-04PZS	4	3.81	5.08
PH1.27-01-05PZS	5	5.08	6.35
PH1.27-01-06PZS	6	6.35	7.62
PH1.27-01-07PZS	7	7.62	8.89
PH1.27-01-08PZS	8	8.89	10.16
PH1.27-01-09PZS	9	10.16	11.43
.....	.....	.....	.....
PH1.27-01-50PZS	50	(PIN-1)x1.27	(PIN)x1.27

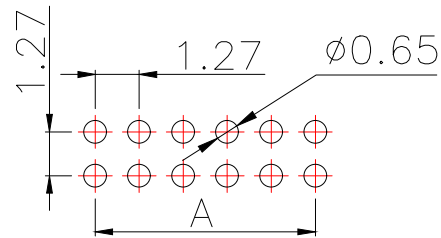
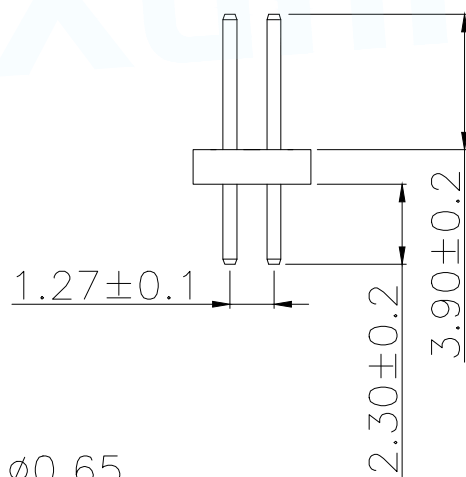
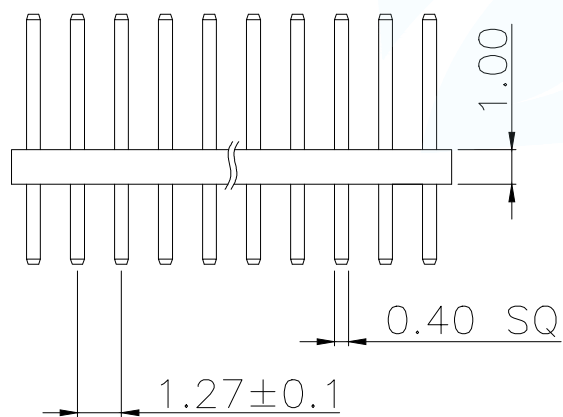

RECOMMEND P.C.B LAYOUT  
 PCB TOLERANCE:±0.05 (TOP VIEW)

PART NUMBER DESCRIPTION:

PH1.27-01-NPZS

(D=单排;S=双排)  
 (Z=直脚;W=弯脚)  
 (PIN数量;01.....50PIN)  
 (排针开关)

MANUFACTURE DWG		东莞市讯普电子科技有限公司 DongGuan XunPu Electronics Co.,Ltd		
UNLESS OTHERWISE SPECIFIED TOLERANCES			TITLE:1.27PH H1.0 2xnPin 180度 W3.4 PC2.3 PA3.9 PB1.0 L7.2 6T	
DECIMALS:	ANGLES:		PAR PH1.27-01-NPZS	
X.±0.30	X°±5'		DWN	
X.X±0.20	X.X°±1'		CHKD	
X.XX±0.10	X.XX°±0.5'	APVD		
CUSTOMER COPY		SCALE N:A	UNIT:MM	
		SIZE:A4	SHEET:1F1	
			REV:A	