

DC-DC Converter DATA Sheet

MYUSP3R303FMP

1. Features

- Ultra small size foot print (8.5mm × 11.0mm), 3A output current, non-isolated POL.
- Wide adjustable output voltage range by connecting external resistance (0.7V to 3.3V).
- Wide operating temperature (-40 °C to +85 °C).
- UVLO function, ON/OFF function, P-GOOD function, Output voltage sense function, Over-current function and, Over-temperature function are built in.



2. Appearance, Dimensions

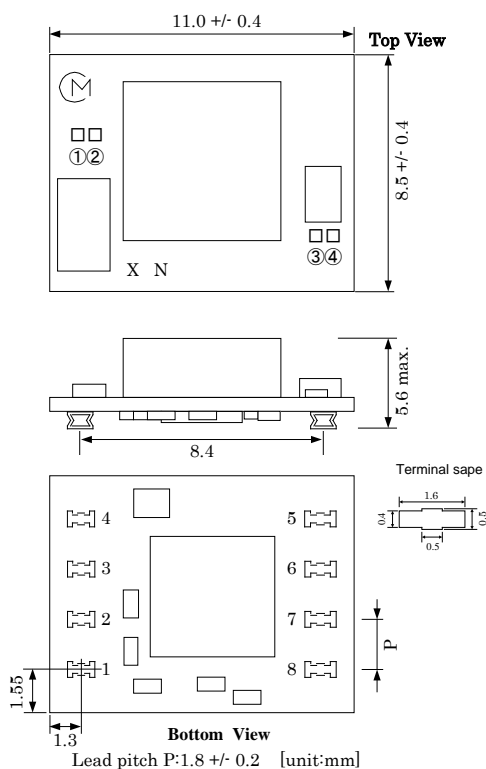

Marking

- | | |
|---------------------------|----------------|
| (1) Pin No.1 Side Marking | (M) |
| (2) Parts Number | XN |
| (3) Manufacturer ID | (M) |
| (4) Lot No. | □□ □□
①② ③④ |

- ① Production Year
 ② Production Month (1,2,3,...9,O,N,D)
 ③④ Production Control Marking

Note:

1. This datasheet is downloaded from the website of Murata Manufacturing co., ltd. Therefore, it's specifications are subject to change or our products in it may be discontinued without advance notice. Please check with our sales representatives or product engineers before ordering.
2. This datasheet has only typical specifications because there is no space for detailed specifications. Therefore, please approve our product specifications or transact the approval sheet for product specifications before ordering.

Pin Number and Function

Pin No.	Symbol	Function
1	TRIM	Output voltage adjustment
2	Vout	Output
3,5	GND	GND
4	+SENSE	Output voltage sense
6	ON/OFF	Remote ON/OFF
7	Vin	Input
8	Pgood	Power good output

3. Block Diagram

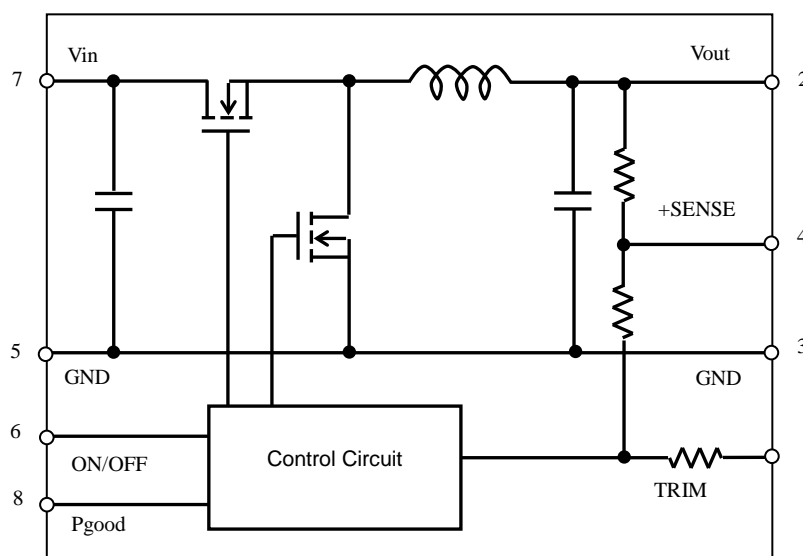

4. Test Circuit

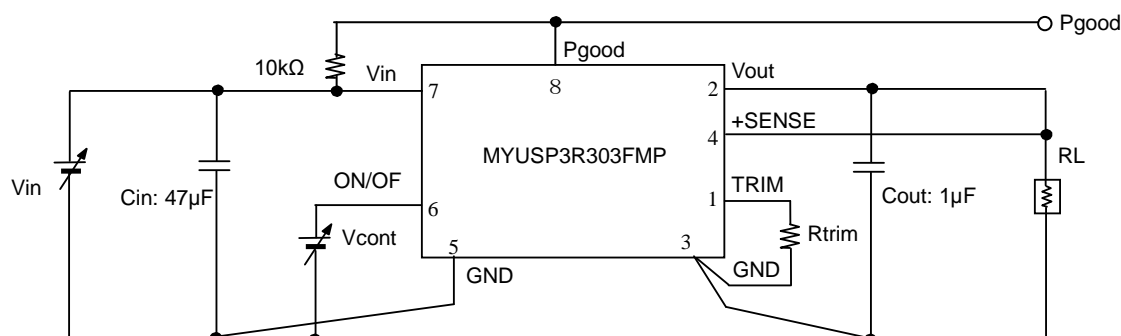

Cin : 47 μ F / 6.3V Ceramic Capacitor
 Cout : 1 μ F / 10V Ceramic Capacitor

Please make sure to place Cin and Cout nearby input and output terminal of DC-DC converter.

Note:

1. This datasheet is downloaded from the website of Murata Manufacturing co., ltd. Therefore, it's specifications are subject to change or our products in it may be discontinued without advance notice. Please check with our sales representatives or product engineers before ordering.
2. This datasheet has only typical specifications because there is no space for detailed specifications. Therefore, please approve our product specifications or transact the approval sheet for product specifications before ordering.

5. Characteristics

5. 1. Electrical Characteristics (Ta=25 °C)

Item	Symbol	Condition	Value			Unit	
			Min.	Typ.	Max.		
Input Voltage Range	Vin		3.0	-	5.5	V	
Output Voltage Adjustable Range	Vout	Vin=3.0V-5.5V Note : VinMin.=Vout+1.2V at Vout≥1.6V	0.7	-	3.3	V	
Output Voltage Tolerance	Vo tol	Over Vin, Temperature range Rset=0.5% tolerance Io=5mA~3A	-3.0	-	+3.0	%Vo	
Output Current	Iout	See the thermal derating curve in section 5.2.	0	-	3	A	
Ripple Voltage	Vrpl	Vin=5V, Vout=1.2V, Iout=3A BW =20MHz,	-	-	80	mV(pp)	
Efficiency	EFF	Vin =5V, Vout=3.3V, Iout=1A	-	94	-	%	
ON/OFF pin High Voltage	VIH		ON	2.0	-	Vin	V
ON/OFF pin Low Voltage	VIL		OFF	0	-	0.8	V
Short Circuit Protection	SCP	When a short circuit state continues, the product becomes the latch up mode and stops.. After correction of the abnormal condition, the DC-DC Converter will restart by re-inputting Vin or toggling On/Off pin.					
Power Good Detection Theshold	Vpg			-10		%Vo	
Soft Start Time	TSS		2	4	8	msec	
Timer Latch Mask Time	Tlatch		0.5	1	2	msec	

*Power Good Detection output is sent when the DC-DC converter begins the output operation (when the output voltage reaches a threshold voltage of Power Good Detection shown in 9.1.3.). PGOOD pin is open drain output.

DC-DC converter is operating : PGOOD-PIN is open.

DC-DC converter is not operating : PGOOD-PIN is pull down to GND internally.

**Caution**

The above electrical characteristics are guaranteed with the condition that the impedance of the input voltage source is sufficiently low as shown in section 4. Connecting an input inductance or using an input power supply with output inductance may cause an unstable operation of this device. Please check the proper operation of this device with the peripheral circuits on your system.

Note:

1. This datasheet is downloaded from the website of Murata Manufacturing co., ltd. Therefore, it's specifications are subject to change or our products in it may be discontinued without advance notice. Please check with our sales representatives or product engineers before ordering.
2. This datasheet has only typical specifications because there is no space for detailed specifications. Therefore, please approve our product specifications or transact the approval sheet for product specifications before ordering.

5. 2. Thermal Derating

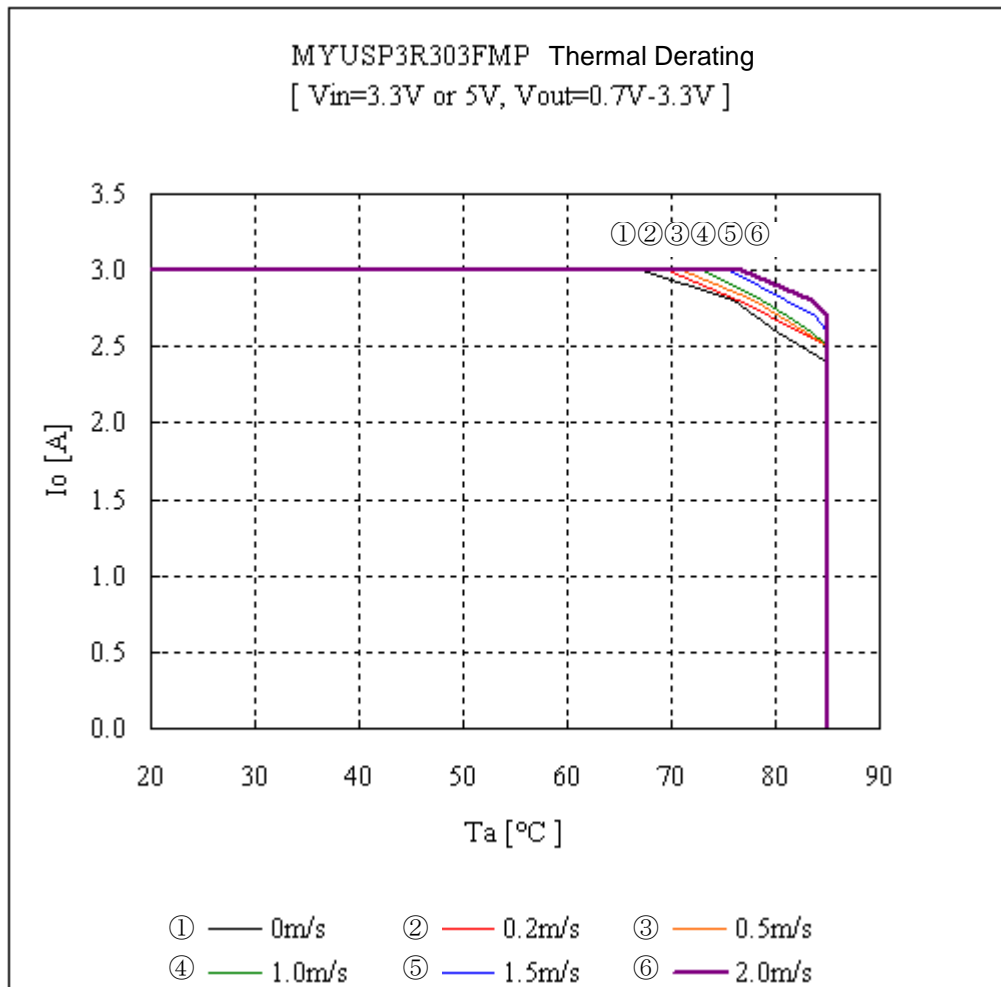

The above derating limits apply to this product soldered directly to 101.6*180mm*1.6mm PCB (double-sided, with 70um copper). Any adjacent parts of high temperature may cause overheating. For reliable operation, please ensure that the IC temperature of this product is maintained below 120°C and the inductor temperature is below 119°C.

Note:

1. This datasheet is downloaded from the website of Murata Manufacturing co., ltd. Therefore, it's specifications are subject to change or our products in it may be discontinued without advance notice. Please check with our sales representatives or product engineers before ordering.
2. This datasheet has only typical specifications because there is no space for detailed specifications. Therefore, please approve our product specifications or transact the approval sheet for product specifications before ordering.

6. Pin Description

6.1. Adjusting the Output Voltage

The output voltage can be adjusted from 0.7V to 3.3V by connecting resistors between TRIM-pin(1Pin) to GND-pin(Pin 3 is recommended for accurate Vout setting).

The following equation gives the required external-resistor values to adjust the output voltage to the required Vout. It is highly recommended that evaluation of the characteristics of this DC-DC converter's operation under your board conditions be thoroughly conducted.

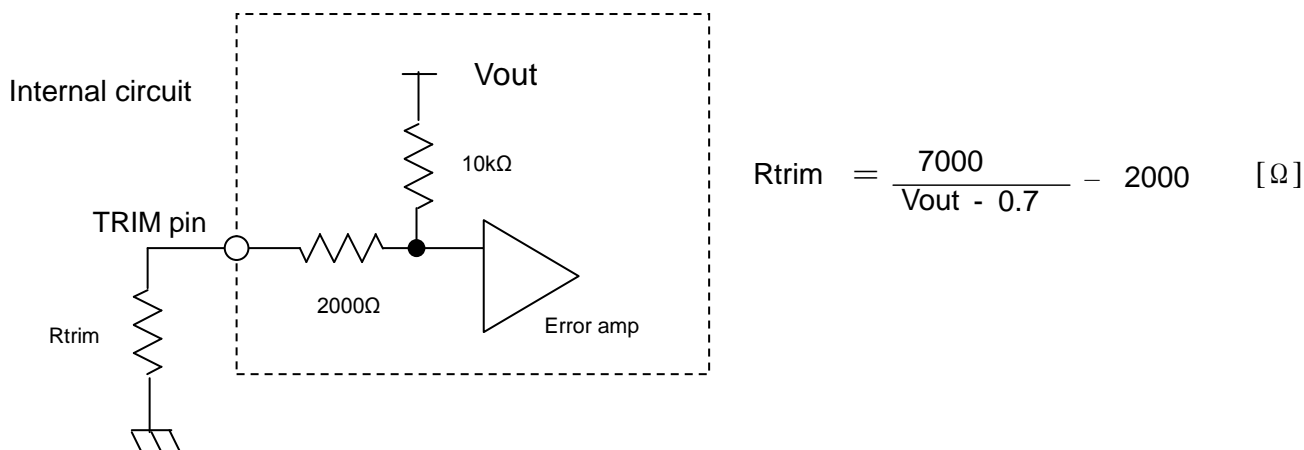

<Rtrim Calculation Example>

Vout(V)	Calculated Rtrim(Ω)	Rtrim Example(Ω)
3.3	692.3	680 + 12
2.5	1888.9	1500 + 390
1.8	4363.6	3900 + 470
1.5	6750	5600 + 1200
1.2	12000	12000
1.0	21333.3	18000 + 3300 + 33
0.8	68000	68000
0.7	∞	Open

6.2. ON/OFF Control

Using the ON/OFF feature, the operation of this product can be disabled without removal of the input voltage. Sequencing of a power supply system and power-saving control can be easily achieved using this function.

When ON/OFF-pin(6pin) is connected to Vin Output Voltage =ON
 When ON/OFF-pin(6pin) is connected to GND Output Voltage =OFF

6.3. Output Voltage Sensing

By connecting SENSE-pin to the load, output voltage drop in wiring shall be compensated. Please do NOT connect SENSE-pin to the output of LC filter that is set to the Vout line. When using this way, this product will not operate properly.

< Caution >

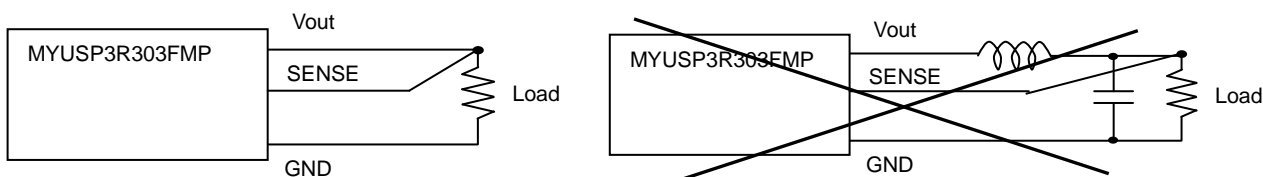

Please connect SENSE-pin to Vout-pin nearby the product, if sense function is not used.

Note:

1. This datasheet is downloaded from the website of Murata Manufacturing co., ltd. Therefore, it's specifications are subject to change or our products in it may be discontinued without advance notice. Please check with our sales representatives or product engineers before ordering.
2. This datasheet has only typical specifications because there is no space for detailed specifications. Therefore, please approve our product specifications or transact the approval sheet for product specifications before ordering.

6.4. Input External capacitor

It is recommended to connect Ceramic capacitor of 47 μ F or more between Vin terminal(7pin) and GND(5pin). But according to Fig6-4, it can smaller capacity value by a combination of input voltage and output voltage. But smaller input capacitor may leads to an unstable operation of this product caused by input voltage fluctuation. When the impedance of input line is enough small, smaller input capacitor can be applied after checking the stable operation on your product.

Please place the input capacitor as close as possible to this product.

Long wiring between the input capacitor and this product may lead to increased radiation noise and unstable operation of this product.

Fig6-4 Input external capacitor by the combination of input voltage and output voltage.
(When Slew Rate of the output current is less than 1A/ μ s.)

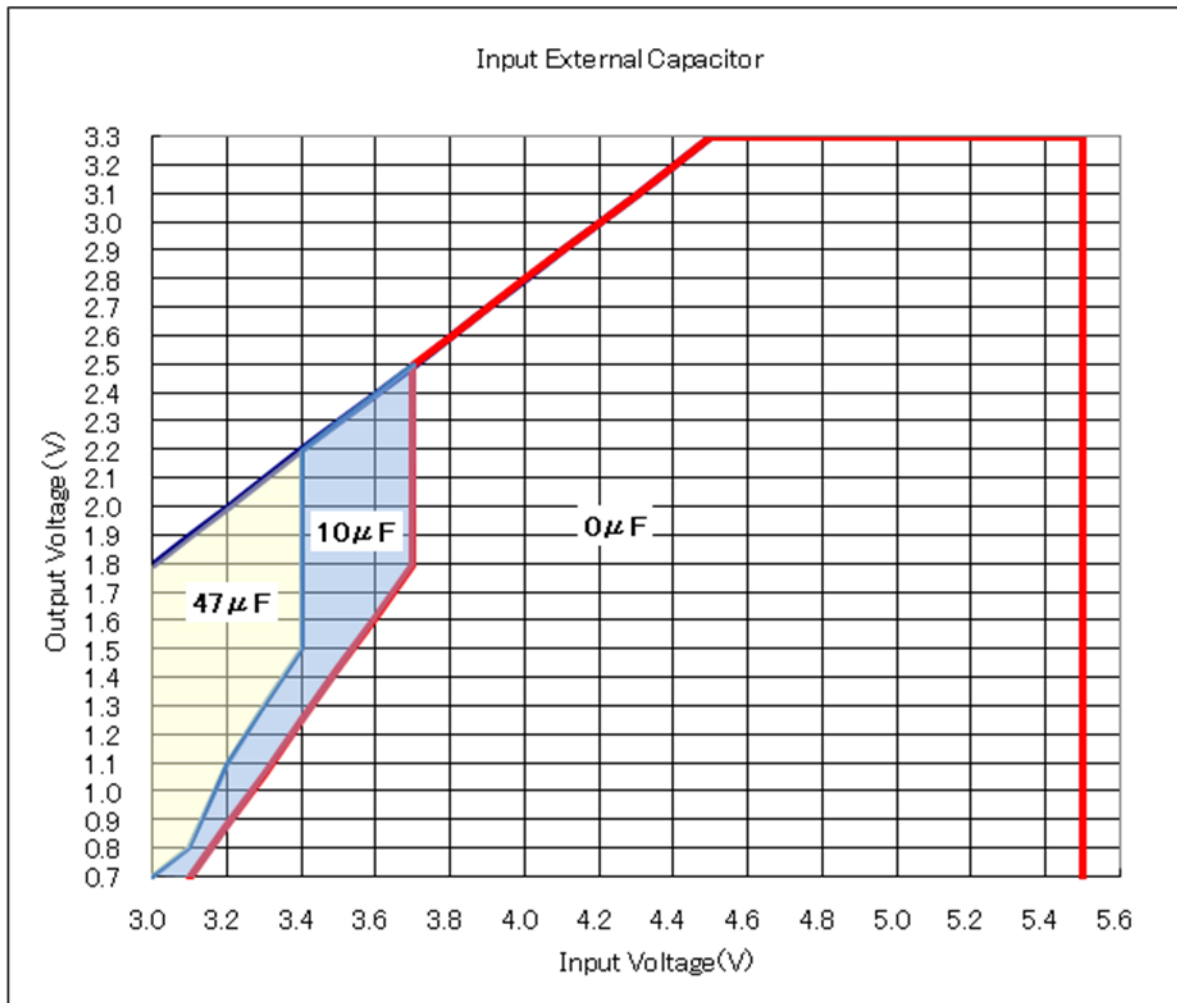

6.5. Output External capacitor

Ceramic capacitors are recommended as output external capacitor. Using ceramic capacitors, small output variation and small ripple voltage are realized.

Output capacitor should be 300 μ F or less. Output capacitor shall be placed near the output terminal.

Note:

1. This datasheet is downloaded from the website of Murata Manufacturing co., Ltd. Therefore, it's specifications are subject to change or our products in it may be discontinued without advance notice. Please check with our sales representatives or product engineers before ordering.
2. This datasheet has only typical specifications because there is no space for detailed specifications. Therefore, please approve our product specifications or transact the approval sheet for product specifications before ordering.

7. Mounting Condition

7.1. PCB Land Pattern Recommendation

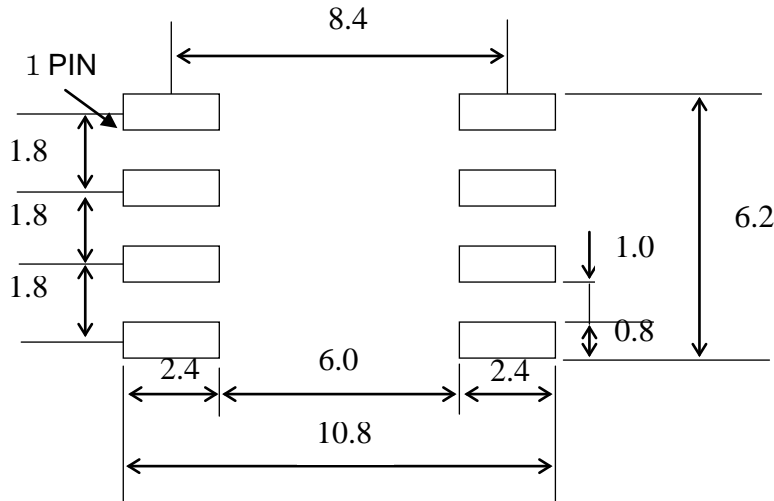

7.2. Recommended Soldering Conditions

Reflow Soldering

This product is RoHS compliant. The following profile is recommended for the reflow of this product using Pb-free solder paste (Sn-Ag-Cu).

Method	: Full convection reflow soldering
Profile details	
Soldering temperature	: 245°C+0/-5°C
Soldering time	: 20 to 60 seconds, over 220°C
Preheating	: 60 to 150 seconds, 150 to 200°C
Programming rate	: 3°C/ sec. Max., 217 to 245°C
Times	: 1 time

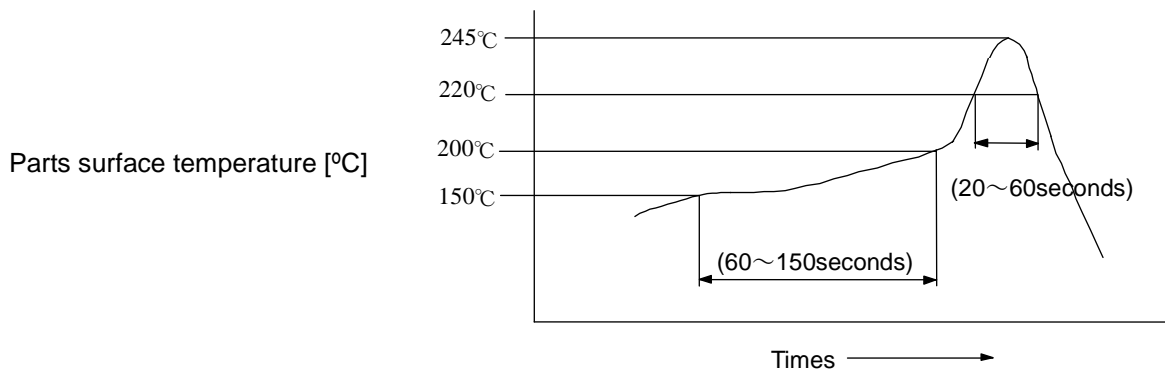

※Do not vibrate for the products on reflow.

Please need to take care temperature control because mounted parts may come off if the product are left under the high temperature.

Do not reflow DC-DC converter as follows, because DC-DC converter may fall down from a substrate during reflowing.

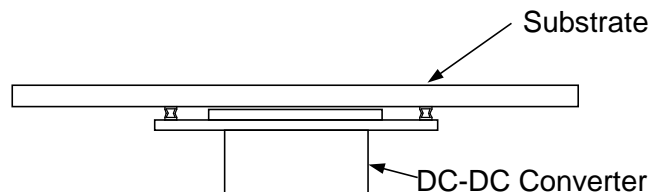

Note:

1. This datasheet is downloaded from the website of Murata Manufacturing co., Ltd. Therefore, it's specifications are subject to change or our products in it may be discontinued without advance notice. Please check with our sales representatives or product engineers before ordering.
2. This datasheet has only typical specifications because there is no space for detailed specifications. Therefore, please approve our product specifications or transact the approval sheet for product specifications before ordering.

8. Packaging Information

8.1. Embossed Tape Dimensions

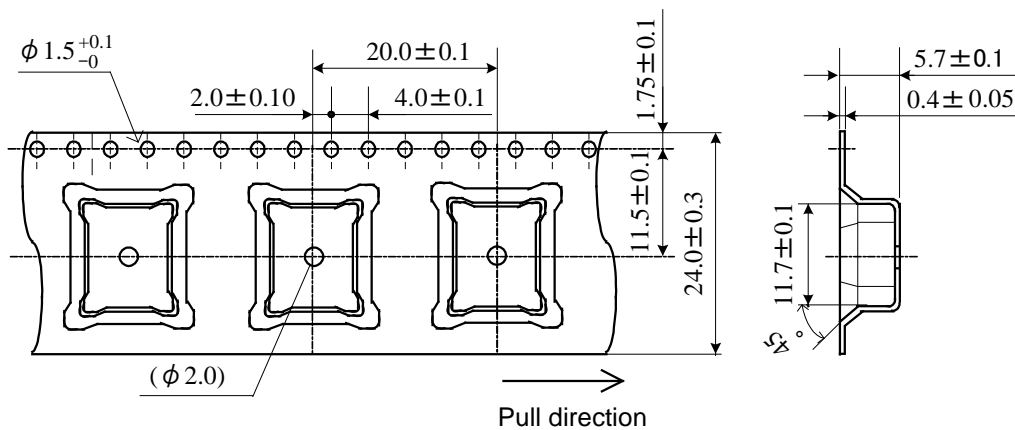

8.2. Reel Dimensions

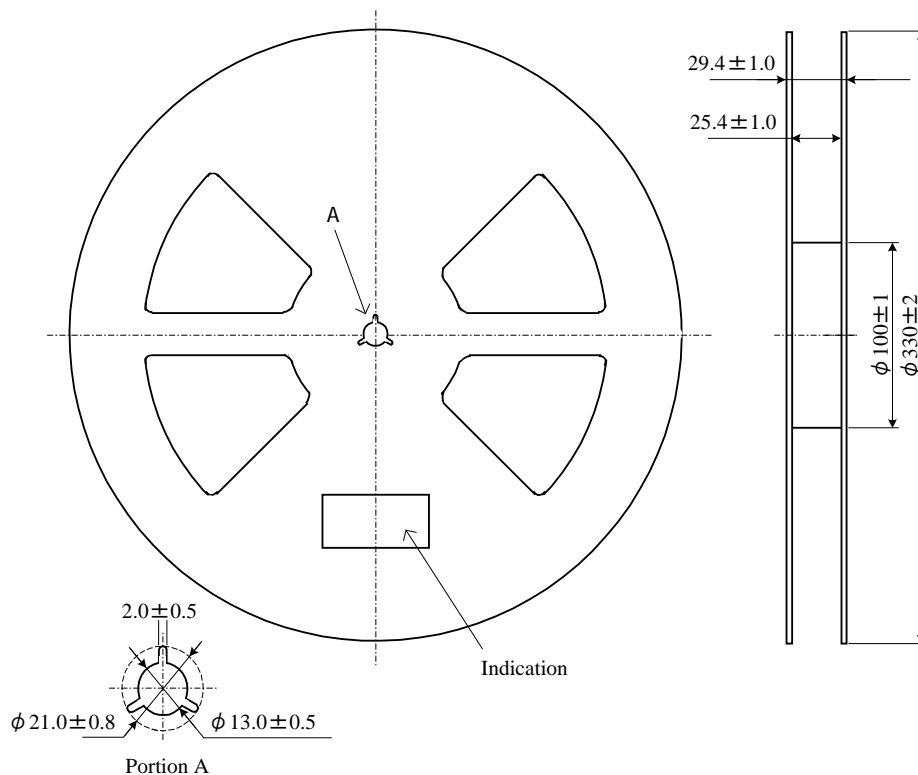

Note We use the reel of the maker of any companies.

Note:

1. This datasheet is downloaded from the website of Murata Manufacturing co., ltd. Therefore, it's specifications are subject to change or our products in it may be discontinued without advance notice. Please check with our sales representatives or product engineers before ordering.
2. This datasheet has only typical specifications because there is no space for detailed specifications. Therefore, please approve our product specifications or transact the approval sheet for product specifications before ordering.

8.3. Taping Specification

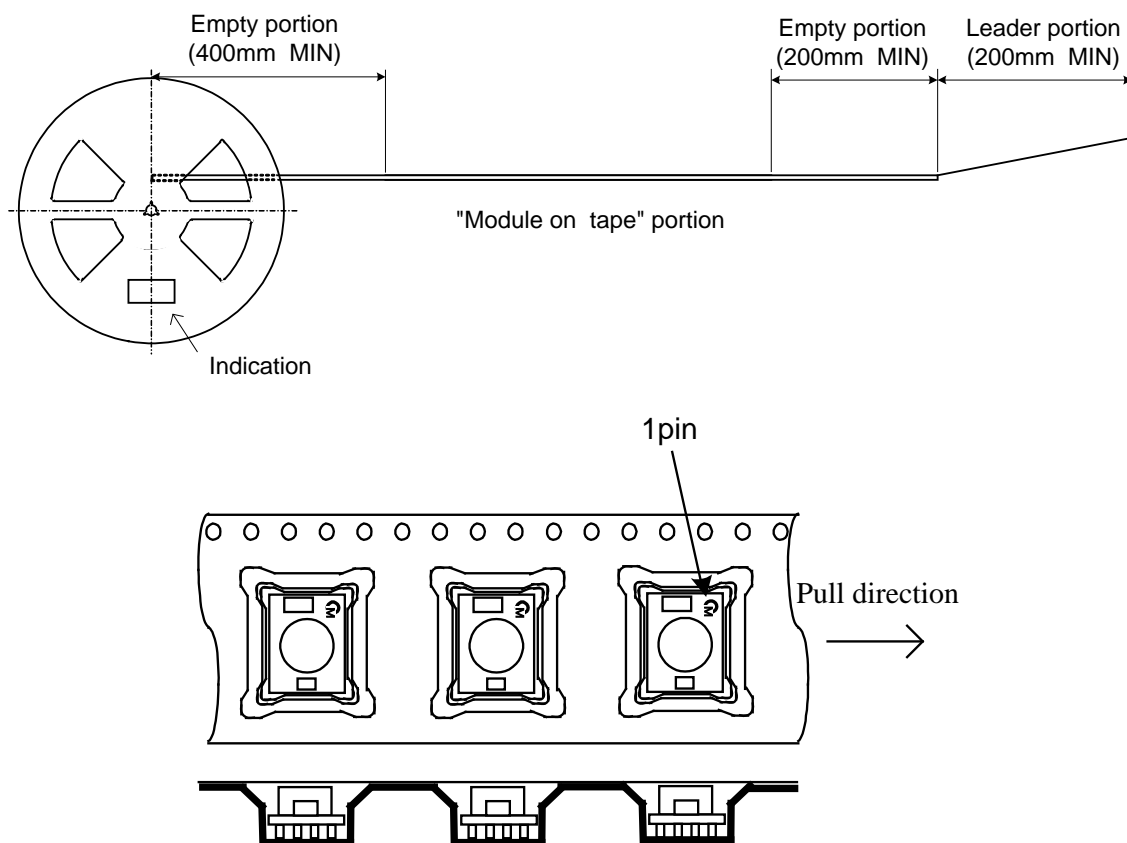

The module is oriented with coil on top and pins on the bottom sides.

8.4. Note

1. The adhesive strength of the protective tape must be within 0.1-1N.
2. Each reel contains 500pcs.
3. No vacant pocket in "Module on tape" section.
4. The reel is labeled with Murata part number and quantity.
5. The color of reel is not specified.

Note:

1. This datasheet is downloaded from the website of Murata Manufacturing co., ltd. Therefore, it's specifications are subject to change or our products in it may be discontinued without advance notice. Please check with our sales representatives or product engineers before ordering.
2. This datasheet has only typical specifications because there is no space for detailed specifications. Therefore, please approve our product specifications or transact the approval sheet for product specifications before ordering.

8.5. Packaging form

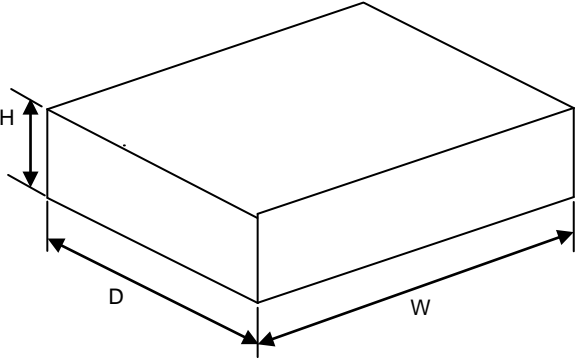
Item	Specification
Packaging form typical classification	Box
Dimensions of packaging form 	$W = 345(\text{ mm })$ $D = 345(\text{ mm })$ $H = 95(\text{ mm })$
The number of products in packaging form	1000 (p c s)
Mass of one product	0.75 typ. (g)
Remark If the products have fraction, may not follow this specification.	

Note:

1. This datasheet is downloaded from the website of Murata Manufacturing co., ltd. Therefore, it's specifications are subject to change or our products in it may be discontinued without advance notice. Please check with our sales representatives or product engineers before ordering.
2. This datasheet has only typical specifications because there is no space for detailed specifications. Therefore, please approve our product specifications or transact the approval sheet for product specifications before ordering.

9. Typical Characteristics Data

9.1. Static Electrical Characteristics

$V_{out}=1.0V$
 $(T_a=25^{\circ}C, C_{in}=GRM32EC80J476K, C_{out}=GRM216B11A105K, R_{trim}=21333\Omega)$

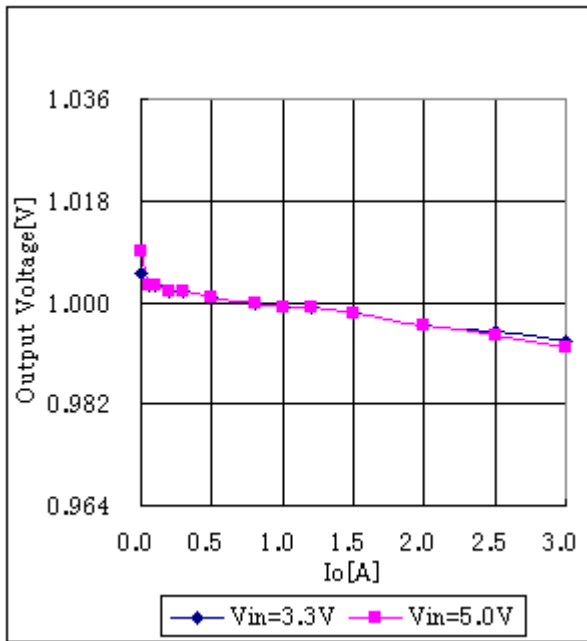

Fig.9-1-1. Output Voltage v.s. Output Current

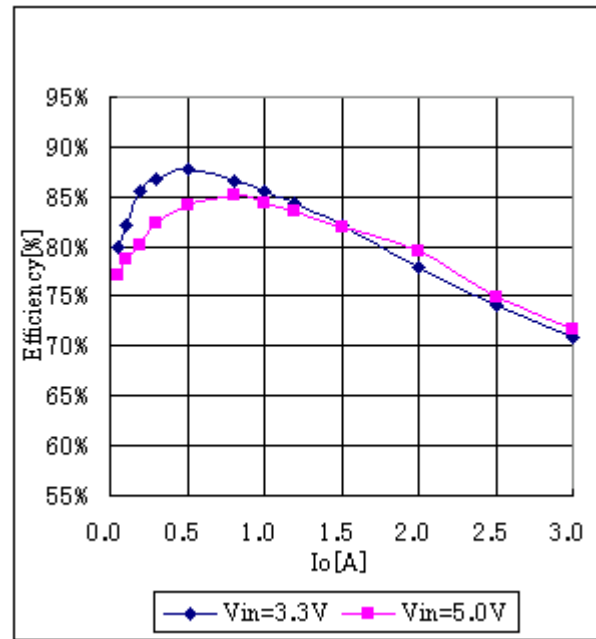

Fig.9-1-2. Efficiency v.s. Output Current

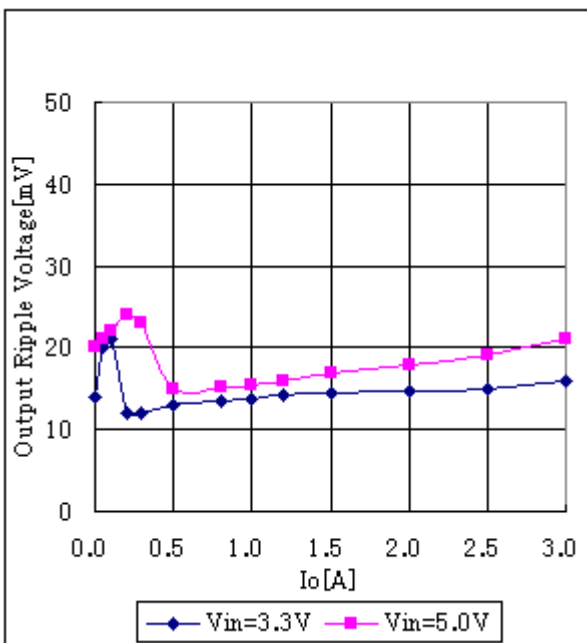

Fig.9-1-3. Ripple Voltage v. s. Output Current

Note:

1. This datasheet is downloaded from the website of Murata Manufacturing co., Ltd. Therefore, it's specifications are subject to change or our products in it may be discontinued without advance notice. Please check with our sales representatives or product engineers before ordering.
2. This datasheet has only typical specifications because there is no space for detailed specifications. Therefore, please approve our product specifications or transact the approval sheet for product specifications before ordering.

$V_{out}=1.2V$
 ($T_a=25^\circ C$, $C_{in}=GRM32EC80J476K$, $C_{out}=GRM216B11A105K$, $R_{trim}=12000\Omega$)

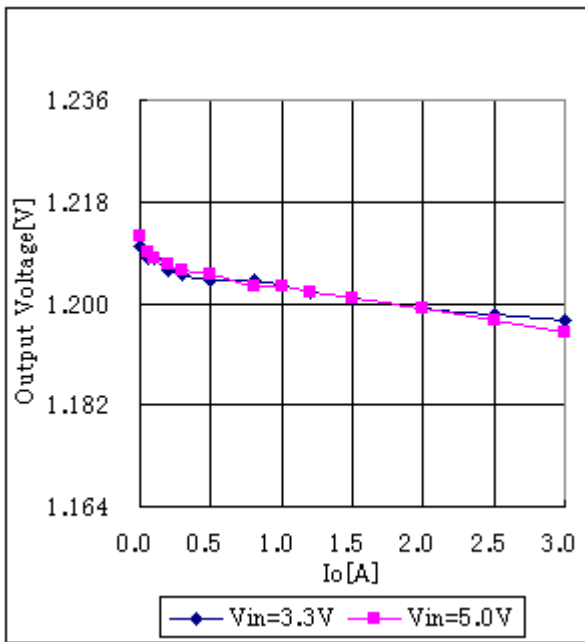

Fig.9-1-4. Output Voltage v.s. Output Current

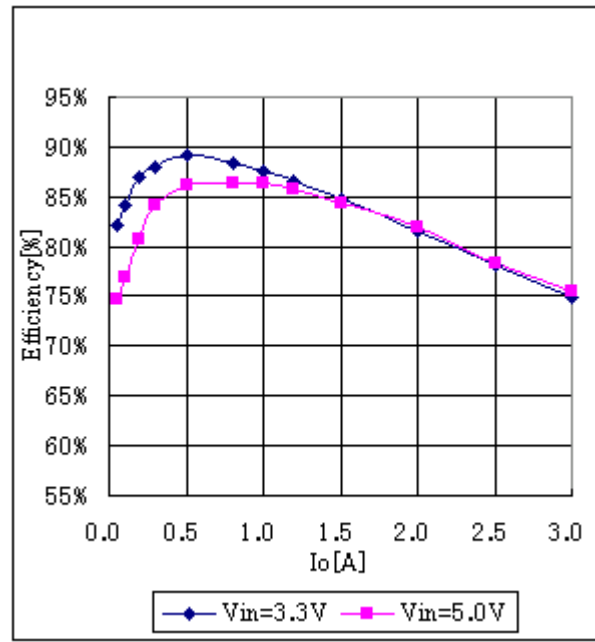

Fig.9-1-5. Efficiency v.s. Output Current

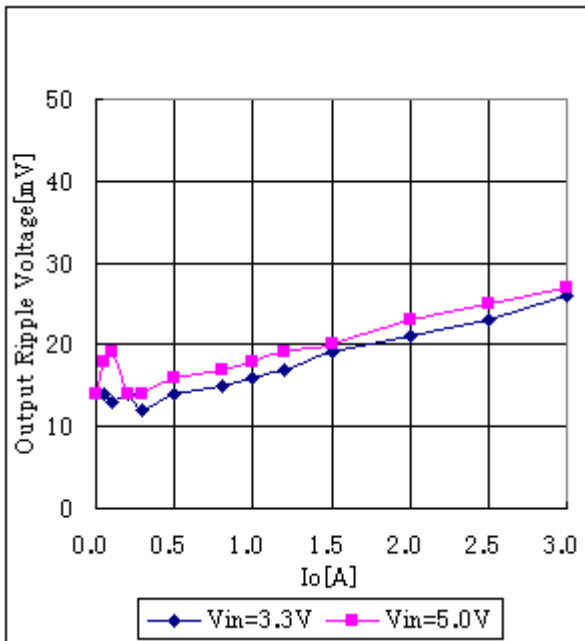

Fig.9-1-6. Ripple Voltage v. s. Output Current

Note:

1. This datasheet is downloaded from the website of Murata Manufacturing co., Ltd. Therefore, it's specifications are subject to change or our products in it may be discontinued without advance notice. Please check with our sales representatives or product engineers before ordering.
2. This datasheet has only typical specifications because there is no space for detailed specifications. Therefore, please approve our product specifications or transact the approval sheet for product specifications before ordering.

$V_{out}=1.8V$
 ($T_a=25^\circ C$, $C_{in}=GRM32EC80J476K$, $C_{out}=GRM216B11A105K$, $R_{trim}=4370\Omega$)

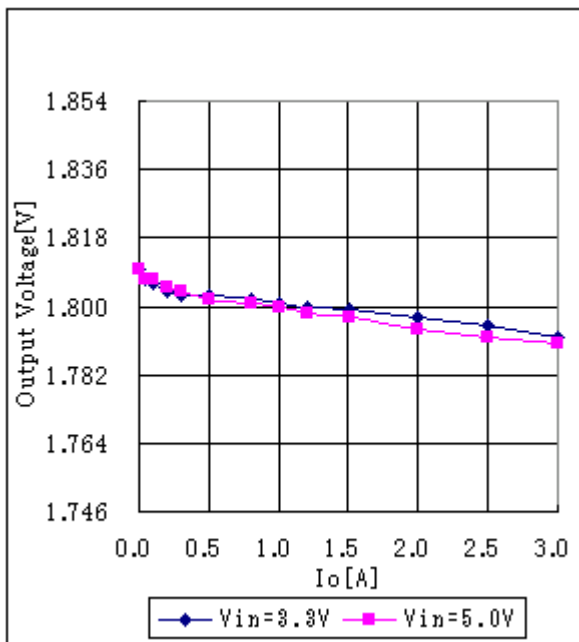

Fig.9-1-7. Output Voltage v.s. Output Current

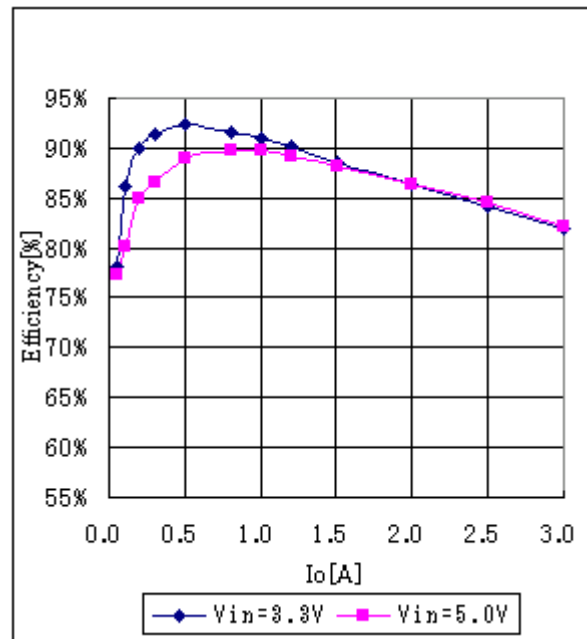

Fig.9-1-8. Efficiency v.s. Output Current

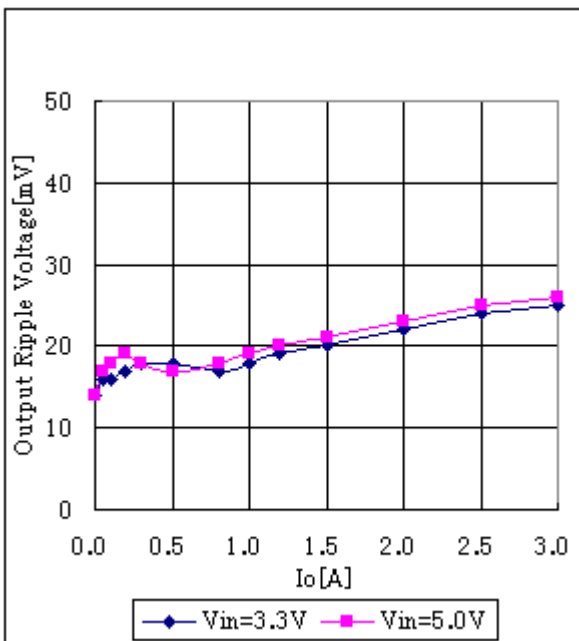

Fig.9-1-9. Ripple Voltage v. s. Output Current

Note:

1. This datasheet is downloaded from the website of Murata Manufacturing co., Ltd. Therefore, it's specifications are subject to change or our products in it may be discontinued without advance notice. Please check with our sales representatives or product engineers before ordering.
2. This datasheet has only typical specifications because there is no space for detailed specifications. Therefore, please approve our product specifications or transact the approval sheet for product specifications before ordering.

$V_{out}=3.3V$
 ($T_a=25^{\circ}C$, $C_{in}=GRM32EC80J476K$, $C_{out}=GRM216B11A105K$, $R_{trim}=692\Omega$)

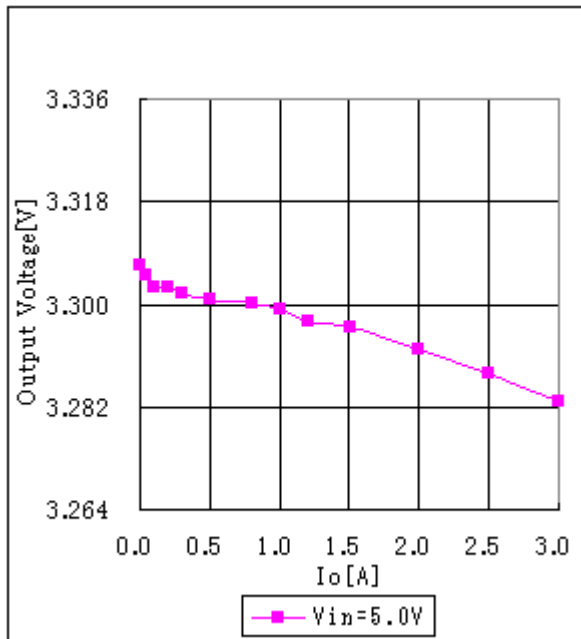

Fig.9-1-10. Output Voltage v.s. Output Current

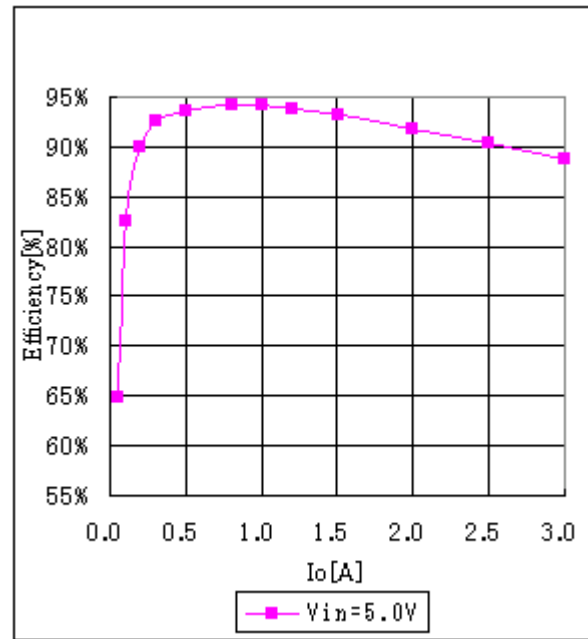

Fig.9-1-11. Efficiency v.s. Output Current

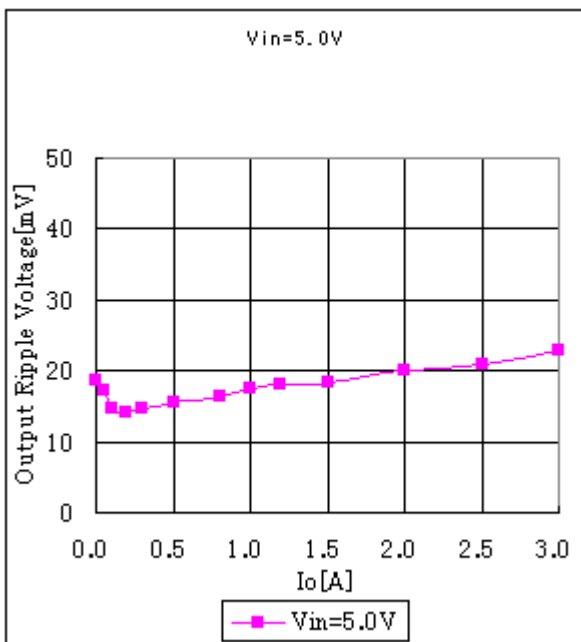

Fig.9-1-12. Ripple Voltage v. s. Output Current

Note:

1. This datasheet is downloaded from the website of Murata Manufacturing co., ltd. Therefore, it's specifications are subject to change or our products in it may be discontinued without advance notice. Please check with our sales representatives or product engineers before ordering.
2. This datasheet has only typical specifications because there is no space for detailed specifications. Therefore, please approve our product specifications or transact the approval sheet for product specifications before ordering.

9.2. Dynamic Electrical Characteristics

$V_{in}=3.3V$, $V_{out}=1.2V$

($T_a=25^{\circ}C$, $C_{in}=GRM32EC80J476K$, $C_{out}=GRM216B11A105K$, $R_{trim}=12000\Omega$)

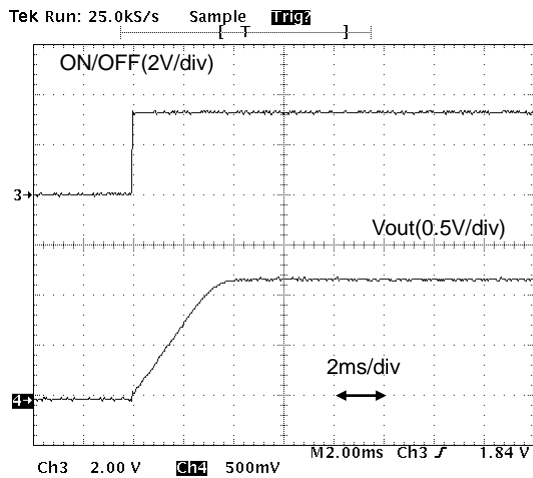
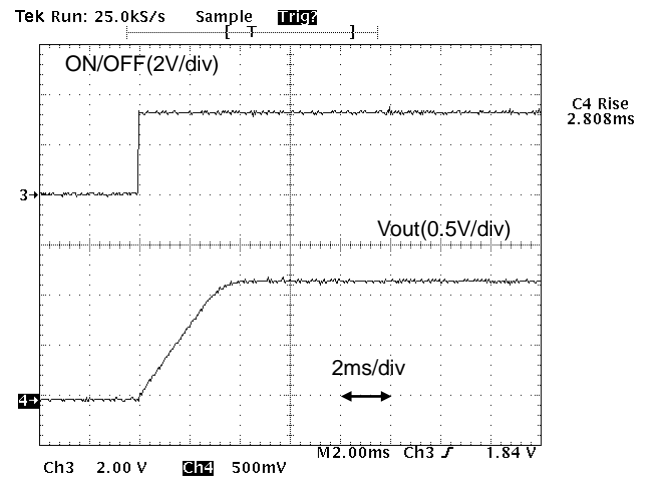
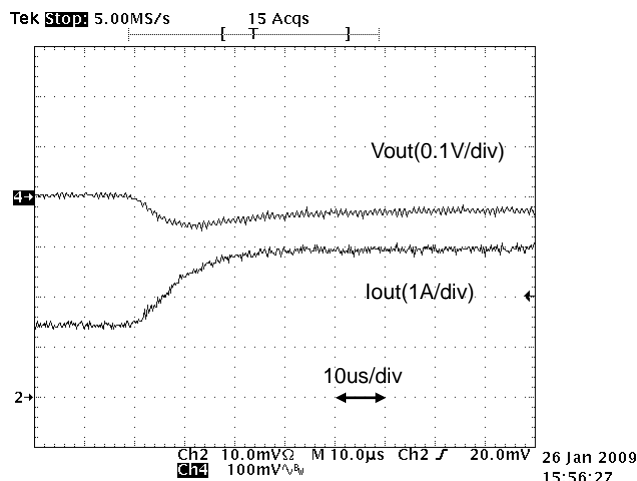
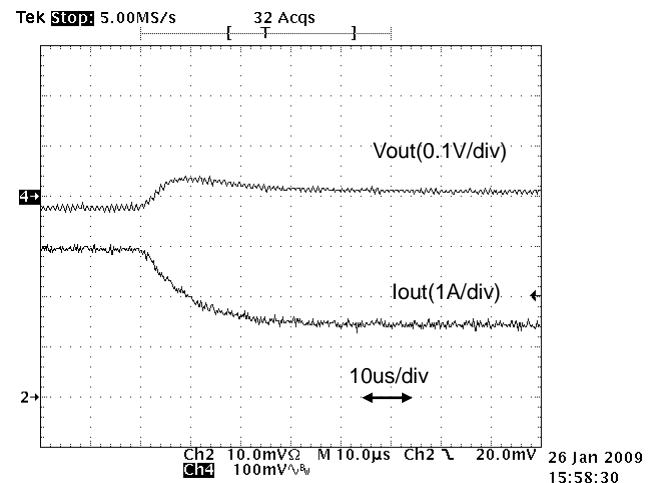
Fig.9-2-1. Start-up Waveform ($I_o=0A$)Fig.9-2-2. Start-up Waveform ($I_o=3A$)Fig.9-2-3. Load Transient Response ($I_o=1.5\rightarrow 3A$)Fig.9-2-4. Load Transient Response ($I_o=3\rightarrow 1.5A$)**Note:**

1. This datasheet is downloaded from the website of Murata Manufacturing co., ltd. Therefore, it's specifications are subject to change or our products in it may be discontinued without advance notice. Please check with our sales representatives or product engineers before ordering.
2. This datasheet has only typical specifications because there is no space for detailed specifications. Therefore, please approve our product specifications or transact the approval sheet for product specifications before ordering.

Vin=5.0V, Vout=1.2V
 (Ta=25 °C, Cin= GRM32EC80J476K, Cout= GRM216B11A105K, Rtrim=12000Ω)

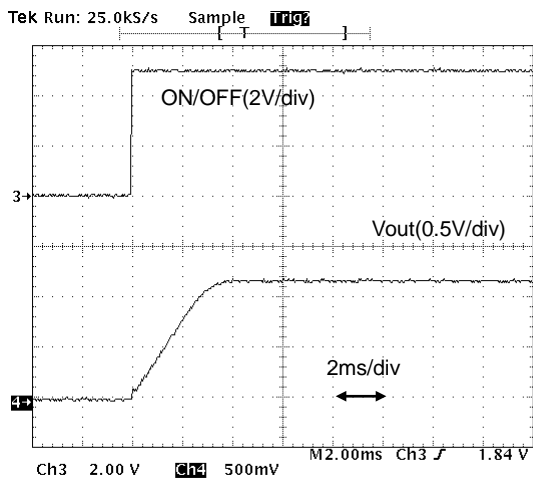

Fig.9-2-5. Start-up Waveform (Io=0A)

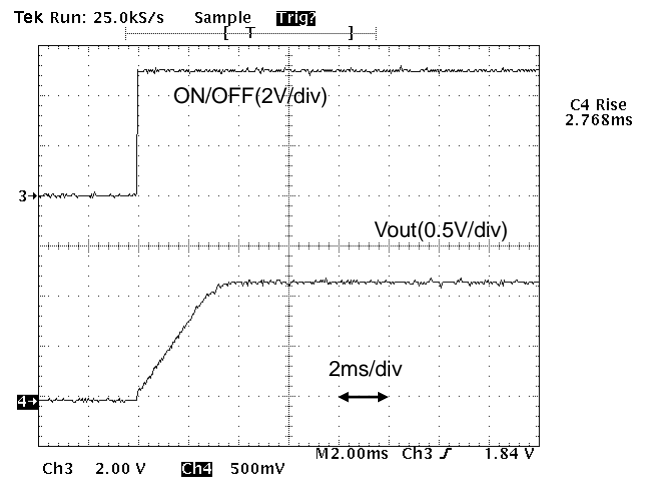

Fig.9-2-6. Start-up Waveform (Io=3A)

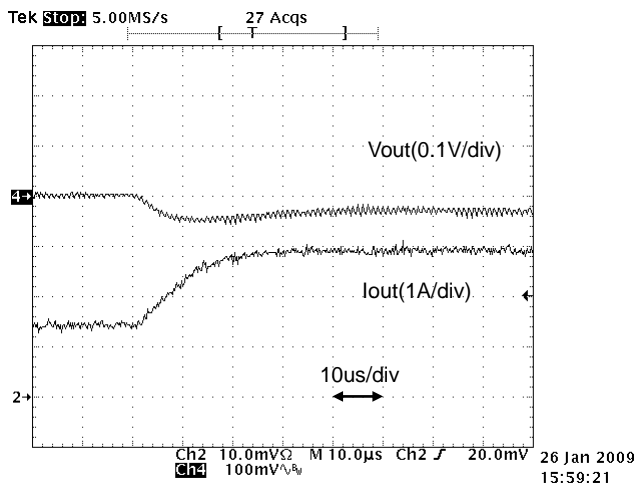

Fig.9-2-7. Load Transient Response (Io=1.5->3A)

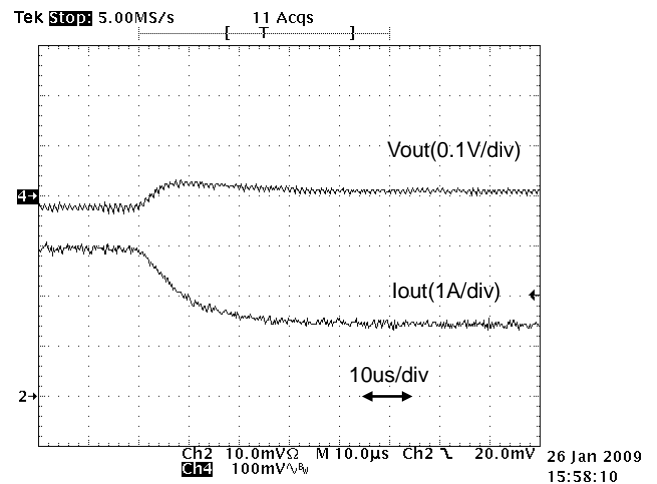

Fig.9-2-8. Load Transient Response (Io=3->1.5A)

Note:

1. This datasheet is downloaded from the website of Murata Manufacturing co., ltd. Therefore, it's specifications are subject to change or our products in it may be discontinued without advance notice. Please check with our sales representatives or product engineers before ordering.
2. This datasheet has only typical specifications because there is no space for detailed specifications. Therefore, please approve our product specifications or transact the approval sheet for product specifications before ordering.

10. Notice

- 10.1. Please do not use a connector or a socket for connection with your board of this product. Electrical performance may be deteriorated the influence of contact resistance. Please be sure to mount this product with solder.
- 10.2. Be sure to provide an appropriate fail-safe function on your product to prevent a second damage that may be caused by the abnormal function or the failure of our product.

10.3. Input / Output capacitor

When a inductance or a switch devise are connected to the input line, or when you use a power supply with output inductance as the input voltage source, the input voltage of the DC-DC converter will be fluctuated. By this input voltage fluctuation, the transient load response of the DC-DC converter may be deteriorated or abnormal oscillation may occur. So please confirm normal operation on each application. Please use external input capacitor in order to decrease inductance of input line.

10.4. Wiring of input / output capacitor

In the case of input / output capacitor connection, in order to reduce electrical noise, please design PCBs with consideration of the following item.

- ①. Please be sure to check normal operation on your system.
- ②. Please use low impedance capacitors with good high frequency characteristic.
- ③. Please shorten those leads of each capacitor as much as possible, and make sure the lead Inductance low.
- ④. Both input-side and output side, please make the wiring loop between plus and minus as small as possible. The influence of leakage inductance can be reduced.
- ⑤. Please design the print pattern of the main circuit as wide and short as possible.

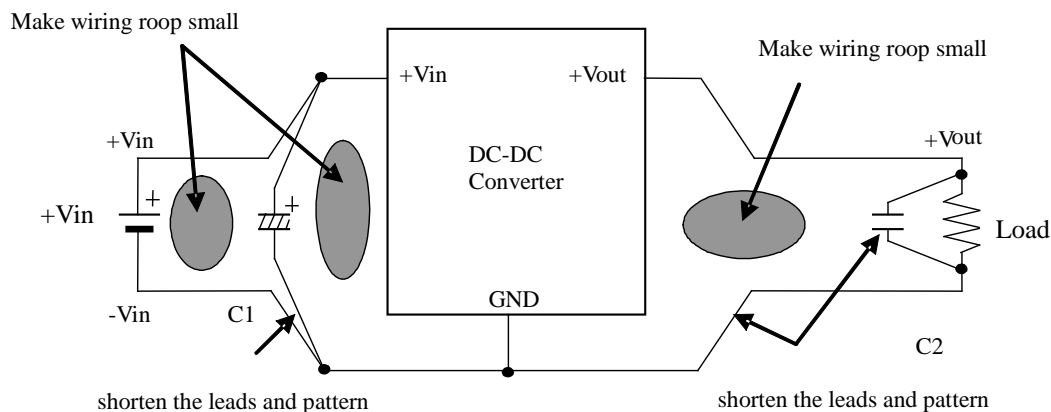

10.5. This product should not be operated in parallel or in series.

10.6. Inrush current protection is not a feature of this product.

Please be careful that surge voltage caused by wiring inductance etc. may make the product damage when input voltage is applied suddenly to the product.

10.7. Please connect the input terminal with proper polarity. If you connect wrong polarity, the DC-DC Converter may be broken. In the case of the DC-DC Converter is damaged, abnormal input current may flow in, and abnormal overheat of the DC-DC Converter, or some damage of your products may occur. Please use a diode and a fuse to as following figure.

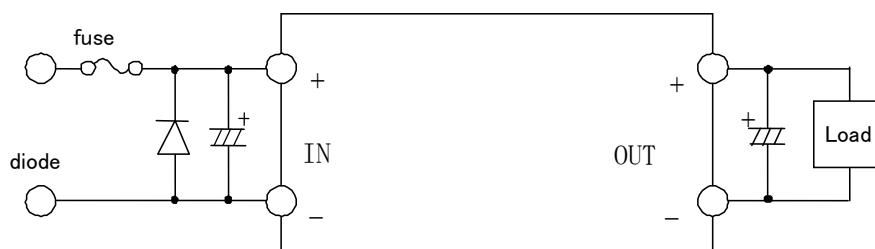

※Please select diode and fuse after confirming the operation.

⚠ Note:

1. This datasheet is downloaded from the website of Murata Manufacturing co., Ltd. Therefore, it's specifications are subject to change or our products in it may be discontinued without advance notice. Please check with our sales representatives or product engineers before ordering.
2. This datasheet has only typical specifications because there is no space for detailed specifications. Therefore, please approve our product specifications or transact the approval sheet for product specifications before ordering.

10.8. Cleaning

Please use no-cleaning type flux and do not wash this product.

10.9. Storage

10.9.1. Please store the products in room where the temperature/humidity is stable and direct sunlight cannot come in, and use the products within 6 months after delivery.

Please avoid damp and heat or such places where the temperature greatly changes, as water may condense on this product, and the quality of characteristics may be reduced, and/or the solderability may be degraded.

If this product needs to be stored for a long time (more than 1 year), this product may be degraded in solderability and/or corroded. Please test the solderability of this product regularly.

Baking before reflow process is unnecessary to store the products under 30°C,60%RH or less up to 6 months.

In case the storage condition is over above mentioned, if these are unpacked condition, please bake them at 125°C±5°C/24hour. If these are packed in a tape, please bake them before soldering at 60°C±5°C/168hour.

10.9.2. Please do not store this product in places such as :

A dusty place, a place exposed directly to sea breeze, or in an atmosphere containing corrosive gas (Cl₂,NH₃,SO₂,NOX and so on).

10.10. Operational Environment and Operational Conditions

10.10.1. Operational Environment

The products are not waterproof, chemical-proof or rust-proof.

In order to prevent leakage of electricity and abnormal temperature increase of the products, do not use the products under the following circumstances:

- (1) in an atmosphere containing corrosive gas (Cl₂, NH₃, SO₂, NOX and so on).
- (2) in a dusty place.
- (3) in a place exposed to direct sunlight.
- (4) in such a place where water splashes or in such a humid place where water condenses.
- (5) in a place exposed to sea breeze.
- (6) in any other places similar to the above (1)through (5).

10.10.2. Operational Conditions

Please use the products within specified values (power supply, temperature, input, output and load condition, and so on). Input voltage drop for line impedance, so please make sure that input voltage is included in specified values.

If you use the products over the specified values, it may break the products, reduce the quality, and even if the products can endure the condition for short time, it may cause degradation of the reliability.

Also please take care that the external voltage over output voltage of DC-DC Converter does not applies to output of this DC-DC Converter.

10.10.3. Note prior to use

If you apply high static electricity, over rated voltage or reverse voltage to the products, it may cause defects in the products or degrade the reliability.

Please avoid the following items:

- (1) over rating power supply, reverse power supply or not-enough connection of 0 V(DC) line.
- (2) electrostatic discharge by production line and/or operator.
- (3) electrified product by electrostatic induction.

Do not give an excessive mechanical shock.

If you drop the products on the floor, etc., it may occur a crack to the core of inductors and monolithic ceramic capacitors.

Do not give a strong shock such as a drop in handling.

10.11. Transportation

If you transport the products, please pack them so that the package will not be damaged by mechanical vibration or mechanical shock, and please educate and guide a carrier to prevent rough handling.

If you transport the products to overseas (in particular, by sea), it is expected that the transportation environment will be the worst, so please pack the products, in the package designed on the consideration of mechanical strength, vibration-resistant and humidity-resistant. The package of the products which Murata sells in Japan, may not resist over seas transport.

Please consult us if you are to use the Murata package of the products sold in Japan for transport to overseas.

Note:

1. This datasheet is downloaded from the website of Murata Manufacturing co., Ltd. Therefore, it's specifications are subject to change or our products in it may be discontinued without advance notice. Please check with our sales representatives or product engineers before ordering.
2. This datasheet has only typical specifications because there is no space for detailed specifications. Therefore, please approve our product specifications or transact the approval sheet for product specifications before ordering.

**Note**

1. Murata recommends that customers ensure that the evaluation and testing of these devices are completed with this product actually assembled on their product.
2. Please contact our main sales office or nearby sales office before using our products for the applications listed below which require especially high reliability for the prevention of defects which might directly cause damage to the third party's life, body or property or this products for any other applications that described in the above.
 - ① Aircraft equipment
 - ② Aerospace equipment
 - ③ Undersea equipment
 - ④ Power plant control equipment
 - ⑤ Medical equipment
 - ⑥ Transportation equipment (vehicles, trains, ships, etc.)
 - ⑦ Traffic signal equipment
 - ⑧ Disaster prevention /crime prevention equipment
 - ⑨ Data-processing equipment
 - ⑩ Application of similar complexity and/or reliability requirements to the applications listed in the above.
3. If you have any concerned materials other than RoHS directive, please contact us.
4. About the written contents, since changing without a preliminary announcement for improvement and supply are sometimes stopped, please confirm in case of ordering.

Note:

1. This datasheet is downloaded from the website of Murata Manufacturing co., ltd. Therefore, it's specifications are subject to change or our products in it may be discontinued without advance notice. Please check with our sales representatives or product engineers before ordering.
2. This datasheet has only typical specifications because there is no space for detailed specifications. Therefore, please approve our product specifications or transact the approval sheet for product specifications before ordering.

Mouser Electronics

Authorized Distributor

Click to View Pricing, Inventory, Delivery & Lifecycle Information:

[Murata:](#)

[MYUSP3R303FMP](#)