

**SPTECH Silicon NPN Power Transistor**

**MJE13009**

**DESCRIPTION**

- Collector–Emitter Sustaining Voltage  
:  $V_{CEO(SUS)} = 400V(\text{Min.})$
- Collector Saturation Voltage  
:  $V_{CE(sat)} = 1.5 (\text{Max}) @ I_C = 8.0A$
- Switching Time  
:  $t_f = 0.7 \mu s(\text{Max.}) @ I_C = 8.0A$

**APPLICATIONS**

- Designed for use in high-voltage, high-speed, power switching in inductive circuit, they are particularly suited for 115 and 220V switchmode applications such as switching regulators, inverters, Motor controls, Solenoid/Relay drivers and deflection circuits.

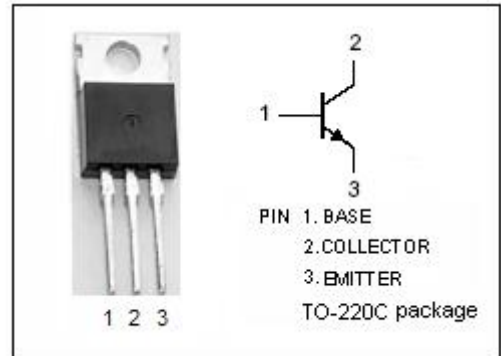

**ABSOLUTE MAXIMUM RATINGS( $T_a=25^\circ C$ )**

SYMBOL	PARAMETER	VALUE	UNIT
$V_{CEV}$	Collector-Emitter Voltage	700	V
$V_{CEO}$	Collector-Emitter Voltage	400	V
$V_{EBO}$	Emitter-Base Voltage	9	V
$I_C$	Collector Current-Continuous	12	A
$I_{CM}$	Collector Current-peak	24	A
$I_B$	Base Current	6	A
$I_{BM}$	Base Current-Peak	12	A
$I_E$	Emitter Current	18	A
$I_{EM}$	Emitter Current-Peak	36	A
$P_C$	Collector Power Dissipation $T_C=25^\circ C$	100	W
$T_j$	Junction Temperature	150	$^\circ C$
$T_{stg}$	Storage Temperature Range	-65~150	$^\circ C$

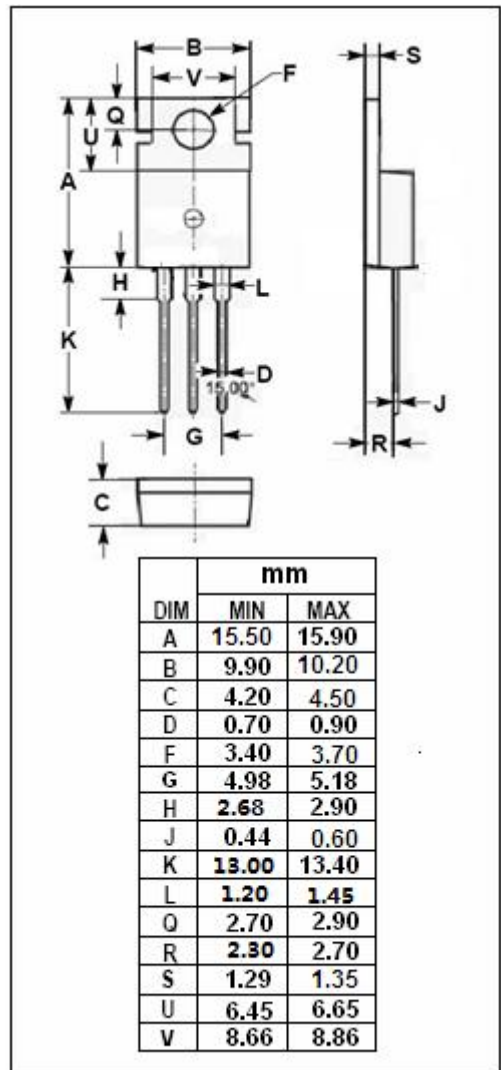

**THERMAL CHARACTERISTICS**

SYMBOL	PARAMETER	MAX	UNIT
$R_{th\ j-c}$	Thermal Resistance, Junction to Case	1.25	$^\circ C/W$
$R_{th\ j-a}$	Thermal Resistance, Junction to Ambient	62.5	$^\circ C/W$

**ELECTRICAL CHARACTERISTICS**

$T_C = 25^\circ\text{C}$  unless otherwise specified

SYMBOL	PARAMETER	CONDITIONS	MIN	TYP.	MAX	UNIT
$V_{CEO(SUS)}$	Collector-Emitter Sustaining Voltage	$I_C = 10\text{mA}; I_B = 0$	400			V
$V_{CE(sat)-1}$	Collector-Emitter Saturation Voltage	$I_C = 5\text{A}; I_B = 1\text{A}$			1.0	V
$V_{CE(sat)-2}$	Collector-Emitter Saturation Voltage	$I_C = 8\text{A}; I_B = 1.6\text{A}$ $T_C = 100^\circ\text{C}$			1.5 2.0	V
$V_{CE(sat)-3}$	Collector-Emitter Saturation Voltage	$I_C = 12\text{A}; I_B = 3\text{A}$			3.0	V
$V_{BE(sat)-1}$	Base-Emitter Saturation Voltage	$I_C = 5\text{A}; I_B = 1\text{A}$			1.2	V
$V_{BE(sat)-2}$	Base-Emitter Saturation Voltage	$I_C = 8\text{A}; I_B = 1.6\text{A}$ $T_C = 100^\circ\text{C}$			1.6 1.5	V
$I_{CBO}$	Collector Cutoff Current	$V_{CB} = 700\text{V}; I_E = 0$ $T_C = 100^\circ\text{C}$			1 5	mA
$I_{EBO}$	Emitter Cutoff Current	$V_{EB} = 9\text{V}; I_C = 0$			1	mA
$h_{FE-1}$	DC Current Gain	$I_C = 5\text{A}; V_{CE} = 5\text{V}$	8		40	
$h_{FE-2}$	DC Current Gain	$I_C = 8\text{A}; V_{CE} = 5\text{V}$	6		30	
$f_T$	Current-Gain—Bandwidth Product	$I_C = 0.5\text{A}; V_{CE} = 10\text{V};$	4			MHz
$C_{OB}$	Output Capacitance	$I_E = 0; V_{CB} = 10\text{V}; f_{test} = 0.1\text{MHz}$		180		pF

Switching Times; Resistive Load

$t_d$	Storage Time	$I_C = 8\text{A}; V_{CC} = 125\text{V};$ $I_{B1} = I_{B2} = 1.6\text{A}; t_p = 25\ \mu\text{s};$ Duty Cycle $\leq 1\%$			0.1	$\mu\text{s}$
$t_r$	Fall Time				1.0	$\mu\text{s}$
$t_s$	Storage Time				3.0	$\mu\text{s}$
$t_f$	Fall Time				0.7	$\mu\text{s}$