

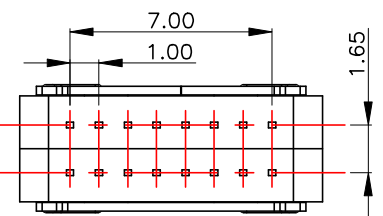

REV.	ECN NO OR DESCRIPTION	REVISED	DATE

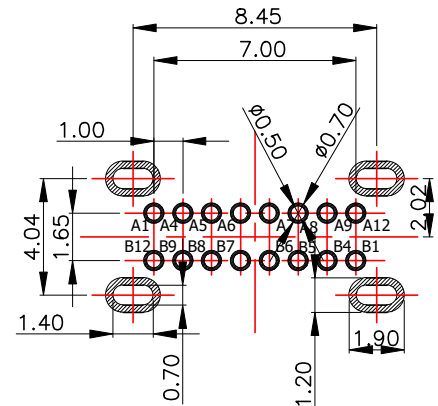
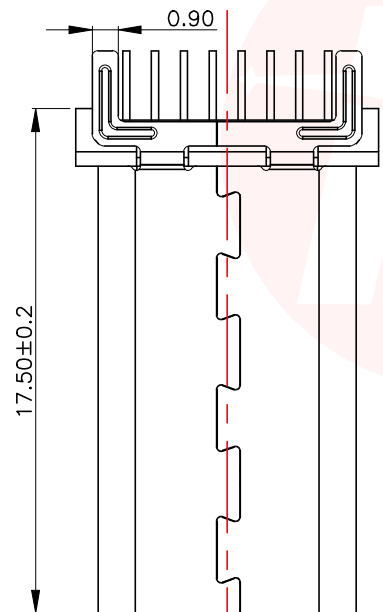
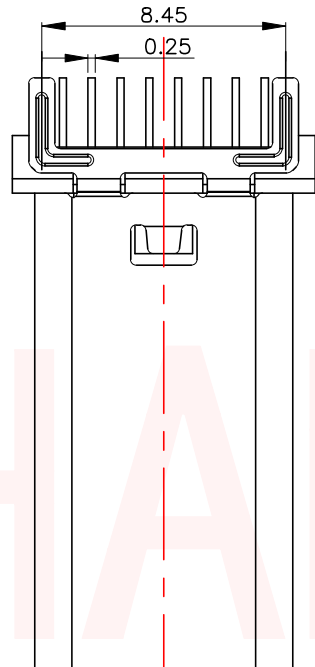
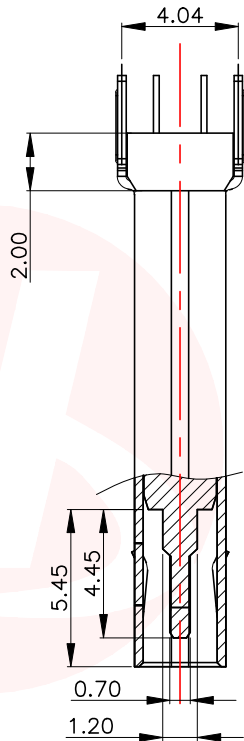
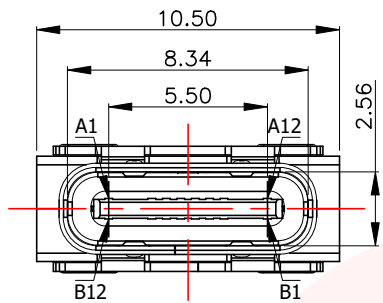

特性:

- 一、电气性能: ELECTRICAL
 - 1. 额定电流: 5.0A
 - 2. 接触阻抗: 40 MILLIOHMS MAX
 - 3. 耐电压: 100V AC / 1 mA MAX
 - 4. 绝缘阻抗: 150V DC/100 MEGA OHMS MIN
- 二、机械性能:
 - 1. 插入力: 5~20N 2. 拨出力: 8~20N
 - 3. 使用寿命: 10000次、拨出力 5N MIN
- 三、材料: MATERIAL
- 四、电镀: FINISH
 - 1. 端子: 接触点镀金1U"MIN
PIN脚焊接区域镀锡80U"MIN
 - 2. 外壳: 镀镍80U"MIN (盐雾48H)
- 五、电镀品需做粘锡测试: 粘锡面积达到95%以上。
- 六、SMT回流焊 (峰值260° C±5° C) 不能起泡、熔胶、变色不良 (变形在公差范围以内)
- 七、工作温度: -55° C~+85° C
- 八、盐雾测试: 通过24H在浓度为5±1%盐水的盐雾测试无生锈现象

A1	A2	A3	A4	A5	A6	A7	A8	A9	A10	A11	A12
GND			VBUS	CC1	D+	D-	SBU1	VBUS			GND
GND			VBUS	SBU2	D-	D+	CC2	VBUS			GND
B12	B11	B10	B9	B8	B7	B6	B5	B4	B3	B2	B1

UNLESS OTHERWISE SPECIFIED TOLERANCES

DECIMALS: X :±0.10 X.X :±0.05 X.XX :±0.02

ANGLES: X :±2° X.X :±1°

东莞市汉博电子科技有限公司
DONGGUAN HANBO TECHNOLOGY CO., LTD

TITLE: TYPE C 16PIN 立插 DIP H=17.5

DWN: xiong PART NO. MC-118LD-H175

CHKD: lee SCALE:1:1 UNIT: mm

APVD: wang SIZE: A4 SHEET:10F 1 REV: A4

CUSTOMER COPY