

# MCSXTE2BK142 Hardware User Guide



# Contents

**Chapter 1 Features..... 3**

**Chapter 2 Hardware system block diagram..... 5**

**Chapter 3 The Board Sub-module Function Circuit Design Details..... 7**

- 3.1 Power supply circuit..... 7
- 3.2 MCU circuit..... 8
- 3.3 Gate driver circuit..... 9
- 3.4 Power stage and signal condition circuit..... 10
- 3.5 CAN/LIN/PWM communication circuit..... 11

**Chapter 4 MCU I/O PIN Allocation and Connector/Interface Overview..... 14**

- 4.1 S32K142 I/O pin allocation..... 14
- 4.2 Connectors..... 16

**Chapter 5 Schematic and PCB gerber file..... 21**

**Chapter 6 BOM list..... 24**

**Chapter 7 Reference..... 30**

# Chapter 1 Features

Motor control is one of the key applications for general purpose automotive MCU S32K14x and FOC is the most popular algorithm for PMSM/BLDC motor control. In order to provide user a hardware platform for motor control quick prototype verification, the MCSXTE2BK142 motor control development board has been developed.

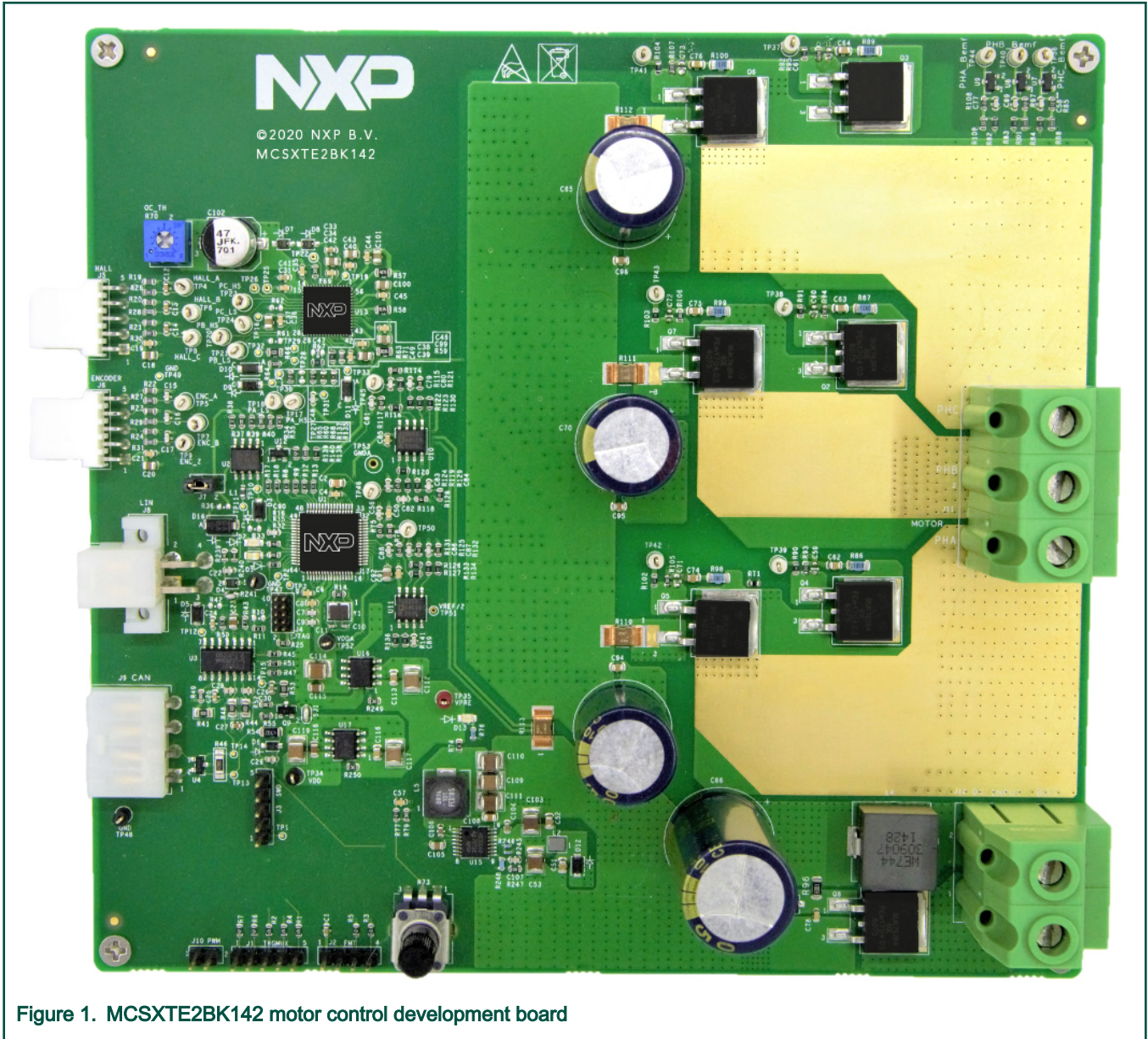

Figure 1. MCSXTE2BK142 motor control development board

This board is based on NXP S32K142 high-performance automotive-grade MCU and MC33GD3000 gate pre-driver, and provides the following features:

- Support 24 V power supply system with up to 800 W automotive BLDC/PMSM motor control system
- Drive multiple types of automotive motors and tune those motors directly
- PMSM FOC algorithm for smooth speed and torque drive
- Implement three types of current sampling solutions - single shunt, dual shunts and triple shunt

- Support multiple diagnose and protection covering UV, OV, OT, OC, Short, Stall Detection, and so on
- Support speed/control commands from LIN/CAN/PWM

The following abbreviations are used in the user guide.

**Table 1. Acronyms and abbreviations**

Abbreviations	Description
HW	Hardware
SW	Software
QSP	Quick Start Package
POR	Power-On Reset
BLDC	Brushless Direct Current Motor
PMSM	Permanent-Magnet Synchronous Motor
FOC	Field-Oriented Control
SDK	Software Development Kit

# Chapter 2

## Hardware system block diagram

The MCSXTE2BK142 is designed to deliver a motor control HW solution to support 24 V automotive system which can be used for multiple applications such as Cooling Fan, Oil Pump, Water pump or Blower, and it is an out of box evaluation board for customer of automotive motor control market.

To achieve the function features - the 12~36 V VBAT input is firstly connected an anti-reverse protection circuit and get output of VIN, then converted by the DC-DC converter to get 7 V VPRE, and last get 5 V VDD output through two LDO regulators. The VIN is directly connected to 3-phase MOSFET high side power stage and GD3000 pre-driver to provide power for motor control, the VDD is used by S32K142 MCU and TJA1043T CAN transceiver. For debug purpose, a SWD debug port is reserved for program download and debug. TTL UART communication interface is provided for FreeMASTER/MCAT communication and a 5-pin connector is routed with TRIGMUX signal for FOC trigger monitor. Besides, a hall sensor and an encoder interface are designed for sensor based FOC motor control A signal conditional and PGA circuit are used to sample the 3-phase currents and back-electromotive force for Sensorless FOC. One CAN bus and one LIN bus as well as a high voltage PWM input interface are designed for external connectivity extension, such as user motor control (rotation direction, speed) command input and motor diagnostic information feedback.

The following is the board hardware system block diagram.

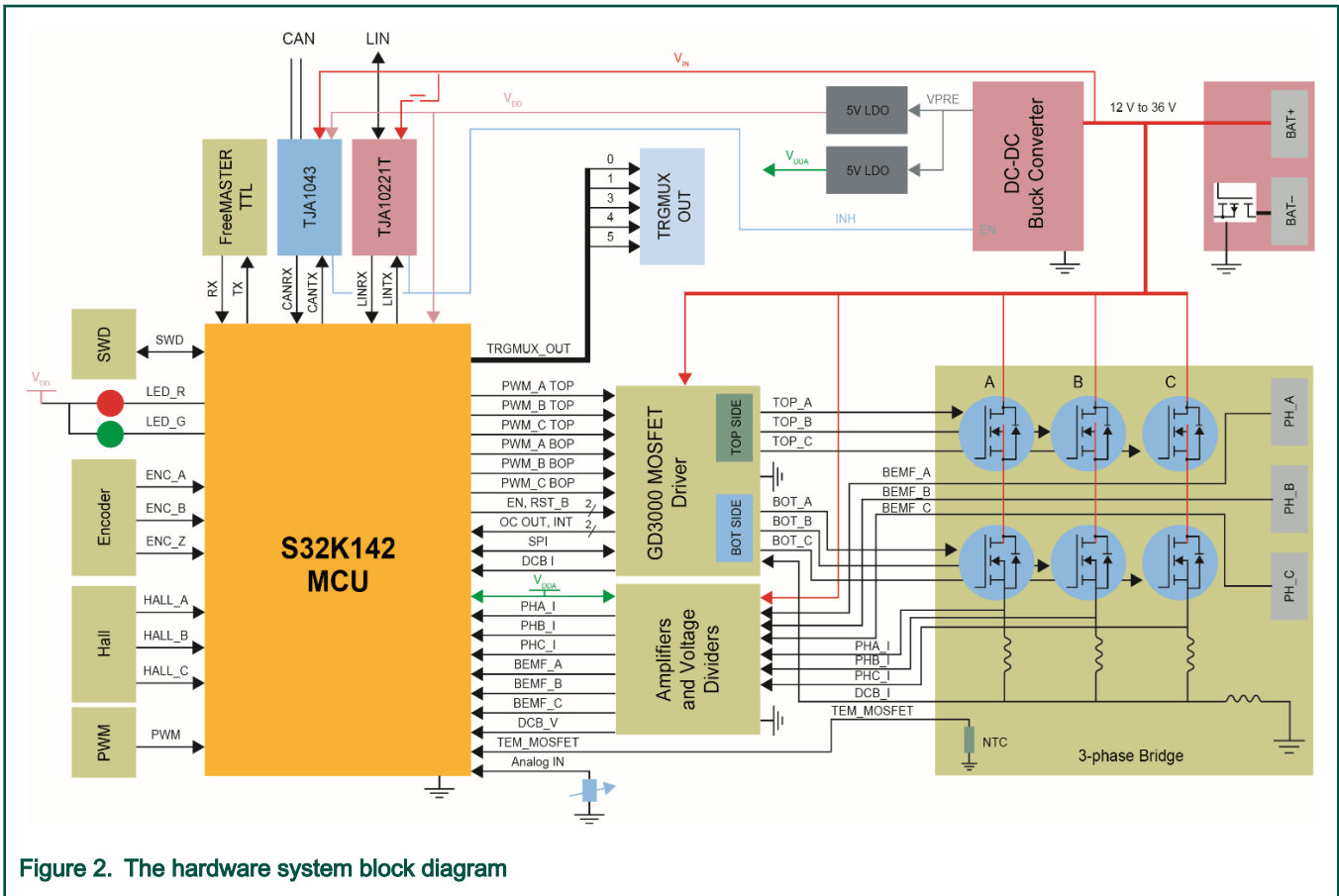

Figure 2. The hardware system block diagram

The main devices used in the board are:

- S32K142: the main microcontroller with ARM® Cortex® M4F high-performance CPU core, 16 region MPU, 16-channel eDMA, 32 KB SRAM and 256 KB P-Flash as well as 4 KB emulated EEPROM all with ECC, 4x16-bit Flextimer, PDB, TRIGMUX and 2x12-bit SAR ADC for motor control application
- MC33GD3000: Three-phase field effect transistor pre-driver

- TJA1043T: High-speed CAN transceiver
- TJA1021T: LIN transceiver
- BUK762R4-60E: N-channel TrenchMOS standard level FET
- MC33375: LDO regulator, 300 mA, High PSRR, with On/Off control
- LM46000: 3.5 - 60 V, 500 mA synchronous Step-Down voltage converter

# Chapter 3

## The Board Sub-module Function Circuit Design Details

The board hardware sub-module function circuit design details will be described in this chapter.

### 3.1 Power supply circuit

To support the 24 V power supply, select a high-current connector for the 10~36 V DC VBAT input. Then the N-MOSFET(BUK762R4-60E) based active reverse battery protection circuit is applied before producing the VIN. Considering the power supply stability, a 2200 uF bulk capacitor is used o VIN.

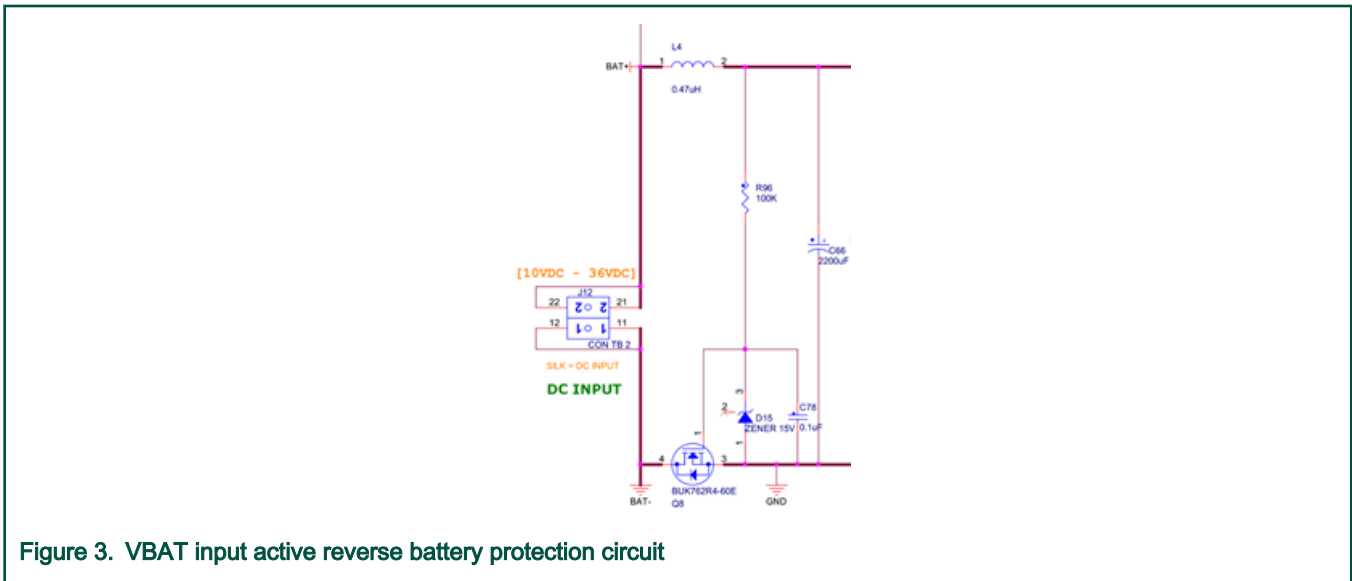

The VIN is then input to a 500 mA Synchronous Step-Down Voltage Converter (LM46000) for generate a 7 V VPRE.

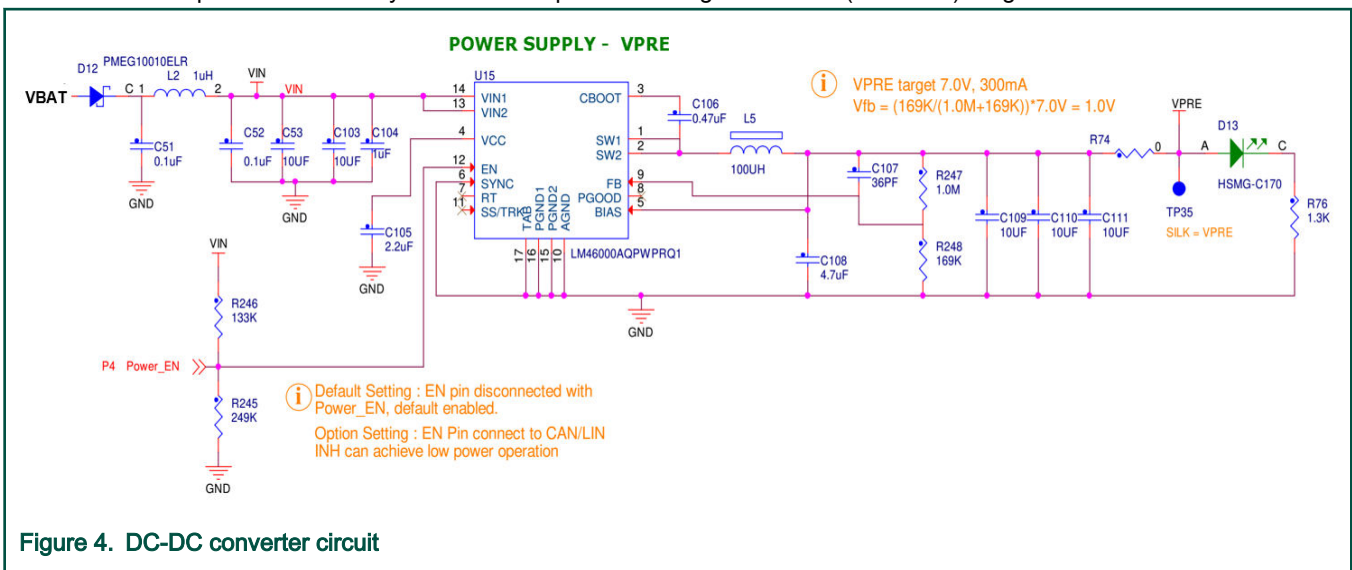

The 7 V VPRE is used as two LDO(MC33375) input to generate 5 V VDDA and VDD. The VDDA is used for S32K142 on-chip analog module (ADC and AMP) and analog signal condition reference voltage, while VDD is used for S32K142 MCU and digital peripherals as well as CAN transceiver power supply. The analog ground(GNDA) and digital ground(GND) is single point connected via a 0Ω resistor. Such a power topology can naturally isolate the analog and digital circuit and reduce interference effectively.



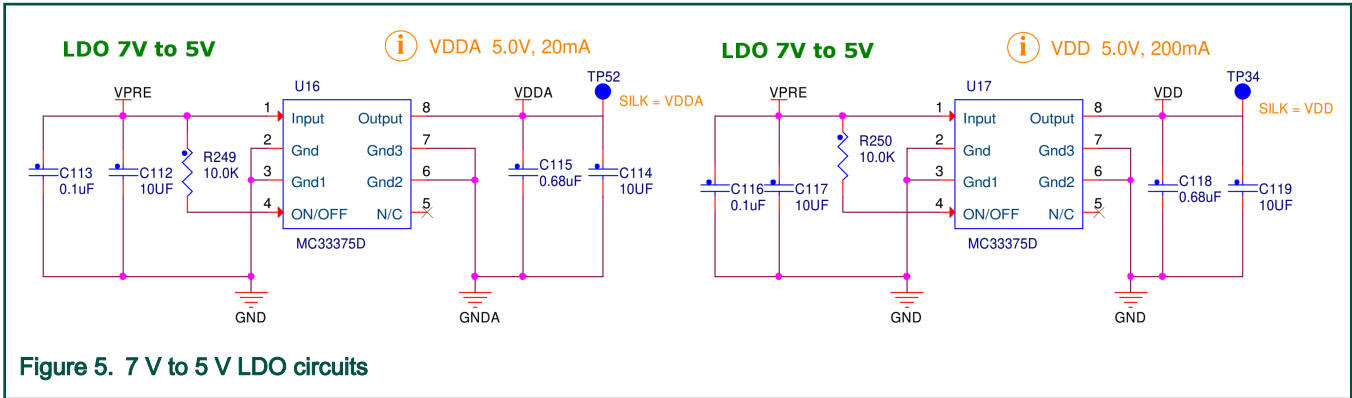

### 3.2 MCU circuit

For S32K142 MCU, refer to its hardware design guide , add a 0.1 uF bypass capacitor for each VDD and VDDA pin, and place these capacitors as close as possible to the MCU pin, besides, a 4.7 uF bulk capacitor is used on the VDD to keep its ramp rate within the MCU datasheet requirement. Two 1 nF filter capacitors are added on VDDA to absorb the high-frequency noise.

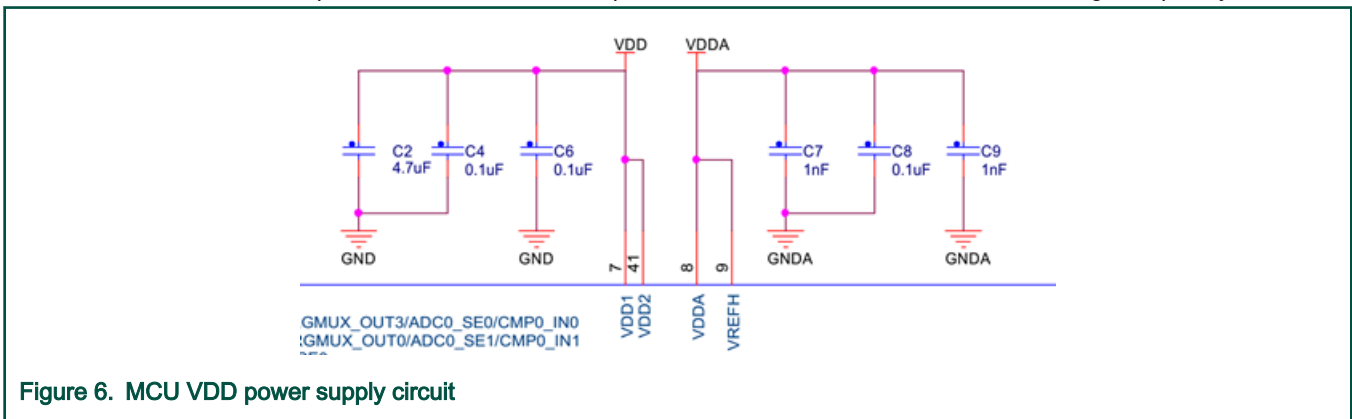

A 8 MHz crystal is used as the MCU PLL and CAN controller reference clock.

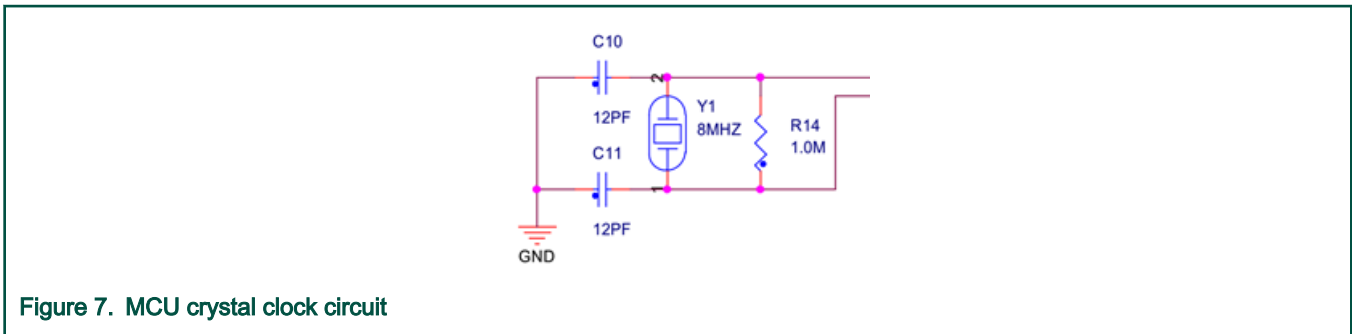

Two LEDs (one red and one green) are connected to PTE0 and PTE1 for motor status indication, a 680Ω serial current limitation resistor is used for each LED circuit, the LED will be turned on when PTE0/1 output low(logic 0).

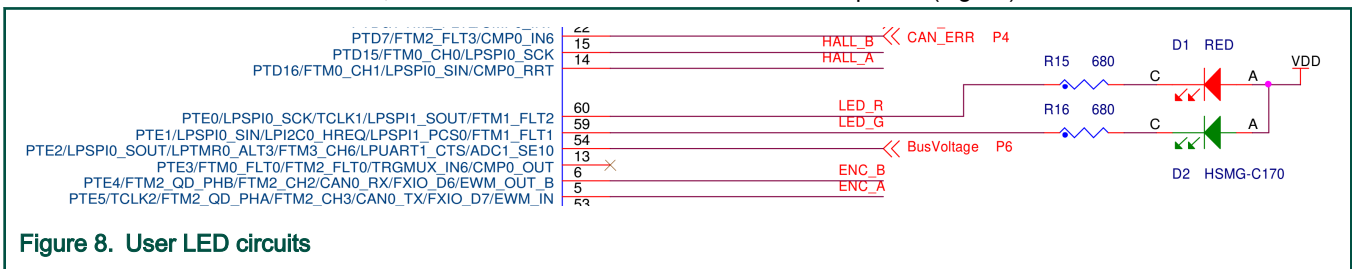



Other MCU function (include 3-phase PWM output, GD3000 pre-driver SPI, phase current sample ADC input, hall and encoder input as well as CAN and LIN interfaces, and TRIGMUX routing) pins are allocated as below, details can be referred to [S32K142 I/O pin allocation](#).

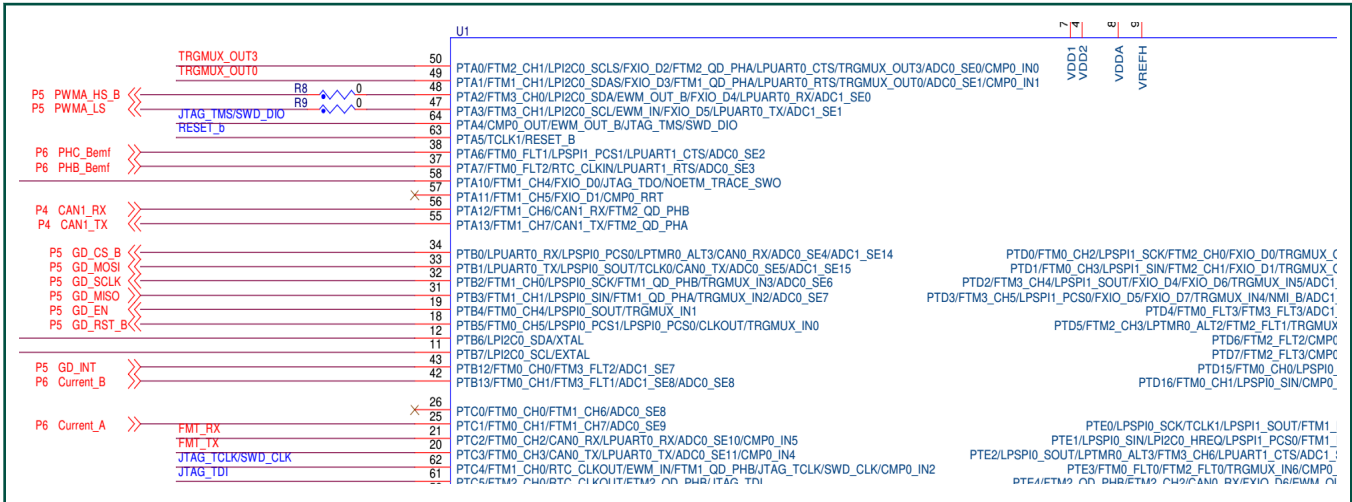
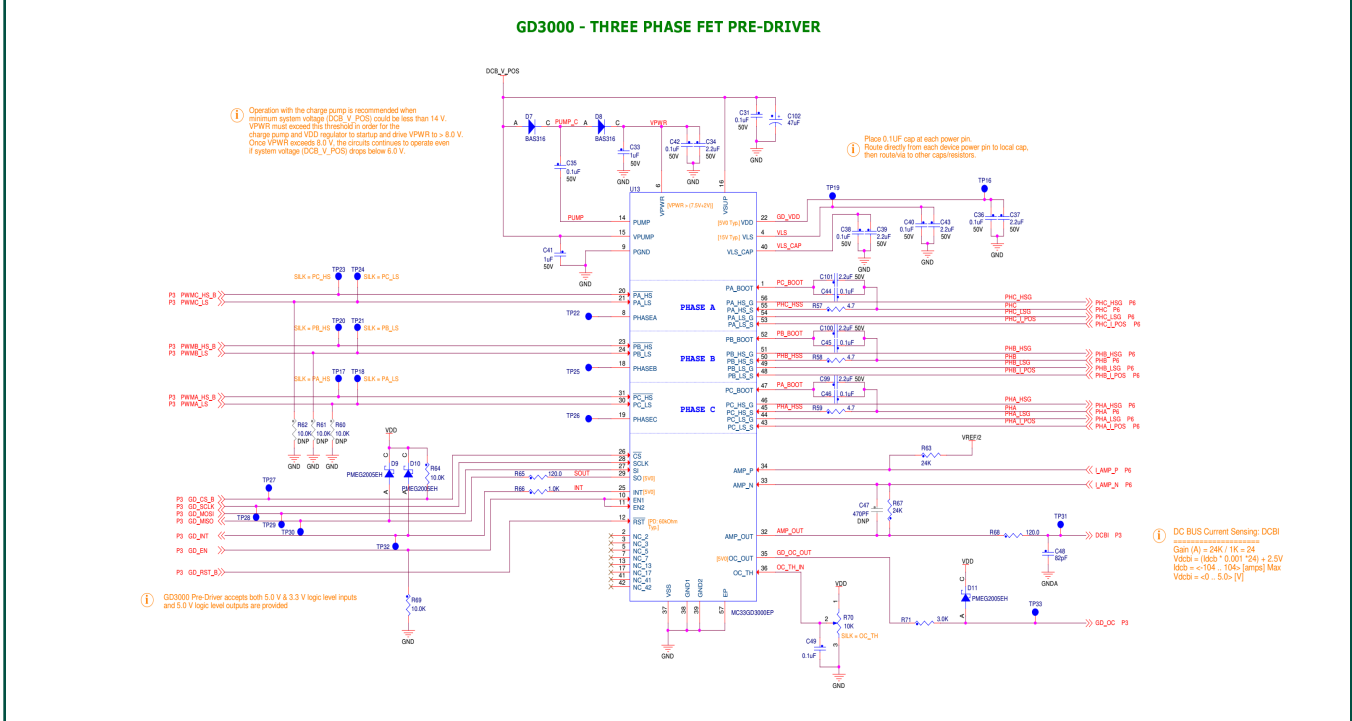

Figure 9. Other MCU function circuit

### 3.3 Gate driver circuit

This design selects NXP MC33GD3000 as the 3-phase gate pre-driver. The S32K142 FlexTimer generated six channel PWM outputs are connected to MC33GD3000 in three phases. HS (High Side) and LS (Low Side) IN, one enable (EN) and reset (RST) control signal from S32K142 to enable, and reset the pre-driver. One interrupt (INT) as event feedback to S32K142 is needed for the motor control. Besides, a SPI interface is used to configure the MC33GD3000 and readback real-time diagnostic registers.

Figure 10. MC33GD3000 3-phase gate pre-driver circuit



A 10 KΩ potentiometer(R70) is used to adjust the MC33GD3000 over current detector threshold, and the pre-driver integrated I-sense amplifier is used for MOSFET power stage DC bus current (DCBI) sampling.

Figure 11. MC33GD3000 OC and DCBI sample circuit

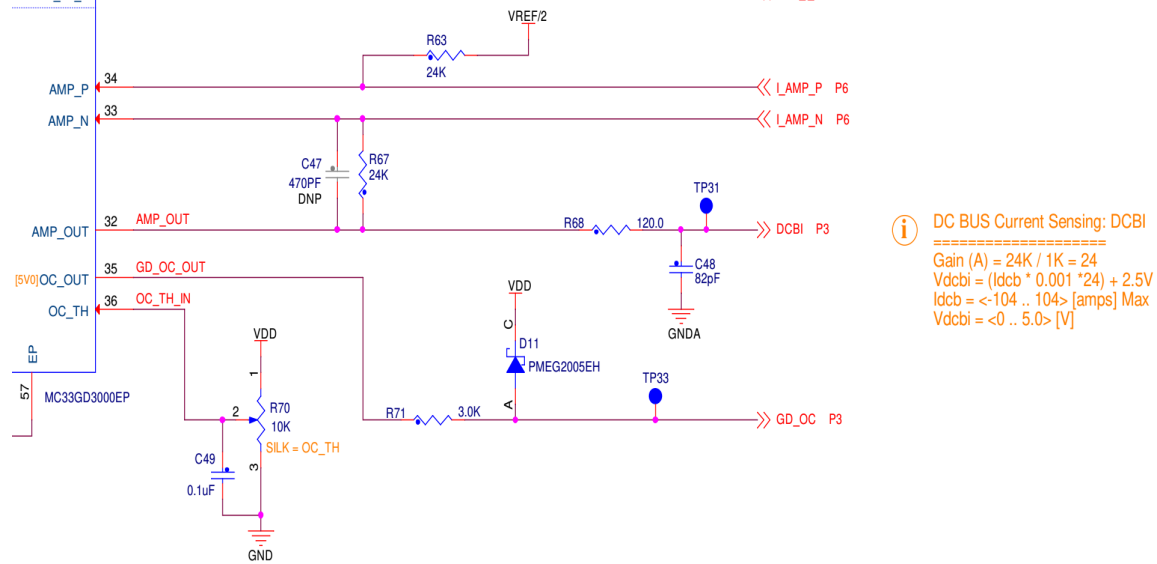

### 3.4 Power stage and signal condition circuit

Six N-channel MOSFET(BUK762R4-60E) are used to construct three half-bridge power stage for 3-phase motor control.

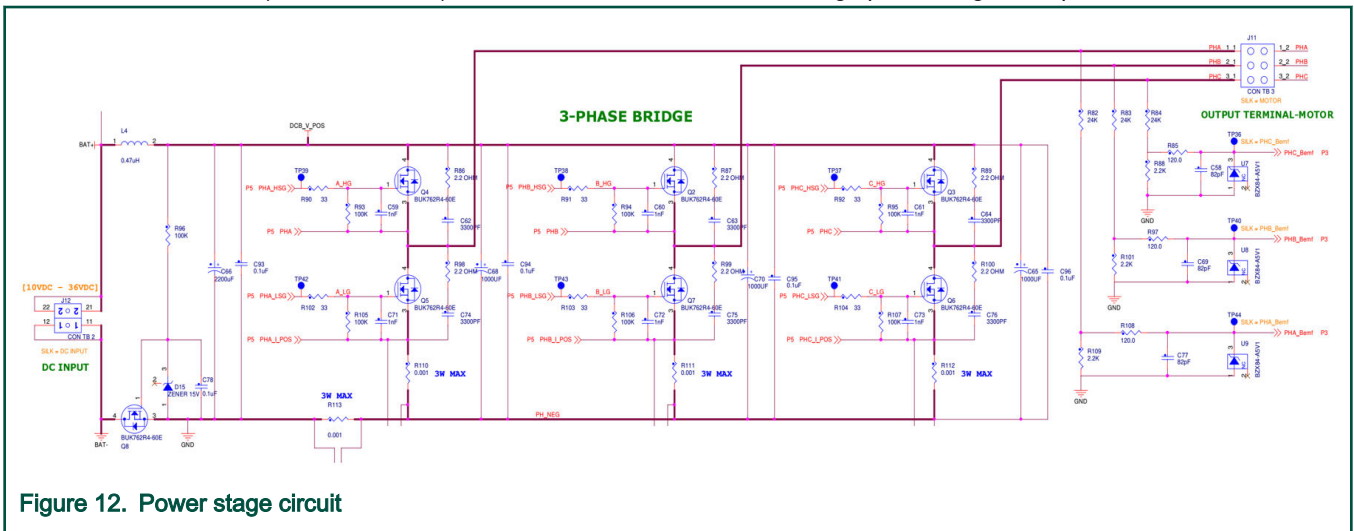

Figure 12. Power stage circuit

Three 1 mΩ shunt resistors (R110~R112) are used for phase current sample. Three phase back-electromotor force voltage sample circuits are also developed for sensorless FOC PMSM and BLDC motor control.

The phase current voltage signals are very small, so two AD8656 (dual channel differential input Low Noise, Precision CMOS Amplifier) are used to amplify these small signals by approximately twenty times.

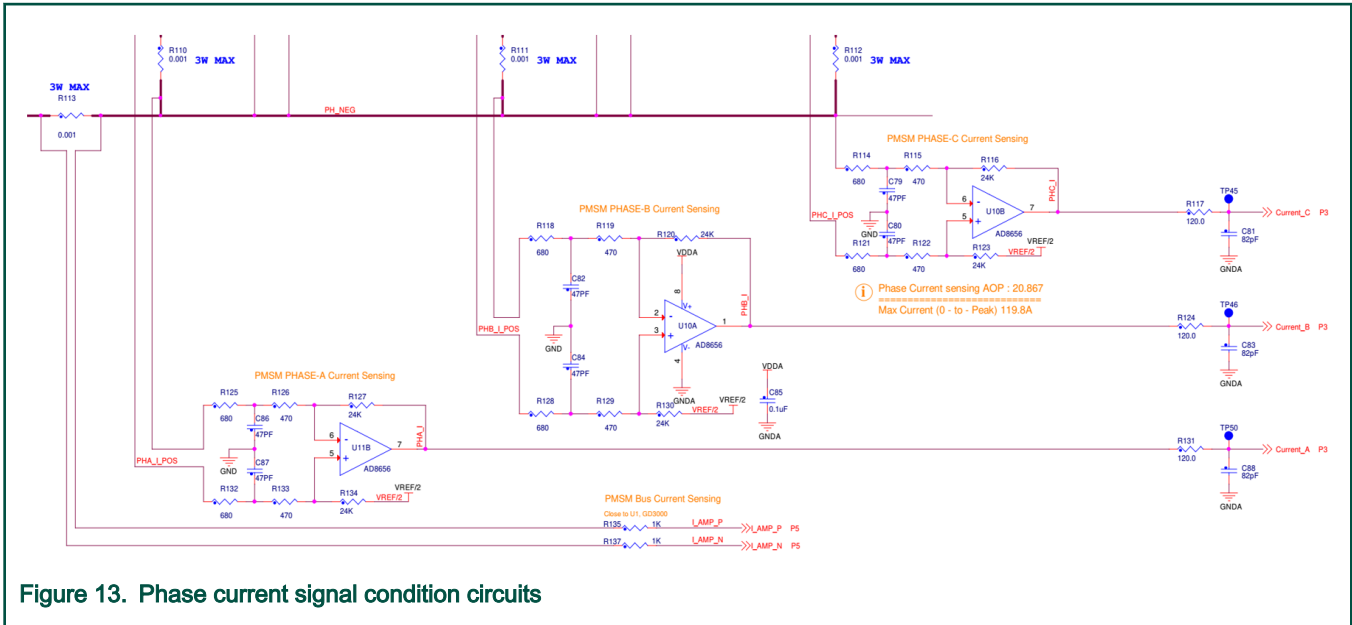

Figure 13. Phase current signal condition circuits

The phase current amplifiers require a 2.5 V reference voltage which is produced by one of the four amplifiers working in following mode via a 1/2 VDDA divider circuit.

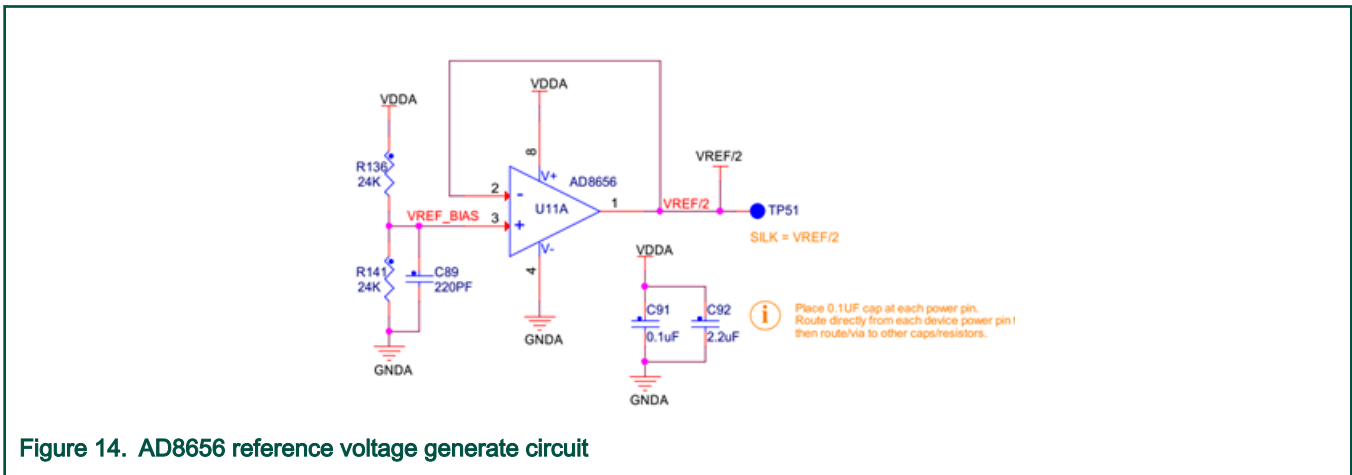

Figure 14. AD8656 reference voltage generate circuit

Besides, for temperature protection, a NTC thermistor (RT1) is designed and placed closely to the six N-MOSFET to acquire the real-time power stage temperature. The DC-bus voltage required by motor control algorithm is divided by R138 and R140 and then sampled and converted by S32K142 ADC channel.

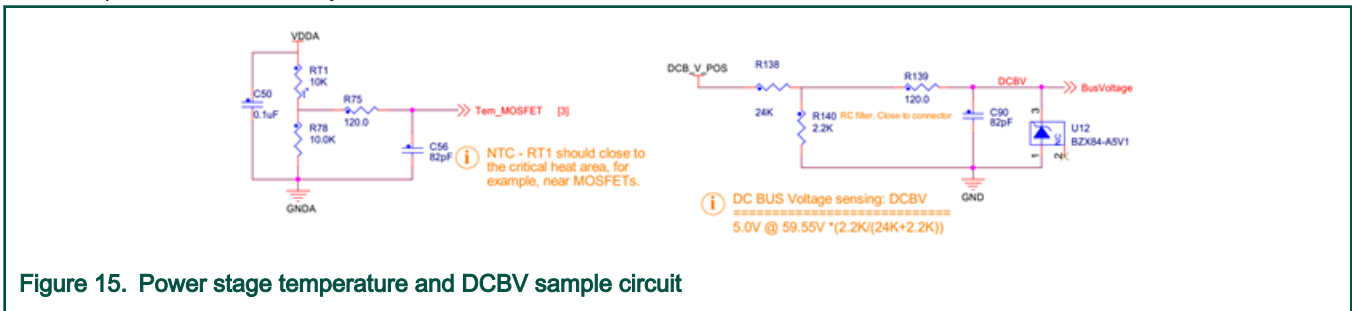

Figure 15. Power stage temperature and DCBV sample circuit

### 3.5 CAN/LIN/PWM communication circuit

To receive the motor control command, such as motor rotation direction and speed requirement, and return the motor status and diagnostic information from/to external ECU, the board supports CAN, LIN and PWM communication.

The control pins from S32K142 are used to enable (CAN\_EN, active high) and standby lowpower mode (CAN\_STB, active low).

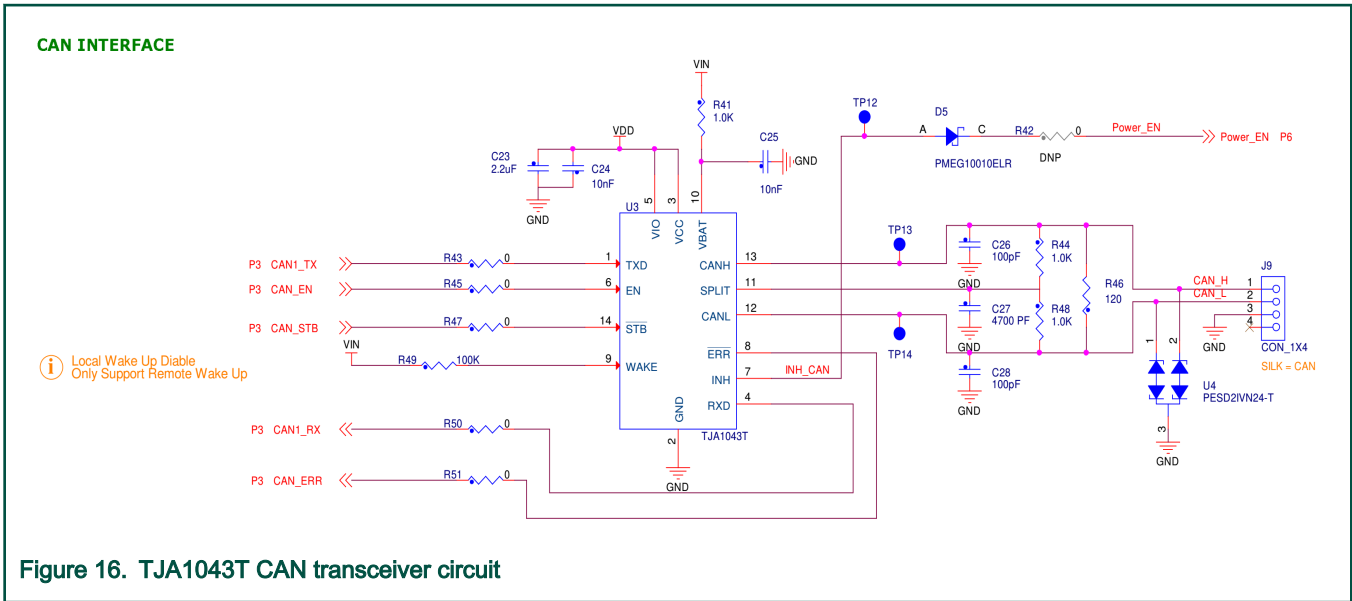

Figure 16. TJA1043T CAN transceiver circuit

**NOTE**

User must control S32K142 to output high level on both CAN\_EN and CAN\_STB to make the TJA1043T transceiver working in normal mode before starting any CAN message transmit and receive.

For LIN communication, TJA1021T is used as the LIN transceiver. A sleep control (LIN\_SLP, active low) pin from S32K142 is used for low-power control.

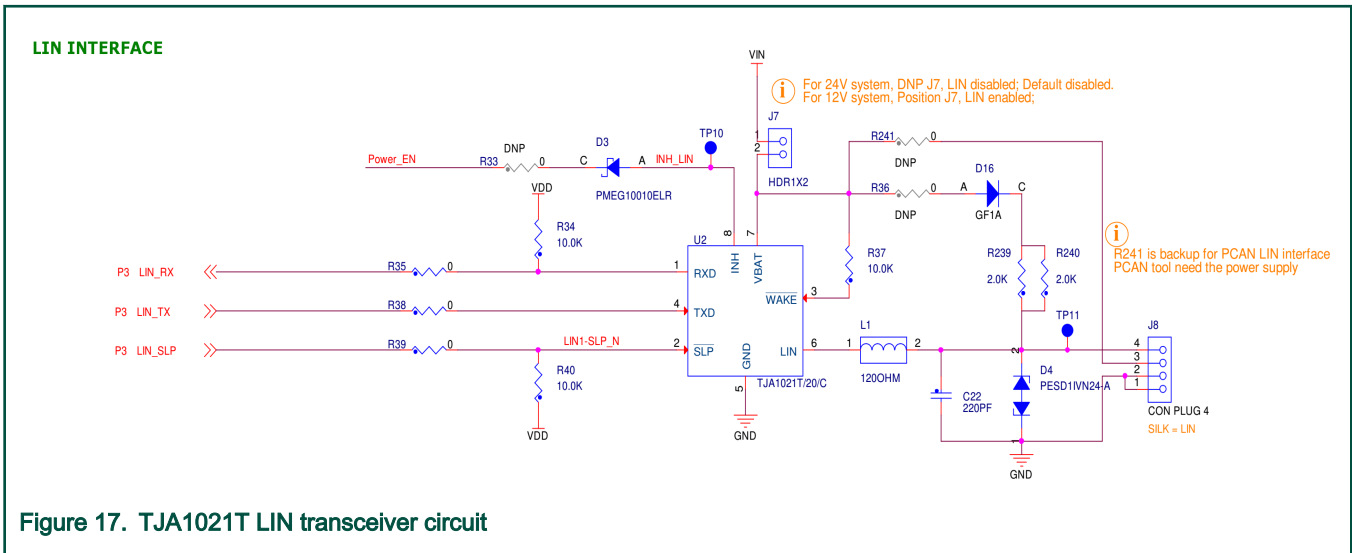

Figure 17. TJA1021T LIN transceiver circuit

**NOTE**

- User must control S32K142 to output high level on LIN\_SLP to make the TJA1021T transceiver entering in normal mode before starting any LIN message transmit and receive.
- VIN is the power supply for the TJA1021T LIN transceiver, it's enabled by J7, which is not connected by default for 24 V/12 compatibility, user should short J7 with a jumper before using LIN bus.
- If user wants to get VBAT output from the board for other LIN node, such a USB to LIN device (for example the PEAK LIN), user must solder the 0Ω resistor — R241, which is not assembled by default.

For some low-cost motor control applications, customer prefers to use the PWM communication as control command input, to facilitate such application assessment, the board also have a high-voltage input circuit, which is connected to one of S32K142 FlexTimer input capture channels.

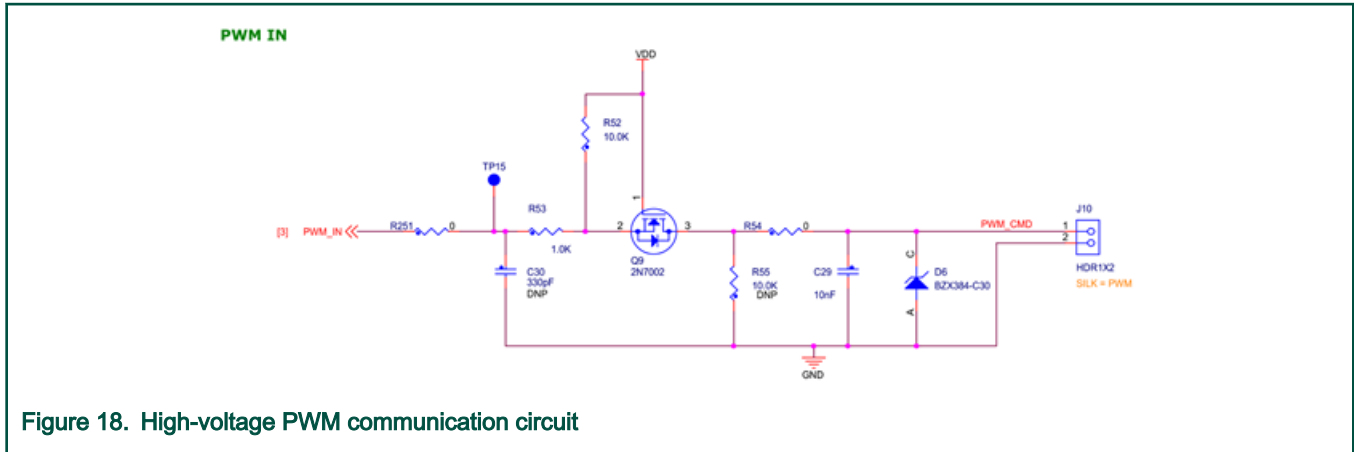

Figure 18. High-voltage PWM communication circuit

**NOTE**

The acceptable PWM input signal voltage range is VDD ~ VBAT, and recommended frequency is 20 HZ ~ 1 KHZ, for high frequency signal measurement will occupy more CPU interrupt and affect FOC calculation.

Besides, A 10K potentiometer(R73) is connected to S32K142 ADC input and used for motor speed control without CAN/LIN/PWM communication.

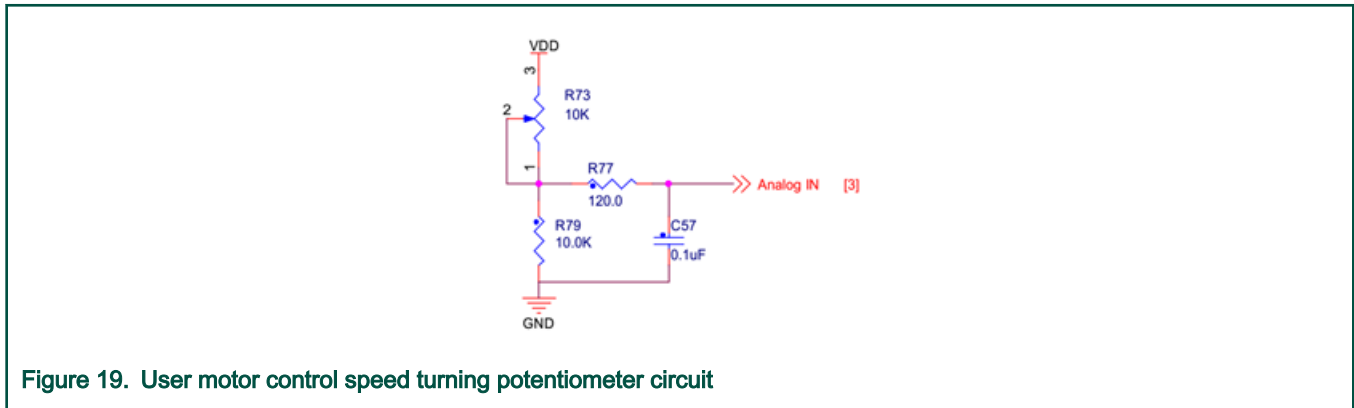

Figure 19. User motor control speed turning potentiometer circuit

# Chapter 4

## MCU I/O PIN Allocation and Connector/Interface Overview

The S32K142 pin function map and allocation details are given out in this chapter.

### 4.1 S32K142 I/O pin allocation

The board used S32K142 peripherals and I/O pin mapping is as below table, it can be used for S32K1xx SDK `pin_mux` component configuration in S32DS IDE Processor Expert:

**Table 2. S32K142 I/O pin mapping for the board**

S32K142 peripheral module	Board Function	Peripheral Function	GPIO pin
TRGMUX_OUT	TRGMUX_OUT0	TRGMUX_OUT0	PTA1
	TRGMUX_OUT1	TRGMUX_OUT1	PTD0
	TRGMUX_OUT3	TRGMUX_OUT3	PTA0
	TRGMUX_OUT4	TRGMUX_OUT4	PTE10
	TRGMUX_OUT5	TRGMUX_OUT5	PTE11
PWM	PWMA_HS_B	FTM3_CH0	PTA2
	PWMA_LS	FTM3_CH1	PTA3
	PWMB_HS_B	FTM3_CH2	PTC6
	PWMB_LS	FTM3_CH3	PTC7
	PWMC_HS_B	FTM3_CH4	PTD2
	PWMA_LS	FTM3_CH5	PTD3
SPI	GD_CS_B	LPSPi0_PCS0	PTB0
	GD_MOSI	LPSPi0_SOUT	PTB1
	GD_SCLK	LPSPi0_SCK	PTB2
	GD_MISO	LPSPi0_SIN	PTB3
CAN	CAN1_RX	CAN1_RX	PTA12
	CAN1_TX	CAN1_TX	PTA13
	CAN_EN	GPIO_O	PTD5
	CAN_STB	GPIO_O	PTD6

*Table continues on the next page...*

**Table 2. S32K142 I/O pin mapping for the board (continued)**

	CAN_ERR	GPIO_I	PTD7
ADC	PHA_I	ADC0_SE9	PTC1
	PHB_I	ADC1_SE8/ADC0_SE8	PTB13
	PHC_I	ADC1_SE6	PTD4
	DCB_I	ADC0_SE15	PTC17
	DCB_V	ADC1_SE10	PTE2
	BEMF_A	ADC0_SE12	PTC14
	BEMF_B	ADC0_SE3	PTA7
	BEMF_C	ADC0_SE2	PTA6
	Tem_MOSFET	ADC0_SE13	PTC15
	Analog_IN	ADC0_SE14	PTC16
LIN	LIN_RX	LPUART1_RX	PTC8
	LIN_TX	LPUART1_TX	PTC9
	LIN_SLP	GPIO_O	PTE8
LPUART	FMT_RX	LPUART0_RX	PTC2
	FMT_TX	LPUART0_TX	PTC3
FTM	HALL_A	FTM0_CH1	PTD16
	HALL_B	FTM0_CH0	PTD15
	HALL_C	FTM0_CH7	PTE9
	ENC_A	FTM2_QD_PHA	PTE5
	ENC_B	FTM2_QD_PHB	PTE4
	ENC_Z	FTM2_CH1	PTD1
	PWM_IN	FTM1_CH4	PTA10
GPIO	GD_EN	GPIO_O	PTB4
	GD_RST_B	GPIO_O	PTB5
	GD_OC	GPIO_I	PTE7

*Table continues on the next page...*



**Table 2. S32K142 I/O pin mapping for the board (continued)**

	GD_INT	GPIO_I	PTB12
	LED_R	GPIO_O	PTE0
	LED_G	GPIO_O	PTE1

**NOTE**

The phase B current (**PHB\_I**) is assigned to PTB13, which is shared between ADC0 and ADC1 channel 8 (**ADC1\_SE8/ADC0\_SE8**) as the interleave function, it should be carefully configured for dual-shunt/tri-shunt phase current sample in the motor control application.

### 4.2 Connectors

The board connector functions and pins allocation are described in this chapter.

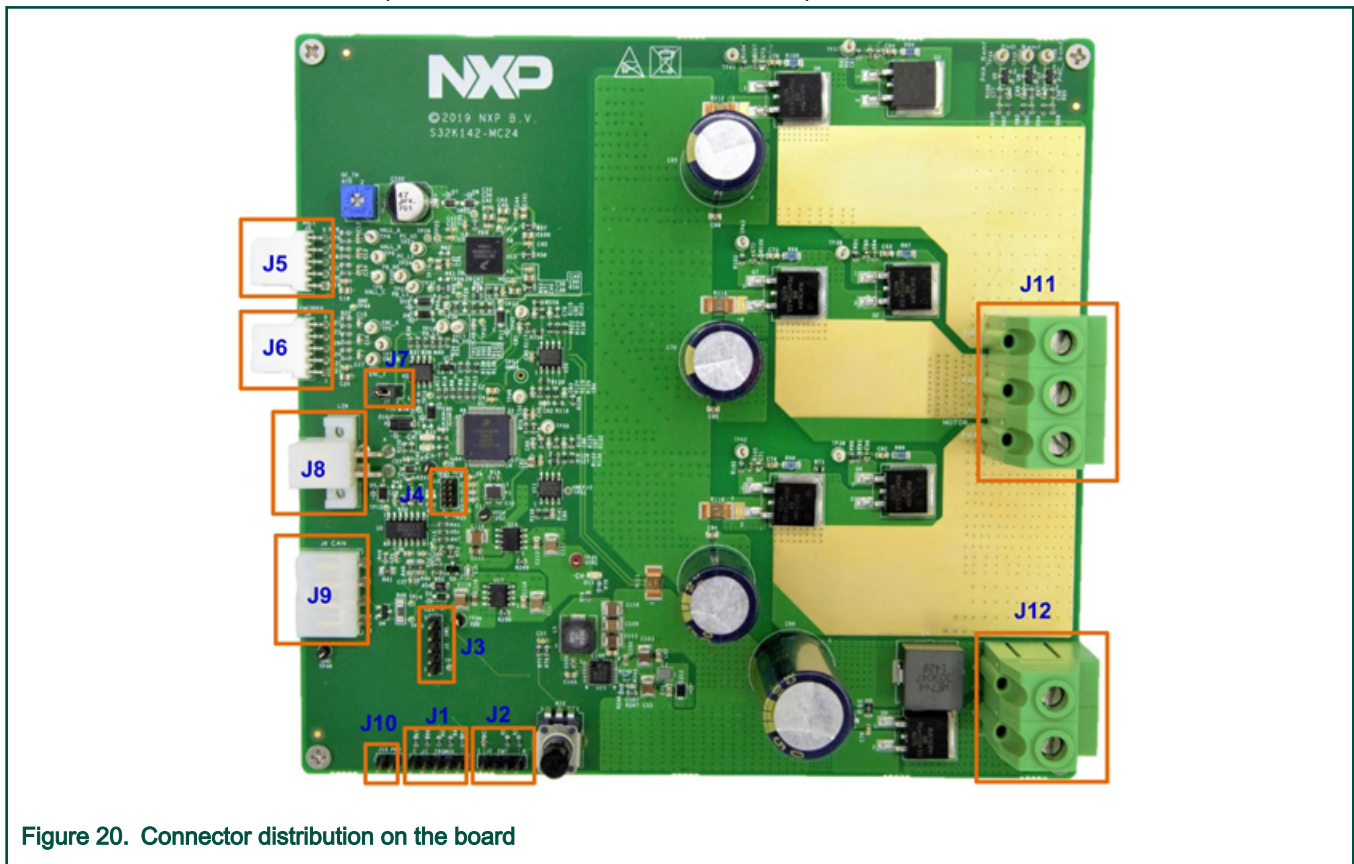

**Figure 20. Connector distribution on the board**

Power input connector, the board is designed to be compatible with 24 V system, so the allowed VBAT input voltage range is - 10 VDC to 36 VDC, outside the voltage input, the board may be damaged or not work - the performance is not guaranteed.

**Table 3. Power supply connector**

Connector	pin	function
J12	J12-1	VBAT-
	J12-2	VBAT+

3-phase motor connector:

**Table 4. 3-phase motor connector**

Connector	pin	function
<b>J11</b>	J11-1	PHA
	J11-2	PHB
	J11-3	PHC

TRGMUX OUT connector:

**Table 5. TRGMUX out connector**

Connector	pin	function
<b>J1</b>	J1-1	TRGMUX_OUT5
	J1-2	TRGMUX_OUT4
	J1-3	TRGMUX_OUT3
	J1-4	TRGMUX_OUT1
	J1-5	TRGMUX_OUT0

Debug interface connector, the board debugger port is routed to both J3(a 100mil pitch 1x5 header for J-LINK customized connection) and J4(a standard min-10 pin ARM debugger connector for U-Multilink/FX, Lauterbach, iSystem debugger). **J3 supports only SWD, while J4 supports both SWD and JTAG.**

**Table 6. Debugger connector**

Connector	pin	function
<b>J3</b>	J3-1	VDD
	J3-2	SWD_DIO
	J3-3	SWD_SCLK
	J3-4	GND
	J3-5	RESET_b
<b>J4</b>	J4-1	VDD
	J4-2	JTAG_TMS/SWD_DIO
	J4-3	GND
	J4-4	JTAG_TCLK/SWD_CLK
	J4-5	GND

*Table continues on the next page...*

**Table 6. Debugger connector (continued)**

	J4-6	JTAG_TDO
	J4-7	NC
	J4-8	JTAG_TDI
	J4-9	NC
	J4-10	RESET_b

Hall sensor connector:

**Table 7. Hall sensor connector**

Connector	pin	function
<b>J5</b>	J5-1	VDD
	J5-2	GND
	J5-3	HALL_C
	J5-4	HALL_B
	J5-5	HALL_A

Encoder connector:

**Table 8. Encoder connector**

Connector	pin	function
<b>J6</b>	J6-1	VDD
	J6-2	GND
	J6-3	ENC_C
	J6-4	ENC_B
	J6-5	ENC_A

FreeMASTER UART TTL communication connector:

**Table 9. FreeMASTER UART TTL connector**

Connector	pin	function
<b>J2</b>	J2-1	VDD
	J2-2	GND

*Table continues on the next page...*

**Table 9. FreeMASTER UART TTL connector (continued)**

	J2-3	UART_TX
	J2-4	UART_RX

CAN communication connector:

**Table 10. CAN communication connector**

Connector	pin	function
<b>J9</b>	J9-1	CAN_H
	J9-2	CAN_L
	J9-3	GND
	J9-4	NC

LIN communication connector:

**Table 11. LIN communication connector**

Connector	pin	function
<b>J7<sup>1</sup></b> (TJA1021 power supply)	J7-1	VIN
	J7-2	VBAT of TJA1021
<b>J8</b>	J8-1	GND
	J8-2	GND
	J8-3	VBAT <sup>2</sup>
	J8-4	LIN

**NOTE**

- For the board can support 24 V system, while TJA1021 is only adapt to 12 V system, so the **J7** header is open by default, it can be close for 12 V VBAT as power supply only.
- If user wants to get VBAT output from the board for other LIN node, such a USB to LIN device (e.g. the PEAK LIN), user must solder the 0Ωresistor — R241, which is not assembled by default.

PWM communication connector:

**Table 12. PWM communication connector**

Connector	pin	function
<b>J10</b>	J10-1 <sup>1</sup>	PWM_CMD
	J10-2	GND

---

**NOTE**

The acceptable PWM input signal voltage range is: +8 V ~ +30 V.

---

# Chapter 5

## Schematic and PCB gerber file

The completed schematic and PCB gerber files of the board are included in the QSP (Quick Start Package), user can download it from the board official product website from [www.nxp.com/MCSXTE2BK142](http://www.nxp.com/MCSXTE2BK142).

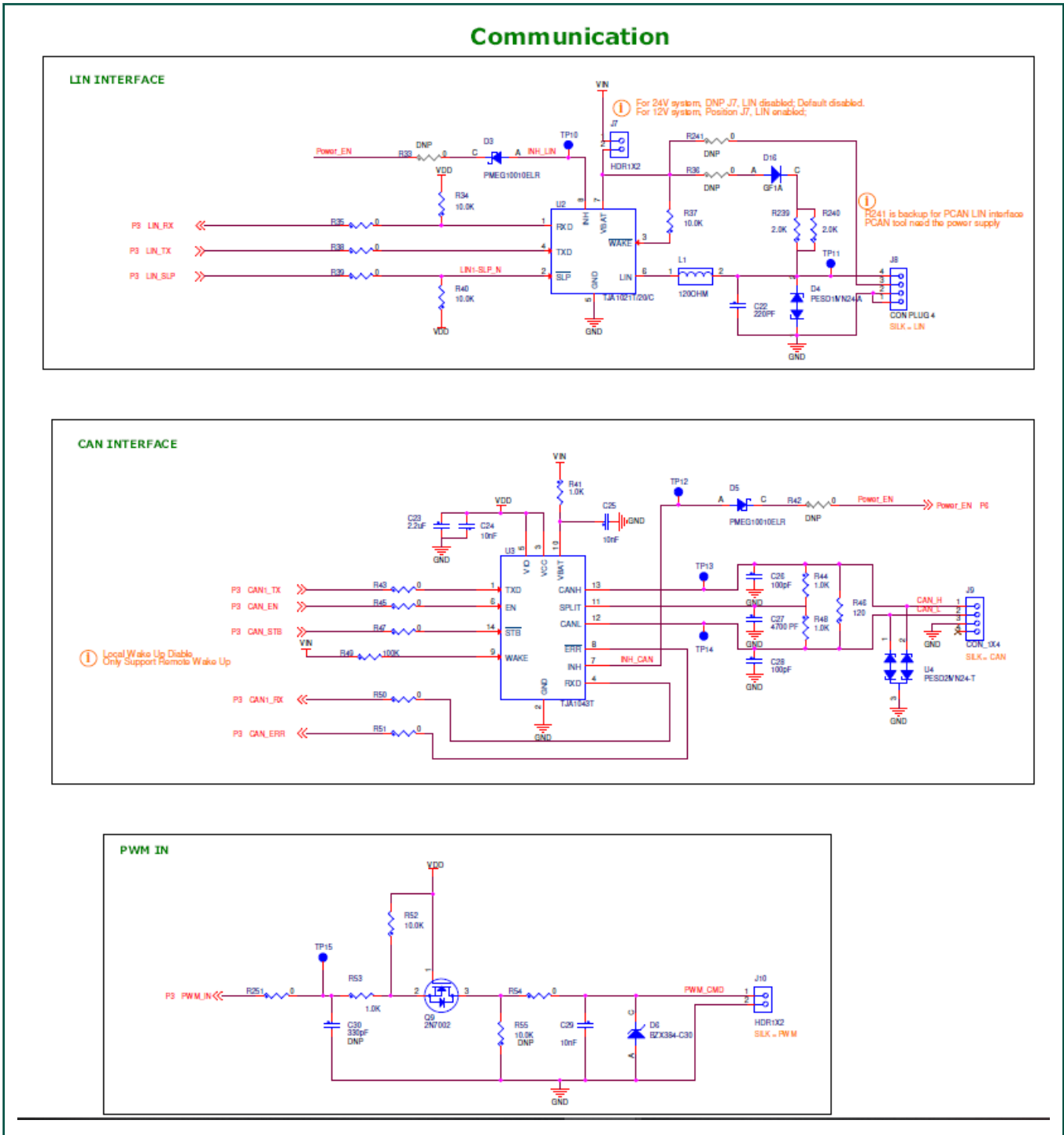

### S32K142 - Microcontroller

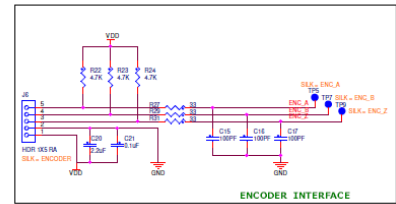
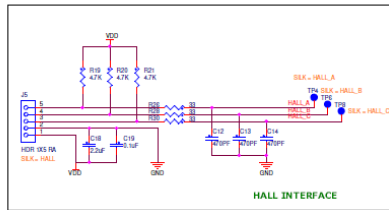
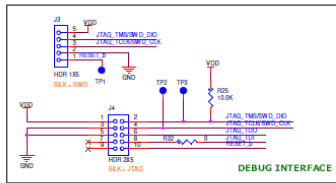
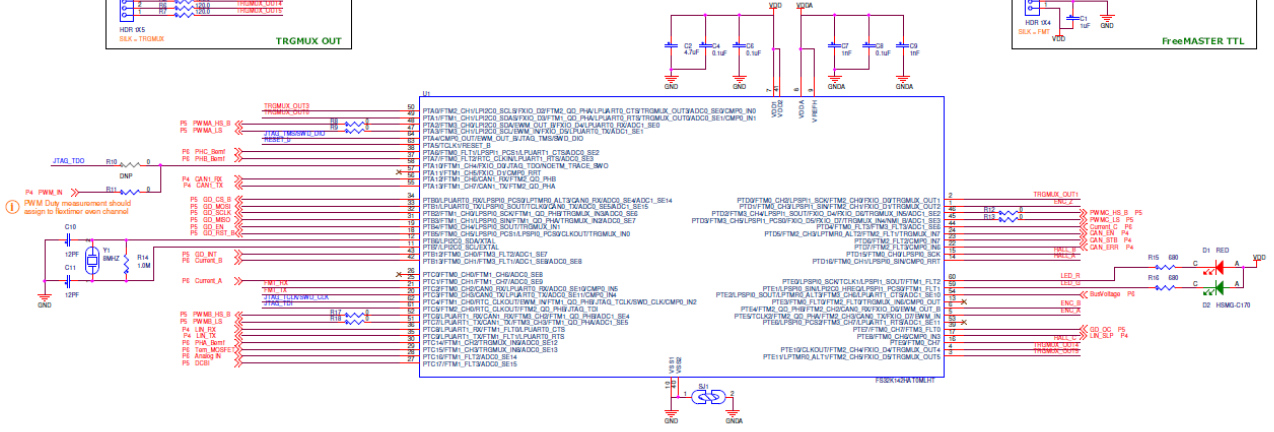
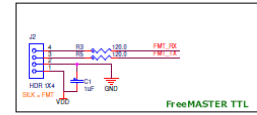
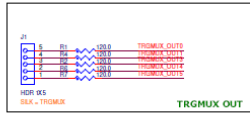

### GD3000 - THREE PHASE FET PRE-DRIVER

Operation with the charge pump is recommended when maximum system voltage (DCB\_V\_PSD) could be less than 14 V. VPMR must exceed this threshold in order for the charge pump and VDD regulator to start and drive VPMR > 8.0 V. Once VPMR exceeds 8.0 V, the circuit continues to operate even if system voltage (DCB\_V\_PSD) drops below 8.0 V.

Place 0.1 uF cap at each power pin. Route directly from each device power pin to local cap, then route via to other capacitors.

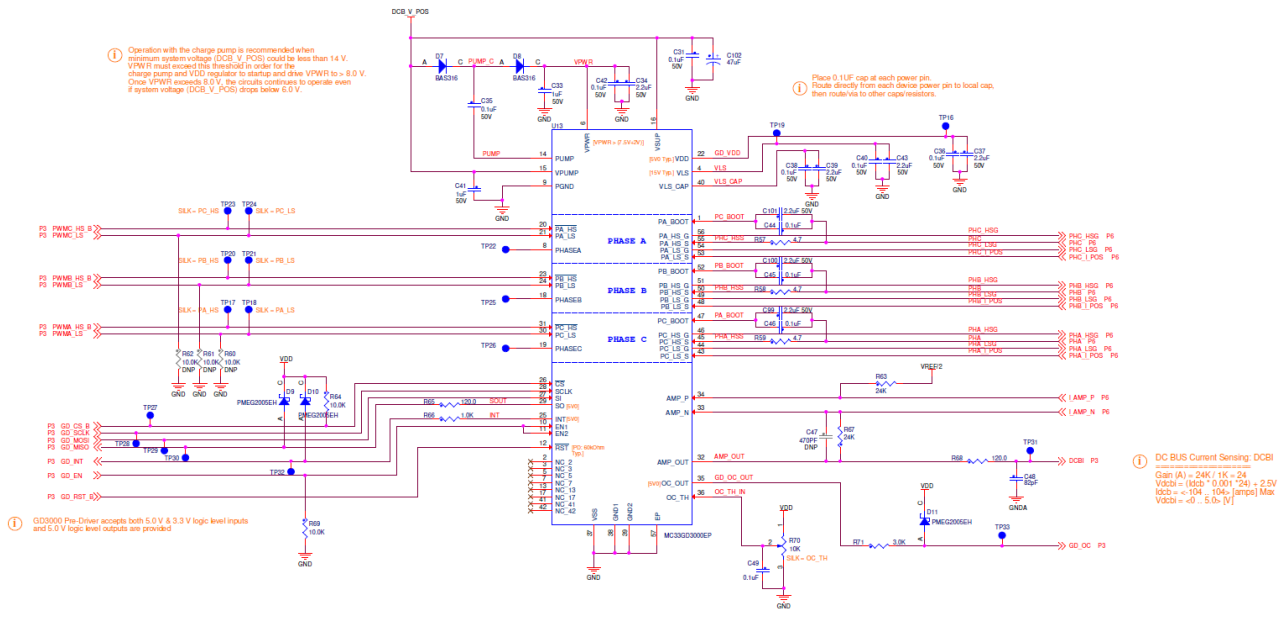



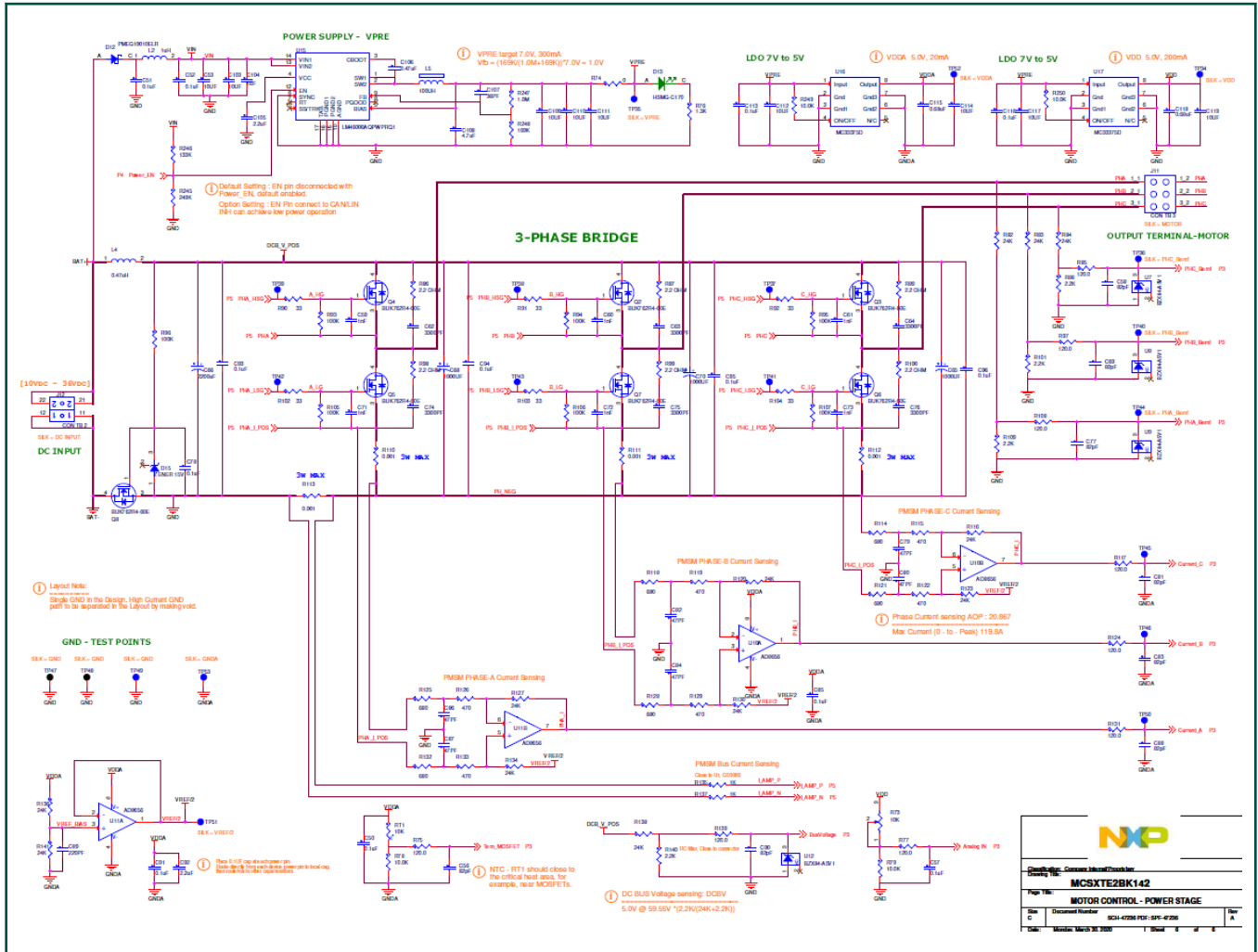

## Chapter 6

# BOM list

The BOM list of this board is as below:

**Table 13. BOM list**

Part reference	Quantity	Value	DESCRIPTION	Manufacturer
C1,C33,C41,C104	4	1uF	CAP CER 1uF 50V 10% X5R AEC-Q200 0603	TDK
C2,C108	2	4.7uF	CAP CER 4.7uF 16V 10% X7R AEC-Q200 0805	TDK
C4,C6,C8,C19,C21,C31,C35,C36,C38,C40,C42,C44,C45,C46,C49,C50,C57,C78,C85,C91	20	0.1uF	CAP CER 0.1uF 50V 10% X7R AEC-Q200 0603	AVX
C7,C9,C59,C60,C61,C71,C72,C73	8	1nF	CAP CER 1000PF 25V 1% C0G 0603	AVX
C10,C11	2	12PF	CAP CER 12PF 50V 5% C0G 0402	NIC COMPONENTS CORP
C12,C13,C14	3	470PF	CAP CER 470PF 50V 10% X7R 0603	AVX
C15,C16,C17	3	100PF	CAP CER 100PF 25V 10% C0G 0603	AVX
C18,C20,C23,C34,C37,C39,C43,C92,C99,C100,C101,C105	12	2.2uF	CAP CER 2.2UF 50V 10% X7R 0805	TAIYO YUDEN
C22,C89	2	220PF	CAP CER 220PF 50V 5% C0G 0603	AVX
C24,C25,C29	3	10nF	CAP CER 0.01UF 50V 5% X7R 0603	AVX
C26,C28	2	100pF	CAP CER 100pF 250V 5% C0G 0603	AMERICAN TECHNICAL CERAMICS
C27	1	4700 PF	CAP CER 4700PF 50V 5% X7R 0603	AVX
C30	1	330pF	CAP CER 330pF 25V 10% X7R 0603	YAGEO AMERICA
C47	1	470PF	CAP CER 470PF 50V 10% X7R 0603	AVX
C48,C56,C58,C69,C77,C81,C83,C88,C90	9	82pF	CAP CER 82pF 50V 10% C0G 0603	KEMET
C51,C52,C93,C94,C95,C96,C113,C116	8	0.1uF	CAP CER 0.1uF 100V 10% X7R AEC-Q200 0805	MURATA

*Table continues on the next page...*

Table 13. BOM list (continued)

Part reference	Quantity	Value	DESCRIPTION	Manufacturer
C53,C103,C109,C110,C111,C112,C114,C117,C119	9	10UF	CAP CER 10UF 50V 10% X7R 1210	MURATA
C62,C63,C64,C74,C75,C76	6	3300PF	CAP CER 3300PF 100V 10% X7R 0805	AVX
C65,C68,C70	3	1000UF	CAP ALEL 1000UF 50V 20% -- AEC-Q200 RADIAL	PANASONIC
C66	1	2200uF	CAP ALEL 2200uF 50V 20% -- AEC-Q200 RADIAL	PANASONIC
C79,C80,C82,C84,C86,C87	6	47PF	CAP CER 47PF 50V 10% C0G 0603	AVX
C102	1	47uF	CAP ALEL 47uF 63V 20% --- AEC-Q200 SMT	PANASONIC
C106	1	0.47uF	CAP CER 0.47uF 16V 10% X7R AEC-Q200 0603	MURATA
C107	1	36PF	CAP CER 36PF 50V 5% C0G 0603	AVX
C115,C118	2	0.68uF	CAP CER 0.68uF 16V 10% X7R AEC-Q200 0805	TDK
D1	1	RED	LED RED CLEAR SGL 20MA 0805	LITE ON
D2,D13	2	HSMG-C170	LED GREEN SGL 2.2V 20MA 0805	AVAGO
D3,D5,D12	3	PMEG10010ELR	DIODE SCH RECT 1A 100V AEC-Q101 SOD123W	NEXPERIA
D4	1	PESD1IVN24-A	DIODE ESD PROTECTION 3.5A 24V 30KV AEC-Q101 SOD323	NEXPERIA
D6	1	BZX384-C30	DIODE ZNR 30V 300mW SOD323	NEXPERIA
D7,D8	2	BAS316	DIODE SW 100V 400mW AEC-Q101 SOD323	NEXPERIA
D9,D10,D11	3	PMEG2005EH	DIODE SCH RECT 500MA 20V SOD123F	NEXPERIA
D15	1	ZENER 15V	DIODE ZNR 0.25A 15V/0.35W SOT-23	FAIRCHILD
D16	1	GF1A	DIODE RECT 1A 50V DO-214BA	VISHAY
J1,J3	2	HDR 1X5	HDR 1X5 TH 100MIL SP 344H AU 118L	WURTH

Table continues on the next page...

Table 13. BOM list (continued)

Part reference	Quantity	Value	DESCRIPTION	Manufacturer
J2	1	HDR 1X4	HDR 1X4 TH 2.54MM SP 344H AU 118L	WURTH
J4	1	HDR 2X5	HDR 2X5 TH 50MIL CTR 167H AU 91L	ANYTRONIC
J5,J6	2	HDR 1X5 RA	HDR 1X5 TH RA FRICTION LOCK 100MIL SP 244H SN 150L	Molex
J7,J10	2	HDR1X2	HDR 1X2 TH 100MIL SP 342H AU 118L	WURTH
J8	1	CON PLUG 4	CON 2X2 PLUG SHRD RA TH 4.2MM CTR 394H AU 138L	Molex
J9	1	CON_1X4	CON 1X4 PLUG SHRD RA TH 4.2MM SP 228H AU	MOLEX
J11	1	CON TB 3	CON 1X3 TB TH 10.16MM SP 1213H SN 197L	Phoenix
J12	1	CON TB 2	CON 1X2 TB TH 10.16MM SP 1213H - 197L	Phoenix
L1	1	120OHM	IND FER BEAD 120 OHM@100MHZ 500MA 25% 0603	MURATA
L2	1	1uH	IND PWR 1uH@100kHz 2.5A 20% SMD	WURTH
L4	1	0.47uH	IND PWR 0.47 uH@100KHZ 47.5A 20% SMT	WURTH
L5	1	100UH	IND PWR 100UH@100KHZ 0.86A 20%SMT	COOPER ELEC
Q2,Q3,Q4,Q5,Q6,Q7,Q8	7	BUK762R4- 60E	TRAN NMOS PWR SW 2.4mOHM 120A 60V AEC-Q101 D2PAK	NEXPERIA
Q9	1	2N7002	TRAN NMOS SW 300mA 60V SOT23	NEXPERIA
RT1	1	10K	THERMISTOR NTC 10K@25DEG 5% AEC-Q200 0603	VISHAY
R1,R2,R3,R4,R5,R6,R7,R65,R6 8,R75,R77,R85,R97,R108,R117, R124,R131,R139	18	120	RES MF 120 OHM 1/10W 1% 0603	YAGEO AMERICA
R8,R9,R11,R12,R13,R17,R18,R 32,R35,R38,R39,R43,R45,R47,R 50,R51,R54,R74,R251	19	0	RES MF ZERO OHM 1/10W -- AEC- Q200 0603	PANASONIC
R10,R33,R36,R42,R241	5	0	RES MF ZERO OHM 1/10W -- AEC- Q200 0603	PANASONIC

Table continues on the next page...

Table 13. BOM list (continued)

Part reference	Quantity	Value	DESCRIPTION	Manufacturer
R14,R247	2	1.0M	RES MF 1.0M 1/10W 1% 0603	WALSIN
R15,R16,R114,R118,R121,R125,R128,R132	8	680	RES MF 680 OHM 1/10W 1% 0603	BOURNS
R19,R20,R21,R22,R23,R24	6	4.7K	RES MF 4.7K 1/10W 5% 0603	VISHAY
R25,R34,R37,R40,R52,R64,R69,R78,R79,R249,R250	11	10.0K	RES MF 10.0K 1/10W 1% 0603	YAGEO AMERICA
R26,R27,R28,R29,R30,R31	6	33	RES MF 33 OHM 1/10W 5% AEC-Q200 0603	VISHAY
R41,R44,R48,R53,R66	5	1.0K	RES MF 1.0K 1/10W 1% 0805	MULTICOMP
R46	1	120	RES MF 120 OHM 1/4W 1% 1206	ROHM
R49,R93,R94,R95,R105,R106,R107	7	100K	RES MF 100K 1/10W 1% 0603	BOURNS
R55,R60,R61,R62	4	10.0K	RES MF 10.0K 1/10W 1% 0603	YAGEO AMERICA
R57,R58,R59	3	4.7	RES MF 4.7 OHM 1/8W 1% 0805	BOURNS
R63,R67,R82,R83,R84,R116,R120,R123,R127,R130,R134,R136,R138,R141	14	24K	RES MF 24.0K 1/10W 1% 0603	VISHAY
R70	1	10K	RES POT 10K 1/2W 10% TH	BOURNS
R71	1	3.0K	RES MF 3.0K 1/10W 1% 0603	WALSIN
R73	1	10K	RES POT 10K 20V 20% TH	ALPS ELECTRIC
R76	1	1.3K	RES MF 1.3K 1/10W 1% AEC-Q200 0603	KOA SPEER
R86,R87,R89,R98,R99,R100	6	2.2 OHM	RES -- 2.2 OHM 1/3W 5% AEC-Q200 1206 ANTISURGE	ROHM
R88,R101,R109,R140	4	2.2K	RES MF 2.2K 1/10W 0.1% 0603	YAGEO AMERICA
R90,R91,R92,R102,R103,R104	6	33	RES MF 33 OHM 1/4W 1% AEC-Q200 0603	VISHAY
R96	1	100K	RES MF 100K 1/4W 5% 1206	ROHM
R110,R111,R112,R113	4	0.001	RES PWR 0.001 OHM 5W 0.2% AEC-Q200 2512	ISABELLENHÈTTE

Table continues on the next page...

Table 13. BOM list (continued)

Part reference	Quantity	Value	DESCRIPTION	Manufacturer
R115,R119,R122,R126,R129,R133	6	470	RES MF 470 OHM 1/10W 1% 0603	VISHAY
R135,R137	2	1K	RES -- 1K 1/4W 1% AEC-Q200 0603 ANTISURGE	ROHM
R239,R240	2	2.0K	RES MF 2.0K 1/10W 5% 0603	BOURNS
R245	1	249K	RES MF 249K 1/10W 1% AEC-Q200 0402	KOA SPEER
R246	1	133K	RES MF 133K 1/10W 1% AEC-Q200 0402	KOA SPEER
R248	1	169K	RES MF 169K 1/10W 1% AEC-Q200 0603	KOA SPEER
SJ1	1	0603_JUMP ER	SOLDER BLOB JUMPER 0603 SHORT NO PART TO ORDER	NO PART TO ORDER
TP1,TP2,TP3,TP10,TP11,TP12, TP13,TP14,TP15,TP16,TP19,TP 27,TP28,TP29,TP30,TP31,TP32, TP33,TP49	19	TPAD_030	TEST POINT PAD 30MIL DIA SMT, NO PART TO ORDER	NOTACOMPONE NT
TP4,TP5,TP6,TP7,TP8,TP9,TP1 7,TP18,TP20,TP21,TP23,TP24,T P36,TP37,TP38,TP39,TP40,TP4 1,TP42,TP43,TP44,TP45,TP46,T P50,TP53	25	TEST POINT WHITE	TEST POINT WHITE 40 MIL DRILL 180 MIL TH 109L	KEYSTONE ELECTRONICS
TP22,TP25,TP26,TP51	4	TEST POINT	TEST POINT PAD 036-018MIL TH, NO PART TO ORDER	NA
TP34,TP47,TP48,TP52	4	TEST POINT BLACK	TEST POINT BLACK 40 MIL DRILL 180 MIL TH 109L	KEYSTONE ELECTRONICS
TP35	1	TEST POINT RED	TEST POINT RED 40 MIL DRILL 180 MIL TH 109L	KEYSTONE ELECTRONICS
U1	1	FS32K142H AT0MLHT	IC MCU 32 BIT 256K MEM 80MHz 2.7-5.5V LQFP64	NXP
U2	1	TJA1021T/2 0/C	IC INTERFACE LIN XCVR 5.5-27V AEC-Q SO8	NXP
U3	1	TJA1043T	IC XCVR CAN HS 4.5-5.5V SO14	NXP

Table continues on the next page...

Table 13. BOM list (continued)

Part reference	Quantity	Value	DESCRIPTION	Manufacturer
U4	1	PESD2IVN2 4-T	DIODE 2 CH ESD PROTECTOR 30KV 24V AEC-Q101 SOT23-3	NEXPERIA
U7,U8,U9,U12	4	BZX84- A5V1	DIODE ZENER 5.1V 250MW AEC- Q101 SOT23	NEXPERIA
U10,U11	2	AD8656	IC LIN AMP DC 28MHZ RAIL-TO-RAIL I/O 2.7-5.5V SOIC8	ANALOG DEVICES
U13	1	MC33GD30 00EP	IC 3PH FET PRE-DRV 8-40V AEC- Q100 QFN56	NXP
U15	1	LM46000AQ PWPRQ1	IC LIN BUCK DCDC SYNC 1-28V 0.5A 3.5-60V HTSSOP16	TEXAS INSTRUMENTS
U16,U17	2	MC33375D	IC VREG LDO 5V 300MA 13V SOIC8	ON
Y1	1	8MHZ	XTAL 8MHZ 8pF AEC-Q200 SMD	NDK



# Chapter 7

## Reference

1. [AN5426 Hardware Design Guidelines for S32K1xx Microcontrollers](#)
2. [S32K1xx MCU Family - Data Sheet](#)
3. [S32K1xx MCU Family - Reference Manual](#)
4. [MC33GD3000, Three Phase Field Effect Transistor Pre-driver - Data Sheet](#)

## How To Reach Us

### Home Page:

[nxp.com](http://nxp.com)

### Web Support:

[nxp.com/support](http://nxp.com/support)

Information in this document is provided solely to enable system and software implementers to use NXP products. There are no express or implied copyright licenses granted hereunder to design or fabricate any integrated circuits based on the information in this document. NXP reserves the right to make changes without further notice to any products herein.

NXP makes no warranty, representation, or guarantee regarding the suitability of its products for any particular purpose, nor does NXP assume any liability arising out of the application or use of any product or circuit, and specifically disclaims any and all liability, including without limitation consequential or incidental damages. "Typical" parameters that may be provided in NXP data sheets and/or specifications can and do vary in different applications, and actual performance may vary over time. All operating parameters, including "typicals," must be validated for each customer application by customer's technical experts. NXP does not convey any license under its patent rights nor the rights of others. NXP sells products pursuant to standard terms and conditions of sale, which can be found at the following address: [nxp.com/SalesTermsandConditions](http://nxp.com/SalesTermsandConditions).

While NXP has implemented advanced security features, all products may be subject to unidentified vulnerabilities. Customers are responsible for the design and operation of their applications and products to reduce the effect of these vulnerabilities on customer's applications and products, and NXP accepts no liability for any vulnerability that is discovered. Customers should implement appropriate design and operating safeguards to minimize the risks associated with their applications and products.

NXP, the NXP logo, NXP SECURE CONNECTIONS FOR A SMARTER WORLD, COOLFLUX, EMBRACE, GREENCHIP, HITAG, I2C BUS, ICODE, JCOP, LIFE VIBES, MIFARE, MIFARE CLASSIC, MIFARE DESFire, MIFARE PLUS, MIFARE FLEX, MANTIS, MIFARE ULTRALIGHT, MIFARE4MOBILE, MIGLO, NTAG, ROADLINK, SMARTLX, SMARTMX, STARPLUG, TOPFET, TRENCHMOS, UCODE, Freescale, the Freescale logo, Altivec, C-5, CodeTEST, CodeWarrior, ColdFire, ColdFire+, C-Ware, the Energy Efficient Solutions logo, Kinetis, Layerscape, MagniV, mobileGT, PEG, PowerQUICC, Processor Expert, QorIQ, QorIQ Qonverge, Ready Play, SafeAssure, the SafeAssure logo, StarCore, Symphony, VortiQa, Vybrid, Airfast, BeeKit, BeeStack, CoreNet, Flexis, MXC, Platform in a Package, QUICC Engine, SMARTMOS, Tower, TurboLink, UMEMS, EdgeScale, EdgeLock, eIQ, and Immersive3D are trademarks of NXP B.V. All other product or service names are the property of their respective owners. AMBA, Arm, Arm7, Arm7TDMI, Arm9, Arm11, Artisan, big.LITTLE, Cordio, CoreLink, CoreSight, Cortex, DesignStart, DynamIQ, Jazelle, Keil, Mali, Mbed, Mbed Enabled, NEON, POP, RealView, SecurCore, Socrates, Thumb, TrustZone, ULINK, ULINK2, ULINK-ME, ULINK-PLUS, ULINKpro, µVision, Versatile are trademarks or registered trademarks of Arm Limited (or its subsidiaries) in the US and/or elsewhere. The related technology may be protected by any or all of patents, copyrights, designs and trade secrets. All rights reserved. Oracle and Java are registered trademarks of Oracle and/or its affiliates. The Power Architecture and Power.org word marks and the Power and Power.org logos and related marks are trademarks and service marks licensed by Power.org.

© NXP B.V. 2019.

All rights reserved.

For more information, please visit: <http://www.nxp.com>

For sales office addresses, please send an email to: [salesaddresses@nxp.com](mailto:salesaddresses@nxp.com)

Date of release: April, 2020

Document Identifier: MCSXTE2BK142HWUG



# Mouser Electronics

Authorized Distributor

Click to View Pricing, Inventory, Delivery & Lifecycle Information:

[NXP:](#)

[MCSXTE2BK142](#)