

温度范围: -25℃~85℃

额定电压: 250V AC/DC

额定电流: 1A

绝缘电阻: ≥1000MΩ

耐压: 800V AC/minute

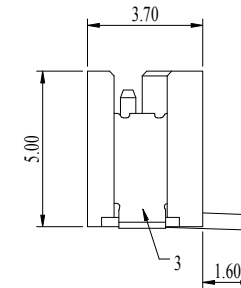
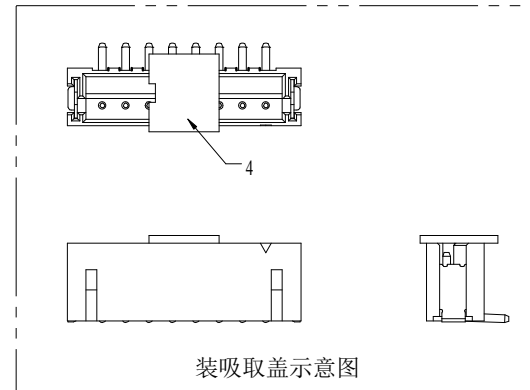
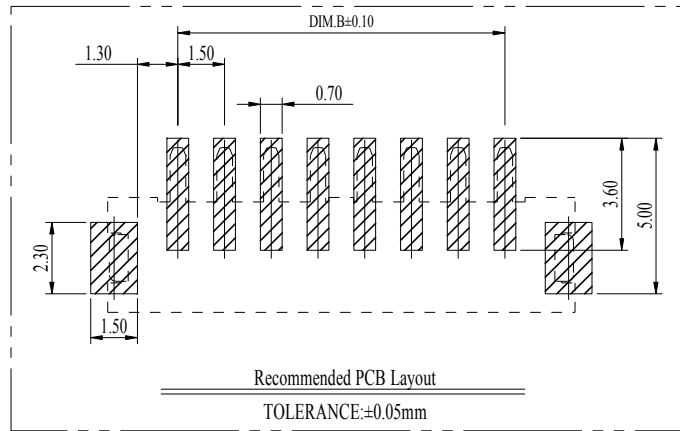
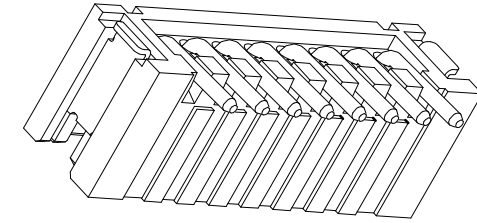
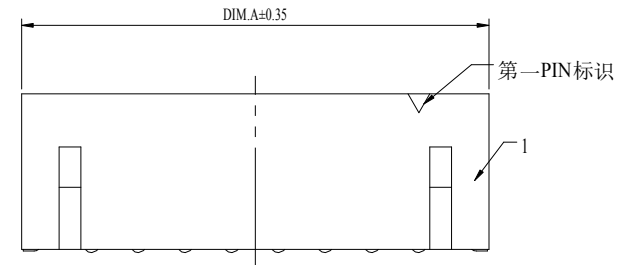
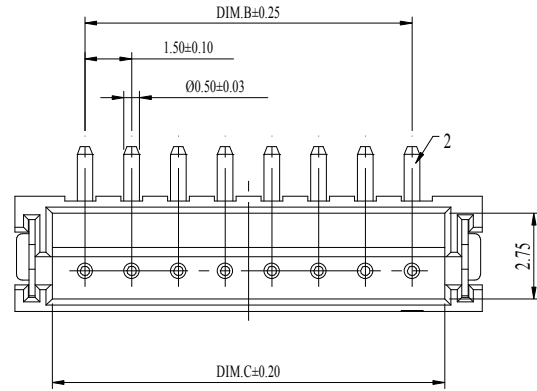

15	25.50	21.00	23.10
14	24.00	19.50	21.60
13	22.50	18.00	20.10
12	21.00	16.50	18.60
11	19.50	15.00	17.10
10	18.00	13.50	15.60
9	16.50	12.00	14.10
8	15.00	10.50	12.60
7	13.50	9.00	11.10
6	12.00	7.50	9.60
5	10.50	6.00	8.10
4	9.00	4.50	6.60
3	7.50	3.00	5.10
2	6.00	1.50	3.60
Pin	DIM.A	DIM.B	DIM.C

1502WVS-XXP	LCP UL94V-0	1502H	1502T
PART NO	Material	Suitable Housing	Suitable Terminal

4	Cap	1 PCS	材质:LCP (UL94V-0), 颜色:本色或黑色
3	FITTING NAIL	2 PCS	材质:磷青铜, 电镀:镀亮锡60u~MIN
2	PIN	n PCS	材质:黄铜, 电镀:镀亮锡60u~MIN
1	Housing	1 PCS	材质:LCP (UL94V-0), 颜色:本色或黑色
NO.	NAME	Q'TY	DESCRIPTION

new		2015/5/3		A		瀚源	
ECN BO.		DESCRIPTION.		DATE.		REV.	
DESIGNED	CHECKED	APPROVAL	DRAWING NUMBER	SCALT: 1/2		SCALE: 3:1	
Mikey	Tom	Jerry	PART NAME	1502WVS-XXP	UNLESS OTHERWISE SPECIFIED,TOLERANCE:	X.	±0.25
			MODEL NAME	H-1502WVS-XXP		X.x	±0.20
			3RD ANGLE PROJ	HanElectricity Co.,LTD			X.xx
			FILE.NO.				