

Wide-input Voltage 40V, 4A, 200kHz Step-Down DC/DC Converter

FEATURES

- High Efficiency: Up to 95% @ 5V
- Quiescent Current $I_q=1\text{mA}$ (typ.)
- Wide input voltage: 5V ~ 40V
- 45V Input Voltage Surge
- Up to 5A Output Current @ $V_{IN}=12\text{V}$
- Up to 4A Output Current @ $V_{IN}=24\text{V}$
- Output Voltage up to 12V
- 200kHz Switching Frequency
- Compensation of Input /Output Voltage Change
- Independent of inductance and Inductor DCR
- $\pm 2\%$ Feedback Voltage Accuracy
- Integrated Soft Start
- Thermal Shutdown
- Secondary Cycle-by-Cycle Current Limit
- EMI Consideration
- ESOP8 Package

GENERAL DESCRIPTION

TMI3494 is a wide input voltage, high efficiency Active CC, non-synchronous step-down DC/DC converter that operates in either CV (Constant Output Voltage) mode or CC (Constant Output Current) mode. TMI3494 provides up to 5A output current at $V_{IN}=12\text{V}$ with 200kHz switching frequency, the device integrates 40mΩ Power MOS, and has advanced features include UVLO, Thermal Shutdown, Soft Start, OVP.

APPLICATIONS

- Automotive Equipment
- Car Charger/ Adaptor
- Rechargeable Portable Devices
- General-Purpose DC/DC Supply

TYPICAL APPLICATION

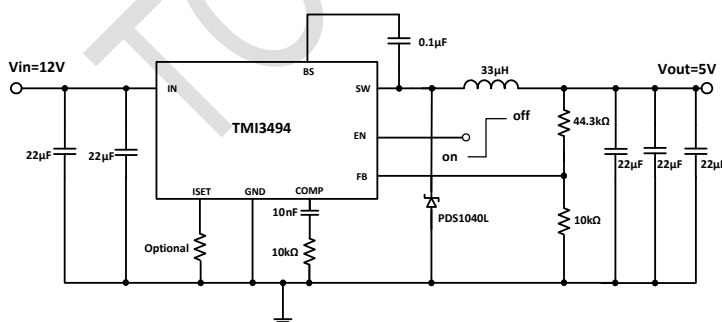
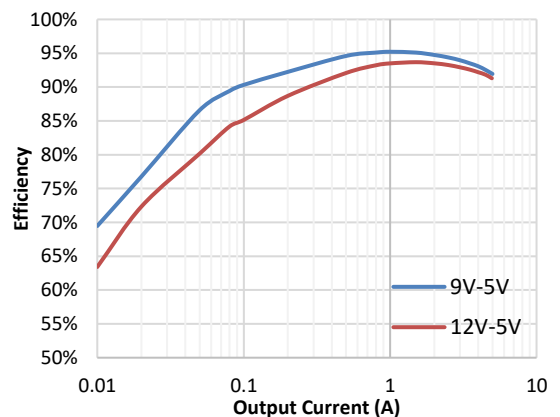

Figure 1. Basic Application Circuit

Efficiency

$V_{OUT}=5\text{V}$, $I_{OUT}=0.01\text{A}$ to 5A, $T_A=25^\circ\text{C}$



ABSOLUTE MAXIMUM RATINGS (Note 1)

Parameter	Value	Unit
Input Supply Voltage, SW	-0.3~45	V
BS to SW Voltage	-0.3~6.0	V
All Pins Voltage	-0.3~6.0	V
Storage Temperature Range	-50~150	°C
Junction Temperature (Note2)	-40~150	°C

PACKAGE/ORDER INFORMATION

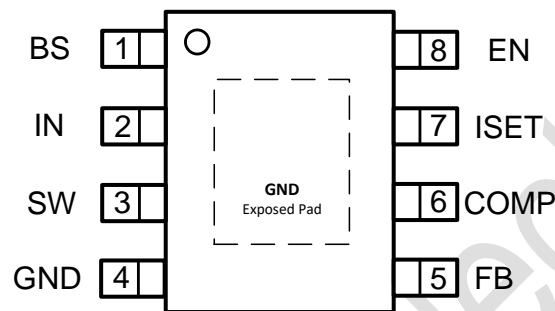

ESOP8

Top Mark: T3494/YYXXX (T3494: Device Code, YYXXX: Inside Code)

Part Number	Package	Top mark	Quantity/ Reel
TMI3494	ESOP8	T3494/YYXXX	3000

TMI3494 devices are Pb-free and RoHS compliant.

PIN FUNCTIONS

Pin	Name	Function
1	BS	High-side gate driver bootstrap pin. Provide supply to high-side LDMOS gate driver. Connect a 0.1 μ F capacitor between BS and SW
2	IN	Power input pin.
3	SW	Switch Pin. Connect to external Inductor
4	GND	Ground pin
5	FB	Feedback pin
6	COMP	External compensation pin
7	ISSET	Limit current set pin
8	EN	Active low enable pin. Drive EN logic Low to enable the regulator; Drive EN logic high to turn off the regulator. Don't leave EN pin floating.
9	GND	Ground (Exposed pad)

ESD RATING

Items	Description	Value	Unit
V _{ESD}	Human Body Model for all pins	\pm 2000	V

JEDEC specification JS-001
RECOMMENDED OPERATING CONDITIONS

Items	Description	Min	Max	Unit
Voltage Range	V _{IN}	5	40	V

THERMAL RESISTANCE (Note 3)

Items	Description	Value	Unit
θ_{JA}	Junction-to-ambient thermal resistance	60	$^{\circ}$ C/W

ELECTRICAL CHARACTERISTICS

($V_{IN}=12V$, $V_{OUT}=5V$, $T_A = 25^{\circ}C$, unless otherwise noted.)

Parameter	Symbol	Conditions	Min	Typ	Max	Unit
Input Voltage Range	V_{IN}		5		40	V
Under Voltage Lockout	V_{UVLO}	V_{IN} rising		4.4		V
UVLO Hysteresis	V_{UVLO_HY}			0.3		V
Input Supply Current	I_{IN}	No load, $V_{FB}=1.1V$		1	1.5	mA
Shutdown Current	I_{SD}	$EN = 3.3V$		15		μA
Feedback Threshold Voltage	V_{FBTH}	PWM operation	902	920	938	mV
FB Pin input current	I_{FB}		-50		50	nA
EN Enable Low Input Voltage	V_{ENTH}				0.4	V
EN Shutdown High Input Voltage	V_{ENSD}		1.4			V
Input OVP Threshold Voltage	V_{INOVF}			41		V
Soft start Time	T_{SST}			4.6		ms
Current limit cycle-by-cycle	I_{LIM_MAX}	$V_{IN}=12V$, ISET pin floating		6		A
		$V_{IN}=24V$, ISET pin floating		4.2		A
SW leakage	I_{SW_LEAK}				10	μA
ISET Pull Up Current	V_{ISET}			10		μA
Switch On-Resistance (high side)	R_{DSONH}			40		m Ω
Oscillator Frequency	F_{OSC}			200		kHz
Short circuit Frequency	F_{SC}	$V_{FB}=0V$		40		kHz
Minimum Turn-on Time	T_{ON_MIN}			200		ns
Maximum Duty-cycle	D_{MAX}	$V_{FB}=0.8V$		90		%
Thermal Shutdown Threshold (Note 3)	T_{SDN}			150		$^{\circ}C$
Thermal Shutdown Hysteresis (Note 3)	T_{SDN_HY}			20		$^{\circ}C$

Note 1: Absolute Maximum Ratings are those values beyond which the life of a device may be impaired.

Note 2: T_J is calculated from the ambient temperature T_A and power dissipation P_D according to the following formula: $T_J = T_A + (P_D) \times \theta_{JA}$.

Note 4: Thermal shutdown threshold and hysteresis are guaranteed by design.

FUNCTIONAL BLOCK DIAGRAM

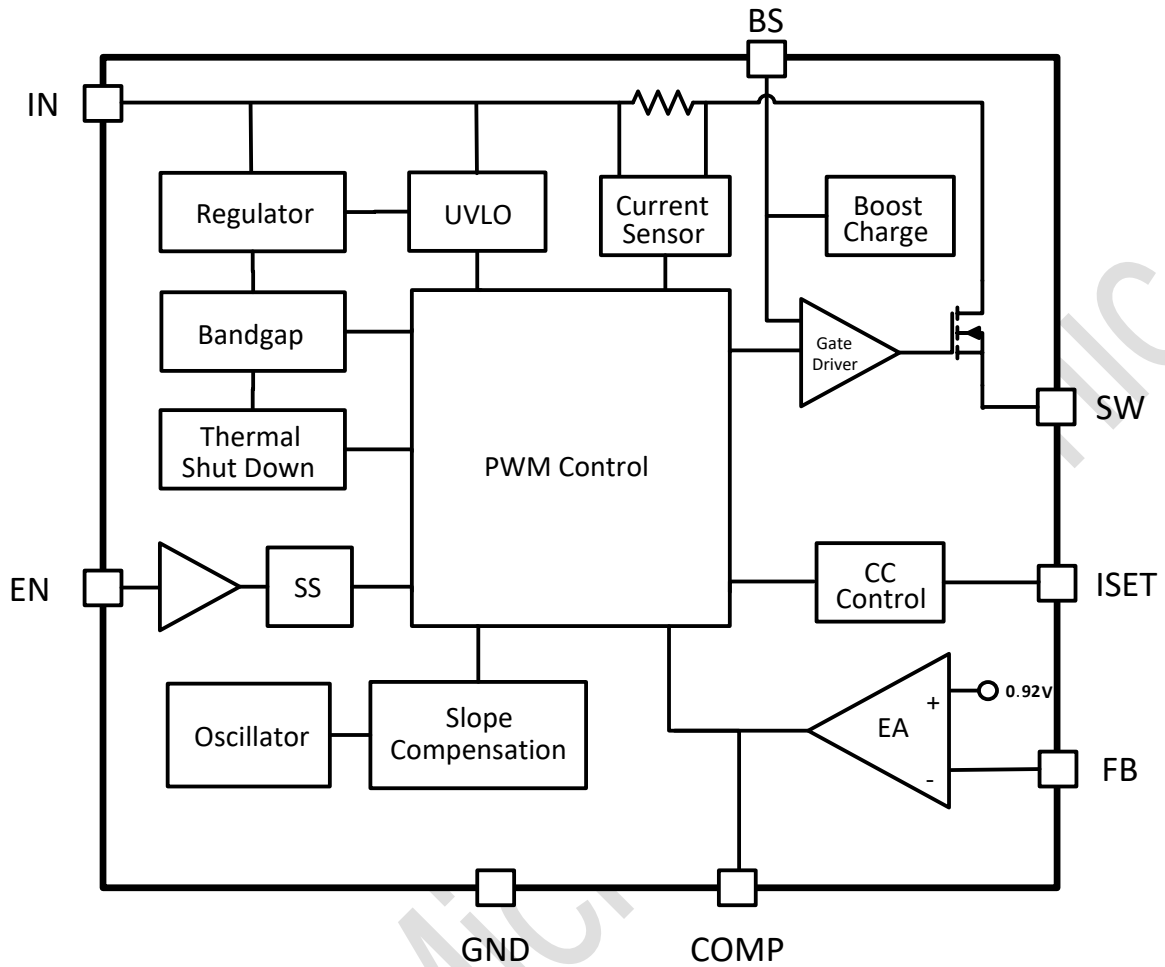

Figure 2. TMI3494 Block Diagram

FUNCTION DESCRIPTION

CV/CC Loop Regulation

As seen in functional block diagram, the TMI3494 is a peak current mode pulse width modulation (PWM) converter with CC and CV control. The converter operates as follows:

A switching cycle starts when the rising edge of the oscillator clock output causes the high-side power switch to turn on and the low-side power switch to turn off. With the SW side of the inductor now connected to in, the inductor current ramps up to store energy in the magnetic field. The inductor current level is measured by the current sense amplifier and added to the oscillator ramp signal. If the resulting summation is higher than the comp voltage, the output of the PWM comparator goes high. When this happens or when oscillator clock output goes low, the high-side power switch turns off.

At this point, the SW side of the inductor swings to a diode voltage below ground, causing the inductor current to decrease and magnetic energy to be transferred to output. This state continues until the cycle starts again. The high-side power switch is driven by logic using BS as the positive rail. This pin is charged to $V_{SW} + 5V$ when the low-side power switch turns on. The COMP voltage is the integration of the error between fb input and the internal 0.92V reference. If FB is lower than the reference voltage, COMP tends to go higher to increase current to the output. Output current will increase until it reaches the CC limit set by the ISET resistor. At this point, the device will transition from regulating output voltage to regulating output current, and the output voltage will drop with increasing load.

The oscillator normally switches at 200kHz. However, if FB voltage is less than 0.5V, then the switching frequency decreases until it reaches a typical value of 40kHz at $V_{FB} = 0.15V$.

Over Voltage Protection

The thresholds of input OVP circuit include are typical 41V. Once the input voltage is higher than the threshold, the high-side MOSFET is turned off. When the input voltage drops lower than the threshold, the high-side MOSFET will be enabled again.

Thermal Shutdown

The TMI3494 disables switching when its junction temperature exceeds 155°C and resumes when the temperature has dropped by 20°C.

Output Voltage Setting

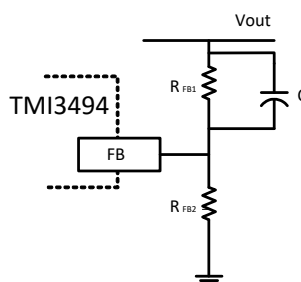

Figure 3. Output Voltage Setting

Figure 3 shows the connections for setting the output voltage. Select the proper ratio of the two feedback resistors R_{FB1} and R_{FB2} based on the output voltage. Adding a capacitor in parallel with R_{FB1} helps the system stability. Typically, use $R_{FB2} \approx 10k\Omega$ and determine R_{FB1} from the following equation:

$$R_{FB1} = R_{FB2} \left(\frac{V_{OUT}}{0.92V} - 1 \right)$$

CC Current Setting

TMI3494 constant current value is set by a resistor connected between the ISET pin and GND. The output current threshold is proportional to the ISET pin voltage. To determine the proper resistor value for a desired output current threshold, please refer to Figure 4 below.

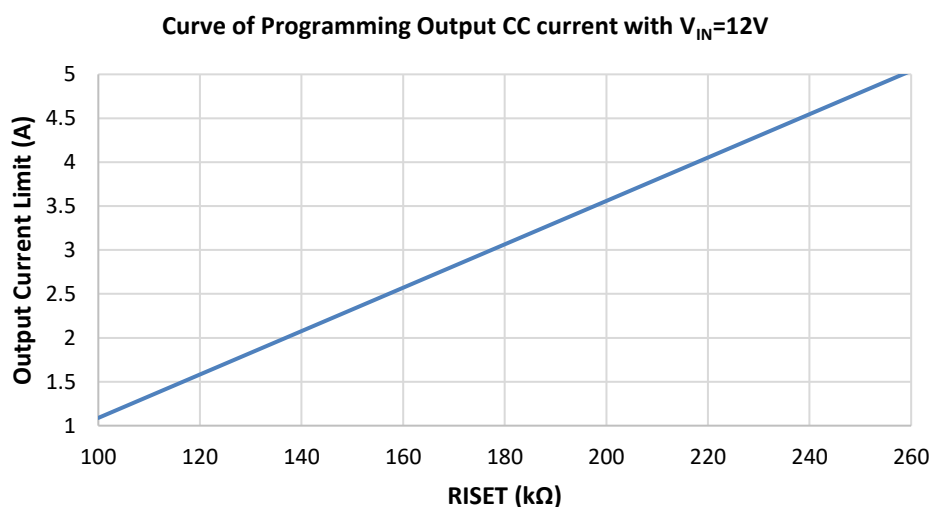

Figure 4. Curve of Programming Output CC Current

CC Loop Stability

The constant-current control loop is internally compensated over the 1.5A - 5A output range. No additional external compensation is required to stabilize the CC current.

EMI Consideration

Since parasitic inductance and capacitance effects in PCB circuitry would cause a spike voltage on SW node when high-side MOSFET is turned on/off, this spike voltage on SW may impact on EMI performance in the system. In order to enhance EMI performance, there are two methods to suppress the spike voltage. One is to place an RC snubber between SW and GND and make them as close as possible to the high-side MOSFET's source and low-side MOSFET's drain. Another method is to add a resistor in series with the bootstrap capacitor. But this method will decrease the driving capability to the high-side MOSFET. It is strongly recommended to reserve the RC snubber during PCB layout for EMI improvement. Moreover, reducing the SW trace area and keeping the main power in a small loop will be helpful on EMI performance.

PC Board Layout Guidance

When laying out the printed circuit board, the following checklist should be used to ensure proper operation of the IC.

- 1) Arrange the power components to reduce the AC loop size consisting of C_{IN} , IN pin, SW pin and the schottky diode.
- 2) Place input decoupling ceramic capacitor C_{IN} as close to IN pin as possible. C_{IN} is connected power GND with vias or short and wide path.
- 3) Return FB, COMP and ISET to signal GND pin, and connect the signal GND to power GND at a single point for best noise immunity. Connect exposed pad to power ground copper area with copper and vias.
- 4) Use copper plane for power GND for best heat dissipation and noise immunity.
- 5) Place feedback resistor close to FB pin.
- 6) Use short trace connecting BS- C_{BS} -SW loop
- 7) Place Schottky diode as close to GND pin as possible.

TYPICAL PERFORMANCE CHARACTERISTICS

($V_{IN}=12V$, $V_{OUT}=5V$, $C_{IN}=22\mu F \times 2$, $C_{OUT}=22\mu F \times 3$, $L1=33\mu H$, $T_A=25^\circ C$, unless otherwise noted.)

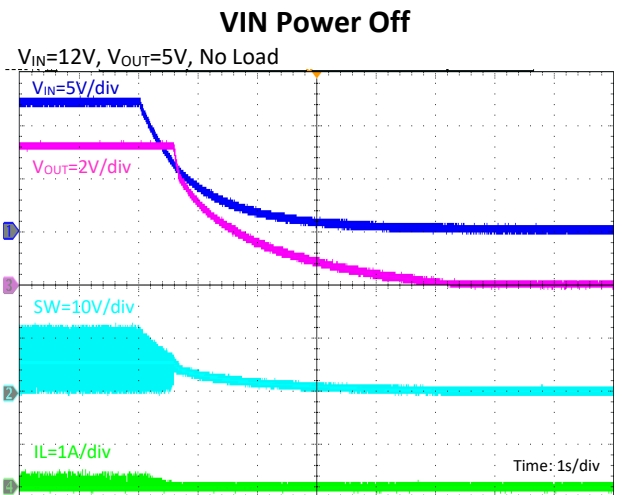
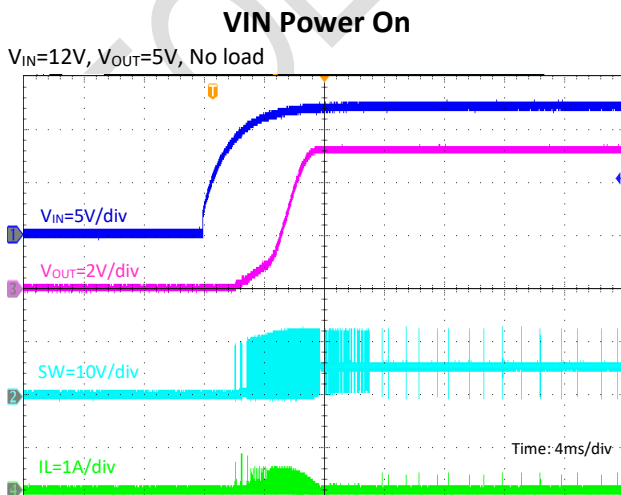
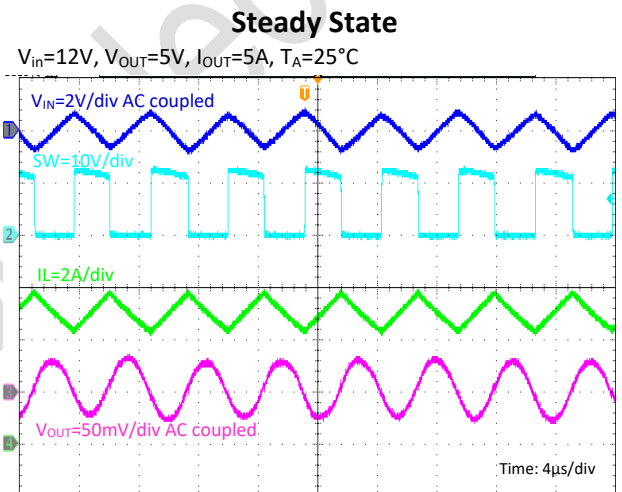
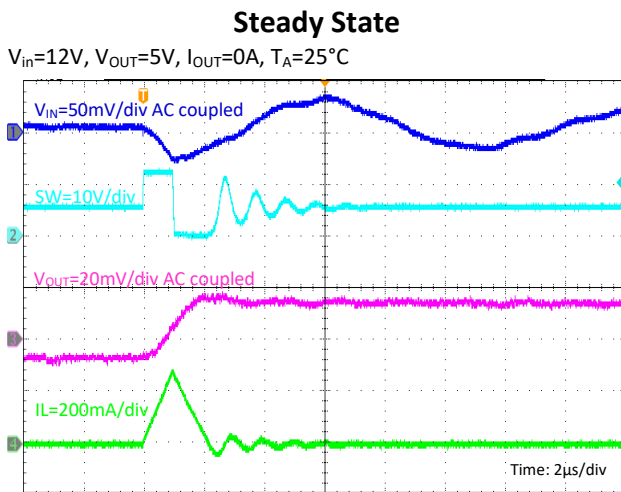
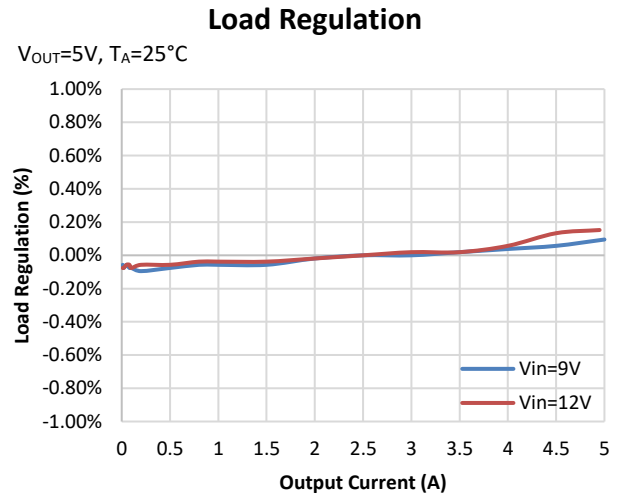
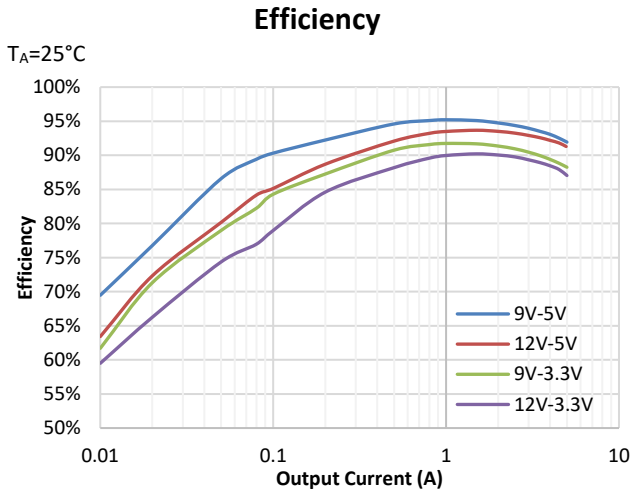

TYPICAL PERFORMANCE CHARACTERISTICS (Continued)

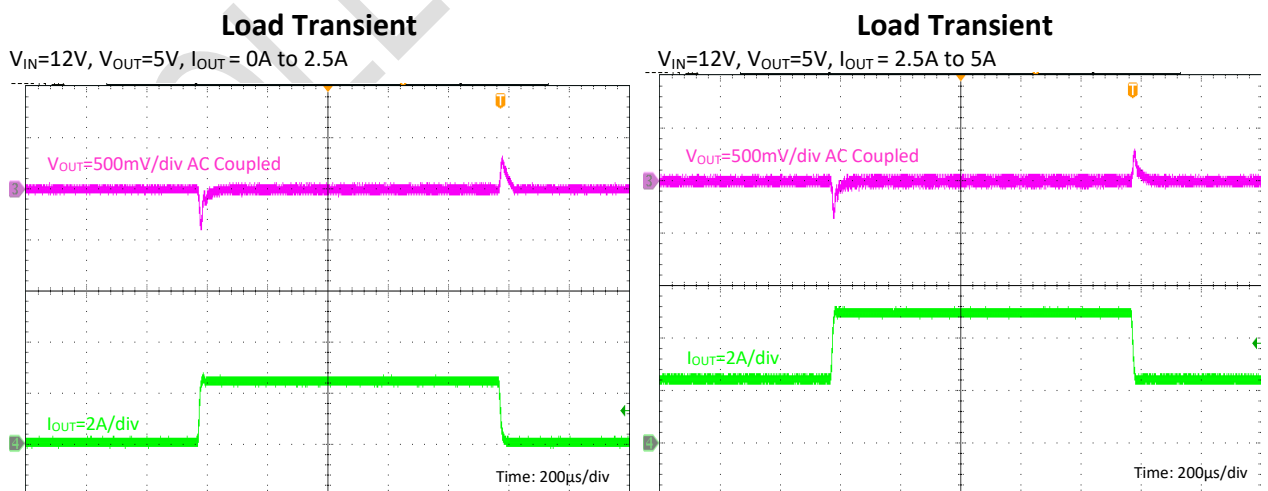
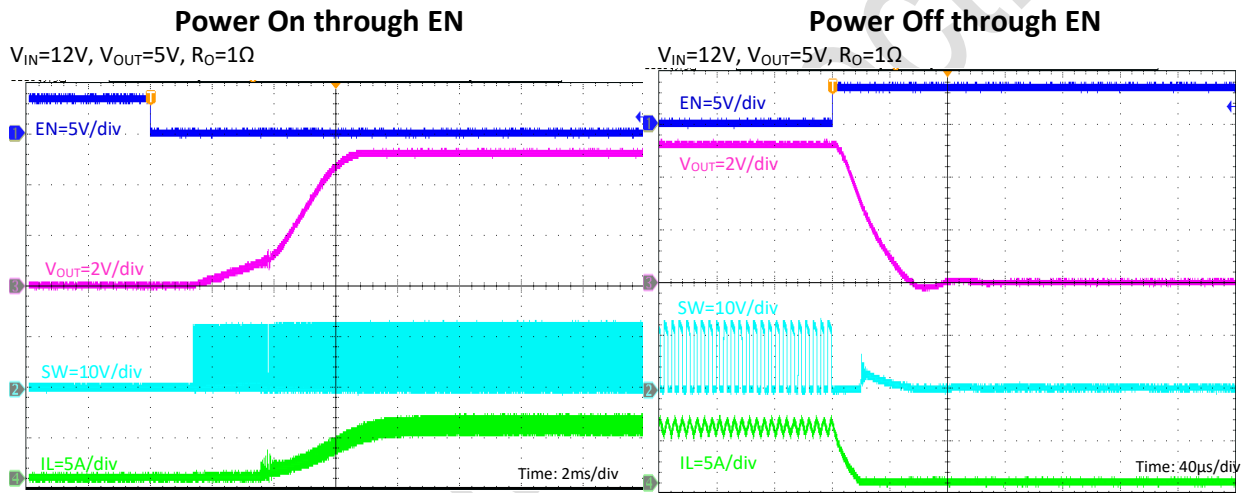
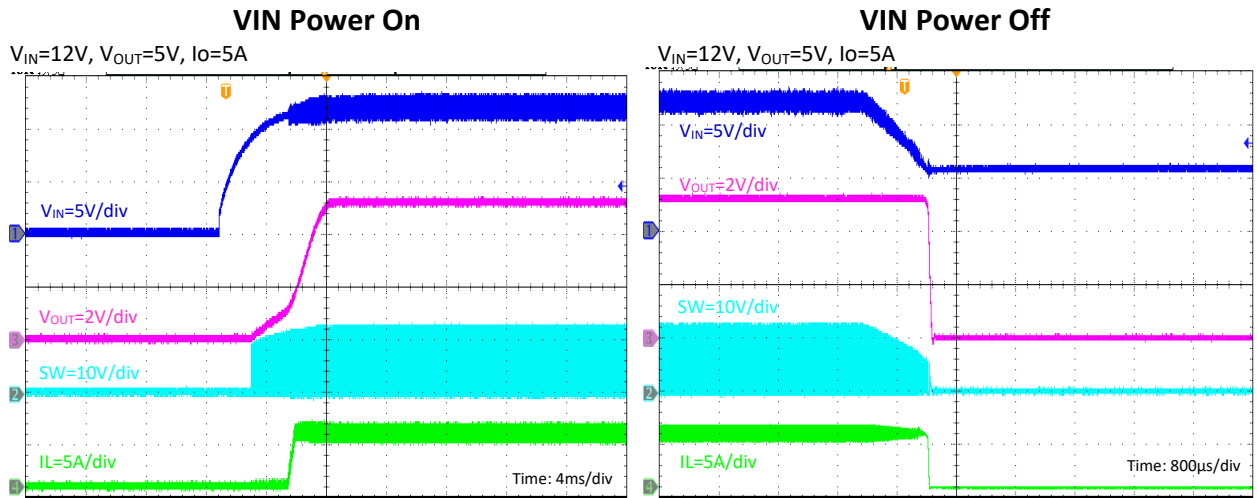

PACKAGE INFORMATION

ESOP8

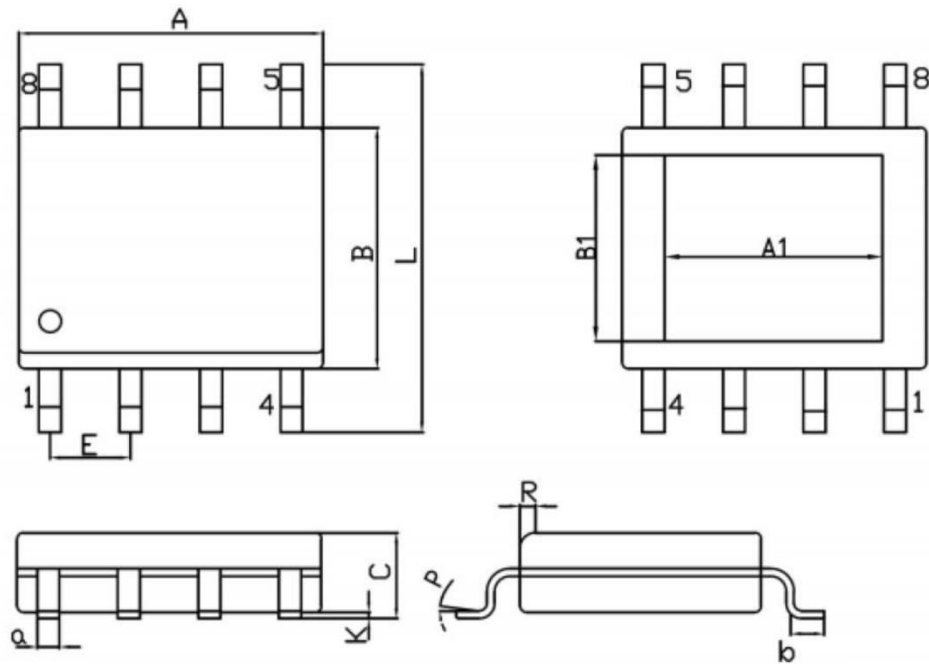

Unit: mm

Symbol	Dimensions In Millimeters		Symbol	Dimensions In Millimeters	
	Min	Max		Min	Max
A	4.70	5.10	C	1.35	1.75
B	3.70	4.10	a	0.35	0.49
L	6.00	6.40	R	0.30	0.60
E	1.27 BSC		P	0°	7°
K	0.02	0.10	b	0.40	1.25
A1	3.1	3.5	B1	2.2	2.6

Note:

- 1) All dimensions are in millimeters.
- 2) Package length does not include mold flash, protrusion or gate burr.
- 3) Package width does not include inter lead flash or protrusion.
- 4) Lead popularity (bottom of leads after forming) shall be 0.10 millimeters max.
- 5) Pin 1 is lower left pin when reading top mark from left to right.

TAPE AND REEL INFORMATION

TAPE DIMENSIONS:

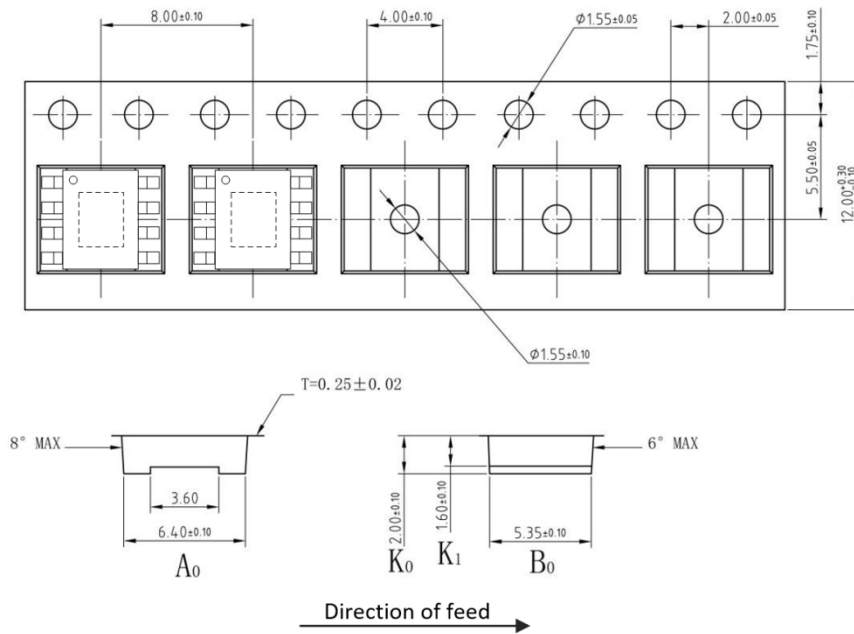

REEL DIMENSIONS:

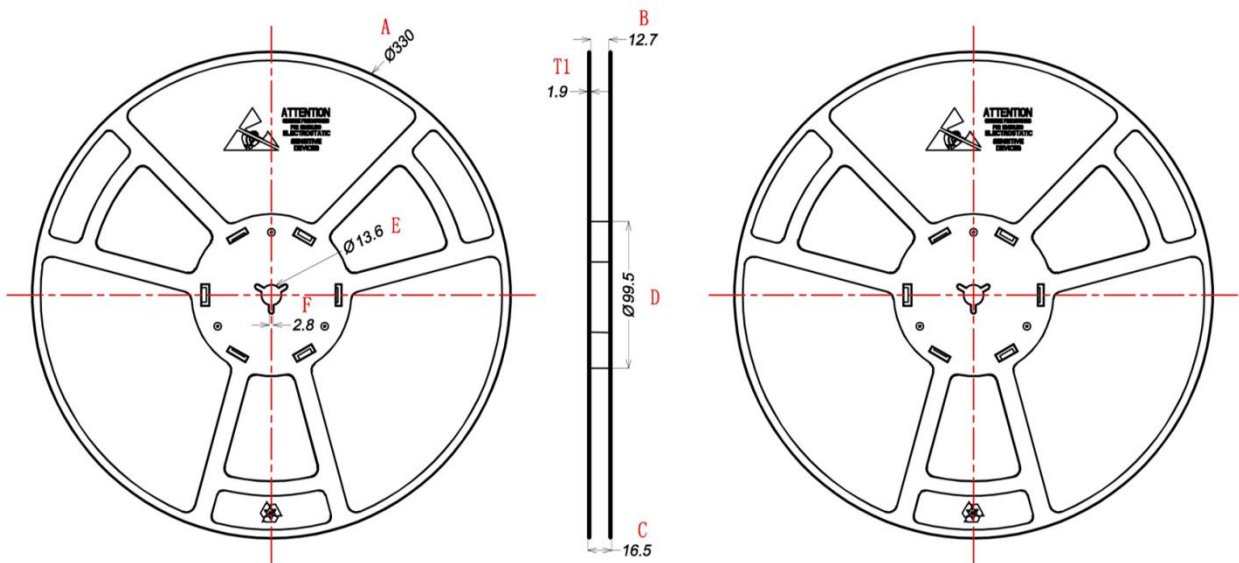

Unit: mm

A	B	C	D	E	F	T1
$\phi 330 \pm 1$	12.7 ± 0.5	16.5 ± 0.3	$\phi 99.5 \pm 0.5$	$\phi 13.6 \pm 0.2$	2.8 ± 0.2	1.9 ± 0.2

Note:

- 1) All Dimensions are in Millimeter
- 2) Quantity of Units per Reel is 3000
- 3) MSL level is level 3.