

HBRA10200BCT & HBRA10200HCT

10.0AMPS. SCHOTTKY BARRIER RECTIFIERS

FEATURE

- . High current capability
- . Low forward voltage drop
- . Low power loss, high efficiency
- . High surge capability
- . High temperature soldering guaranteed
260°C /10seconds, 0.25"(6.35mm)from case.

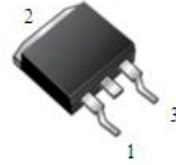

TO-262
HBRA10200BCT



TO-262
HBRA10200HCT

MECHANICAL DATA

- . Case: Molded with UL-94 Class V-0 recognized
Flame Retardant Epoxy
- . Mounting position: any

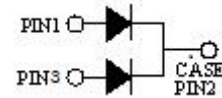

Single phase, half wave, 60Hz, resistive or inductive load.

For capacitive load, derate current by 20%

MAXIMUM RATINGS (T_C=25°C unless otherwise noted)

Parameter	Symbol	HBRA10200BCT & HBRA10200HCT	Units
Maximum Recurrent Peak Reverse Voltage	V_{RRM}	200	V
Maximum RMS Voltage	V_{RMS}	140	V
Maximum DC blocking Voltage	V_{DC}	200	V
Maximum Average Forward Rectified Current <i>Per Leg</i> at T _C =100°C <i>Total device</i>	$I_{F(AV)}$	5.0 10.0	A
Peak Forward Surge Current 8.3ms single half sine-wave superimposed on rated load (JEDEC method) <i>Per Leg</i>	I_{FSM}	120.0	A
Typical Junction Capacitance (Note 1)	C_J	60	pF
Operation Junction Temperature and Storage Temperature	T_J, T_{STG}	-55 to +175	°C

ELECTRICAL CHARACTERISTICS - (Per Leg) (T_C=25°C unless otherwise noted)

Parameter	Symbol	Test conditions	Typ	Max	Units	
Forward voltage drop	V_F	T _J =25°C	I _F =2A	0.76	----	V
			I _F =5A	0.83	0.90	
		T _J =125°C	I _F =2A	0.61	----	
			I _F =5A	0.69	0.80	
Reverse leakage current	I_R	T _J =25°C	V _R =200V	----	20	uA
		T _J =125°C	V _R =200V	----	5	mA

THERMAL CHARACTERISTICS (T_C=25°C unless otherwise noted)

Parameter	Symbol	HBRA10200BCT	HBRA10200HCT	Units
Typical Thermal Resistance (Note 2)	$R_{(JC)}$	2.0	2.0	°C/W

Notes:

1. Measured at 1.0 MHz and applied reverse voltage of 4.0Vdc
2. Thermal Resistance from Junction to Case

RATING AND CHARACTERISTIC CURVES

FIG1-TYPICAL FORWARD CURRENT DERATING CURVE

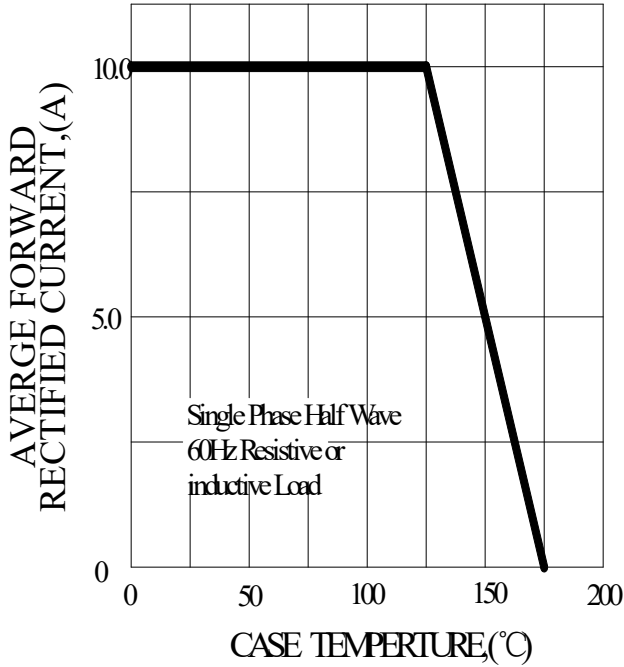

FIG2-TYPICAL INSTANTANEOUS FORWARD CHARACTERISTICS

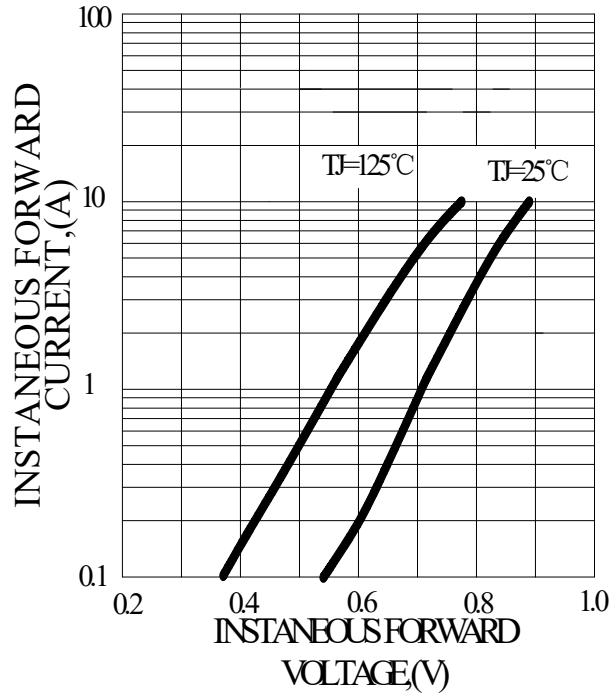

FIG3-MAXIMUM NON-REPETITIVE FORWARD SURGE CURRENT

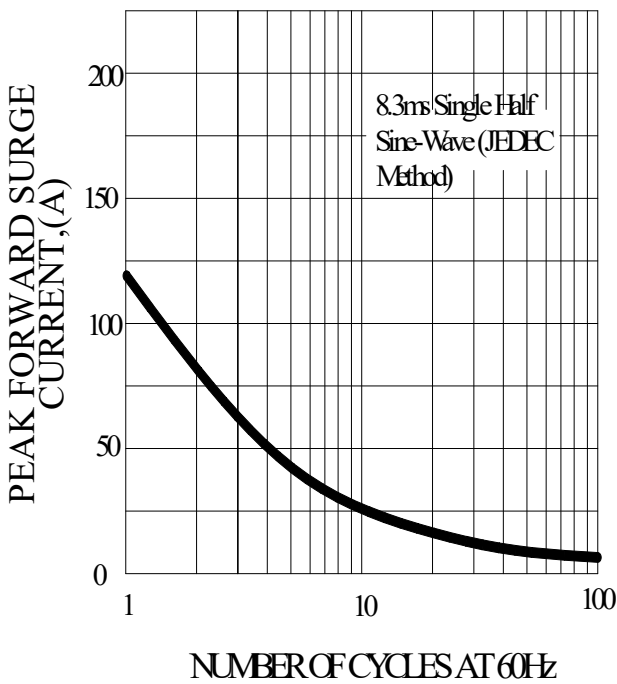
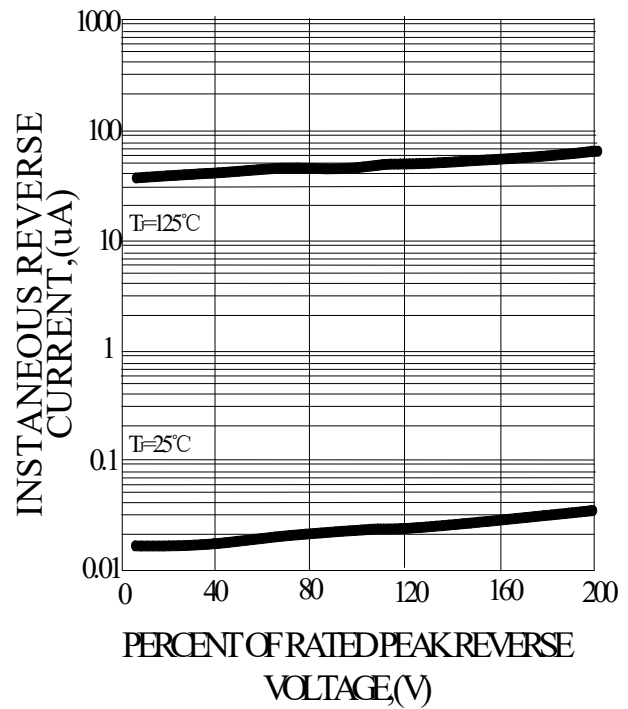
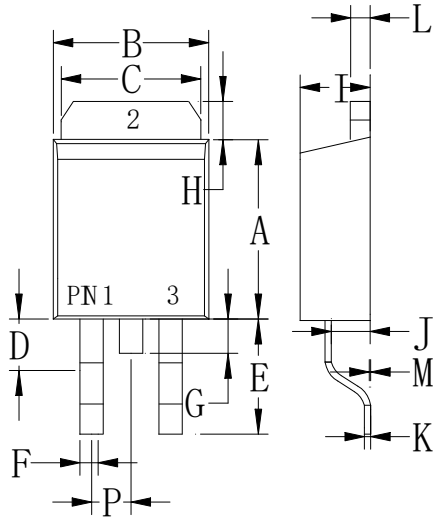

FIG4-TYPICAL REVERSE CHARACTERISTICS



PACKAGE OUTLINE DIMENSIONS

TO-263



TO-263		
Dim	Min	Max
A	.323 (8.20)	.348 (8.85)
B	.394 (10.0)	.413 (10.5)
C	.394 (10.0)	.402 (10.2)
D	.077 (1.95)	.100 (2.55)
E	.204 (5.17)	.227 (5.77)
F	.027 (0.68)	.037 (0.94)
G	—	.067 (1.70)
H	.046 (1.17)	.053 (1.34)
I	.175 (4.44)	.191 (4.86)
J	.100 (2.54)	.110 (2.79)
K	.014 (0.35)	.025 (0.64)
L	.047 (1.20)	.055 (1.40)
M	.000 (0.00)	.010 (0.25)
P	.095 (2.41)	.105 (2.67)

Dimensions in inches and (millimeters)

TO-262

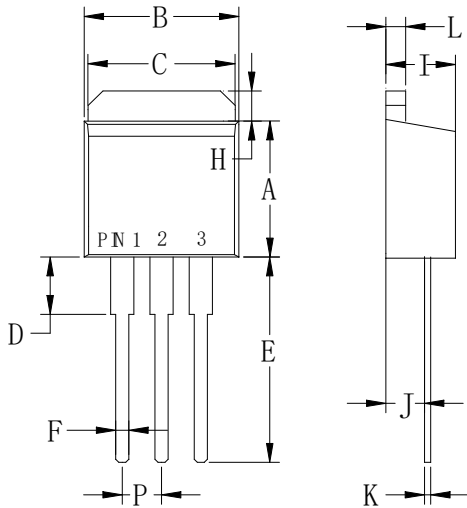

TO-262		
Dim	Min	Max
A	.323 (8.20)	.348 (8.85)
B	.394 (10.0)	.413 (10.5)
C	.394 (10.0)	.402 (10.2)
D	.140 (3.56)	.160 (4.06)
E	.510 (13.0)	.560 (14.3)
F	.027 (0.68)	.037 (0.94)
H	.046 (1.17)	.053 (1.34)
I	.175 (4.44)	.185 (4.86)
J	.100 (2.54)	.110 (2.79)
K	.014 (0.35)	.025 (0.64)
L	.045 (1.14)	.055 (1.40)
P	.095 (2.41)	.105 (2.67)

Dimensions in inches and (millimeters)

Marking and packaging illustration

1、Marking

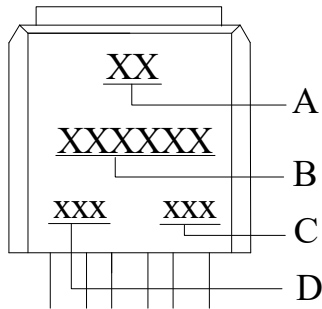

SYMBOL	Explanation
A	Trademark
B	Product Name
C	Date Code
D	Product Information

2、Packaging

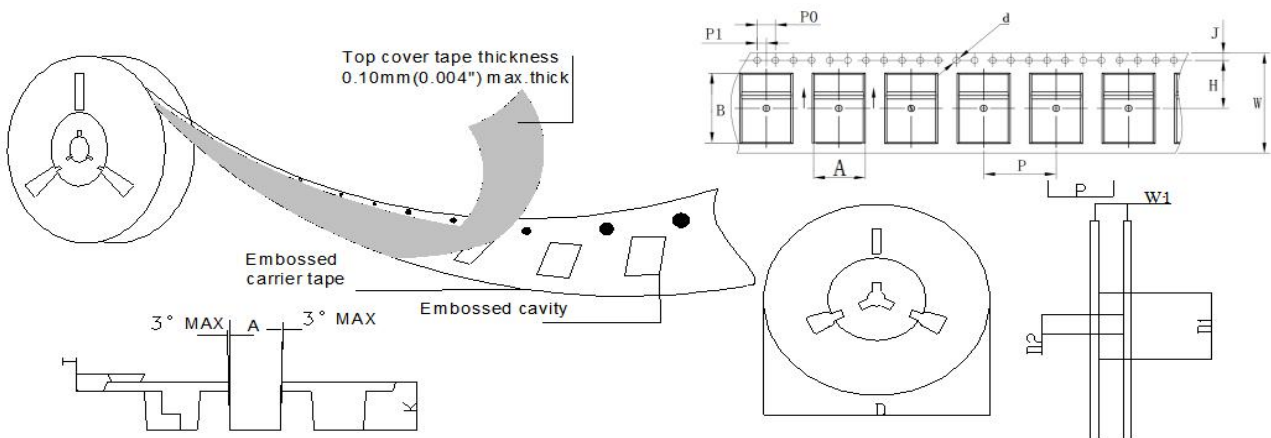

SPECIFICATIONS mm(inch)		PACKAGE	SPECIFICATIONS mm(inch)		PACKAGE
ITEM	SYM BOL	TO-263	ITEM	SYM BOL	TO-263
Carrier width	A	11.65(0.459)Max	Carrier depth	K	5.15(0.203)Typ
Carrier length	B	17.05(0.672)Max	Punch hole pitch	P	16.00(0.630)Typ
Sprocket hole	d	ø1.50(0.059)Typ	Sprocket hole pitch	P0	4.00(0.157)Typ
Reel outer diameter	D	330.0(13.0)Typ	Embossment center	P1	2.00(0.079)Typ
Reel inner diameter	D1	90.0(3.54)Min	Overall tape thickness	T	0.40(0.016)Typ
Feed hole diameter	D2	13.0(0.512)Typ	Tape width	W	24.0(0.945)Typ
Sprocket hole position	J	1.75(0.069)Typ	Reel width	W1	25.5(1.000)Min
Punch hole position	H	11.50(0.453)Typ			

2.1 真空包装:



铝箔袋



湿度卡



干燥剂

2.2 产品内盒及尺寸：（1600pcs / Box）

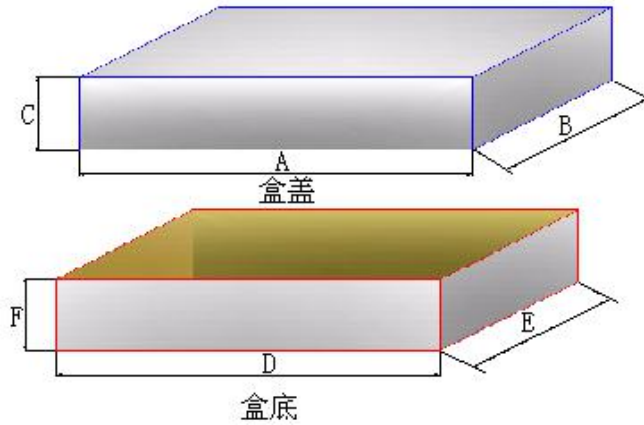

类别	A	B	C	D	E	F
TO-263	338	338	63	334	334	61

- 说明：1)、料为瓦楞纸,厚度 1.5mm。
 2)、标示尺寸为内部尺，公差为+1/- 2mm。
 3)、上下表面要求光滑,不得有污染，有划痕等不良。
 4)、盒底和盒盖组合后，要求方正平直。

2.3 产品外箱及尺寸：（8000pcs / Carton）

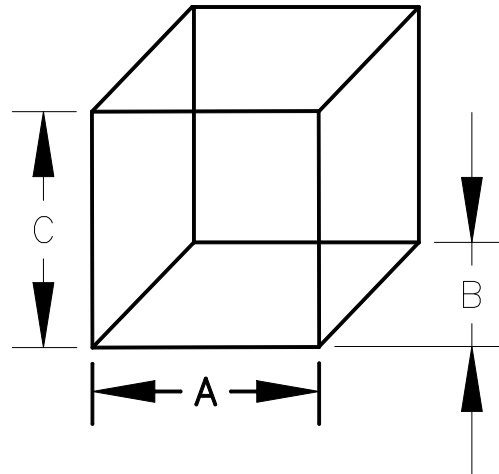

产品名称	包装外形	A	B	C
TO-263	装 5 个卷装内盒	350	350	345

- 说明：1)、材质：5层瓦楞纸。
 2)、颜色：牛皮纸原色。
 3)、厚度：5.5mm(min)。
 4)、公差：±3mm。
 5)、尺寸标注：内部尺寸。