



TAI-SAW TECHNOLOGY CO., LTD.

No. 3, Industrial 2nd Rd., Ping-Chen Industrial District,
Taoyuan, 324, Taiwan, R.O.C.

TEL: 886-3-4690038 FAX: 886-3-4697532

E-mail: tstsales@mail.taisaw.com Web: www.taisaw.com

Product Specifications Approval Sheet

Product Description: SAW Filter 918.6 MHz SMD 3.8x3.8 mm (BW=3.6 MHz)

TST Part No.: TA1449A

Customer Part No.: _____

Customer signature required
Company: _____
Division: _____
Approved by : _____
Date: _____

Checked by: _____ David Chang 張閱智

Approved by: _____ Francis Chen 

Date: _____ 2012/01/04

1. Customer signed back is required before TST can proceed with sample build and receive orders.
2. Orders received without customer signed back will be regarded as agreement on the specifications.
3. Any specifications changes must be approved upon by both parties and a new revision of specifications shall be released to reflect the changes.



TAI-SAW TECHNOLOGY CO., LTD.

No. 3, Industrial 2nd Rd., Ping-Chen Industrial District,
Taoyuan, 324, Taiwan, R.O.C.

TEL: 886-3-4690038 FAX: 886-3-4697532

E-mail: tstsales@mail.taisaw.com Web: www.taisaw.com

SAW Filter 918.6 MHz

MODEL NO.:TA1449A

REV. NO.:1

A. MAXIMUM RATING:

1. Input Power Level: 10 dBm
2. DC Voltage : 5 V
3. Operating Temperature: 0°C to +80°C
4. Storage Temperature: -30°C to +85°C

RoHS Compliant
Lead free
Lead-free soldering

Electrostatic Sensitive Device (ESD)

B. ELECTRICAL CHARACTERISTICS:

Item	Unit	Min.	Typ.	Max.
Center frequency F_c	MHz	-	918.6	-
Insertion Loss (916.8~920.4 MHz) IL	dB	-	3.5	7
Amplitude Ripple (916.8~920.4 MHz)	dB	-	1.0	4.5
Attenuation (Reference level from 0 dB)				
715 ~ 900 MHz	dB	15	50	-
900 ~ 915 MHz	dB	2.5	4	-
928 ~ 1000 MHz	dB	5	26	-
1000 ~ 1500 MHz	dB	15	40	-
Temperature Coefficient of Frequency	ppm/°C	-	-36	-

C. MEASUREMENT CIRCUIT:

HP Network analyzer

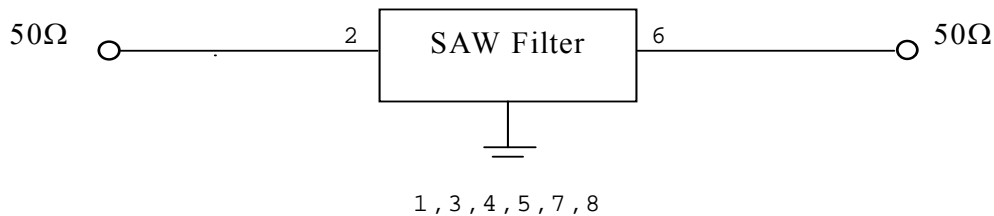

D. OUTLINE DRAWING:

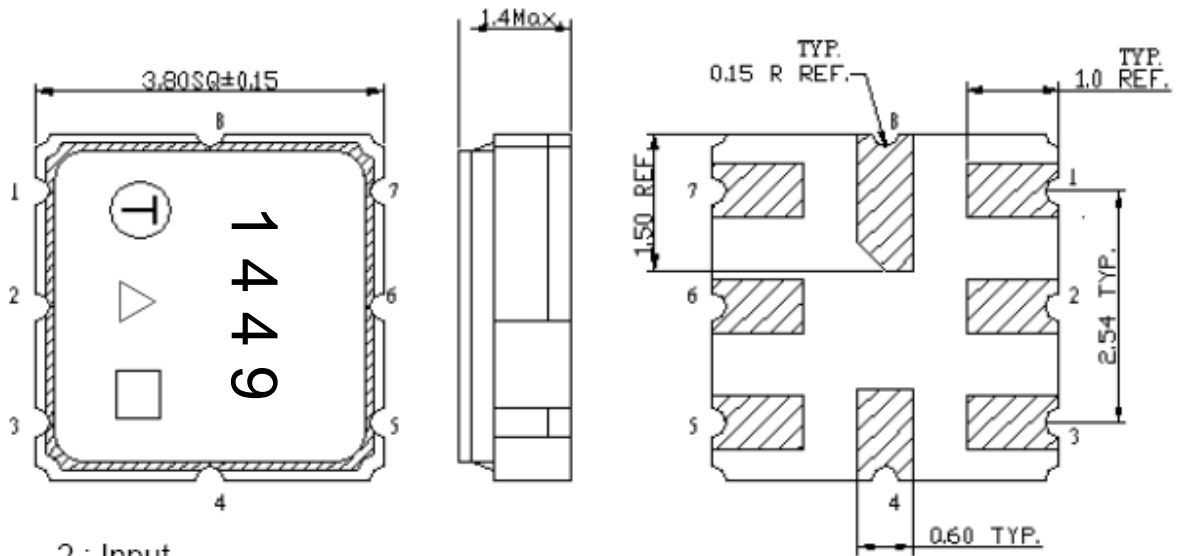

- 2 : Input
- 6: Output
- 1,3,4,5,7,8: Ground
- △ : Year Code
- : Date Code (W01->A, W02->B, ..., W52->z)

△ Product Year Code

Year	2011	2012
	2013	2014
	2015	2016
	2017	2018
	Product Code	A

E. PCB Footprint:

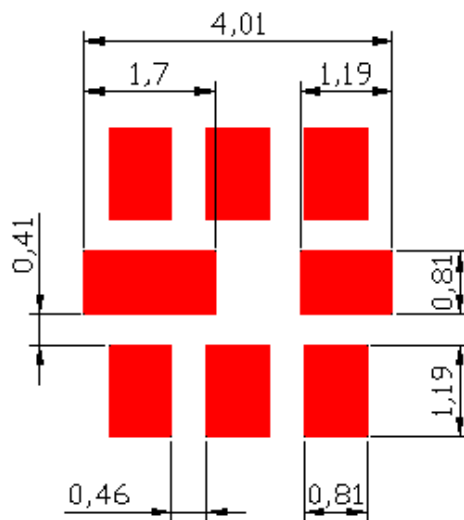

F. Frequency Characteristics:

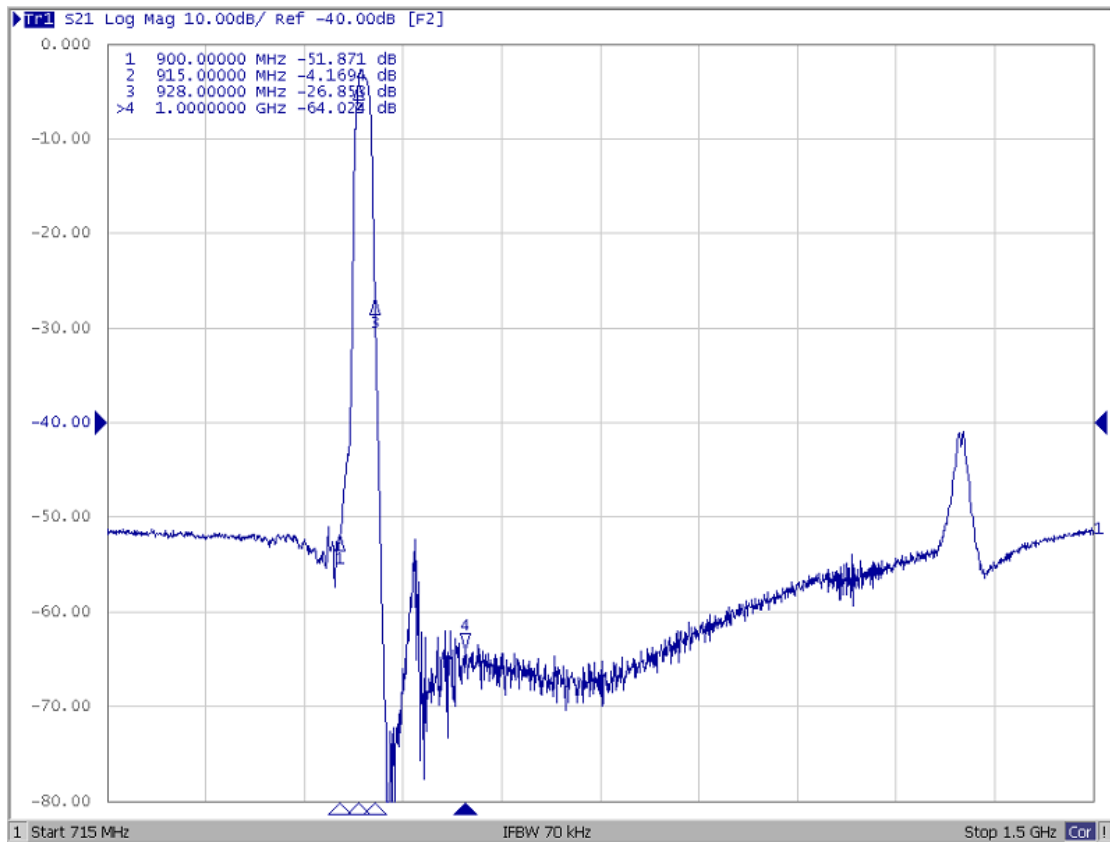
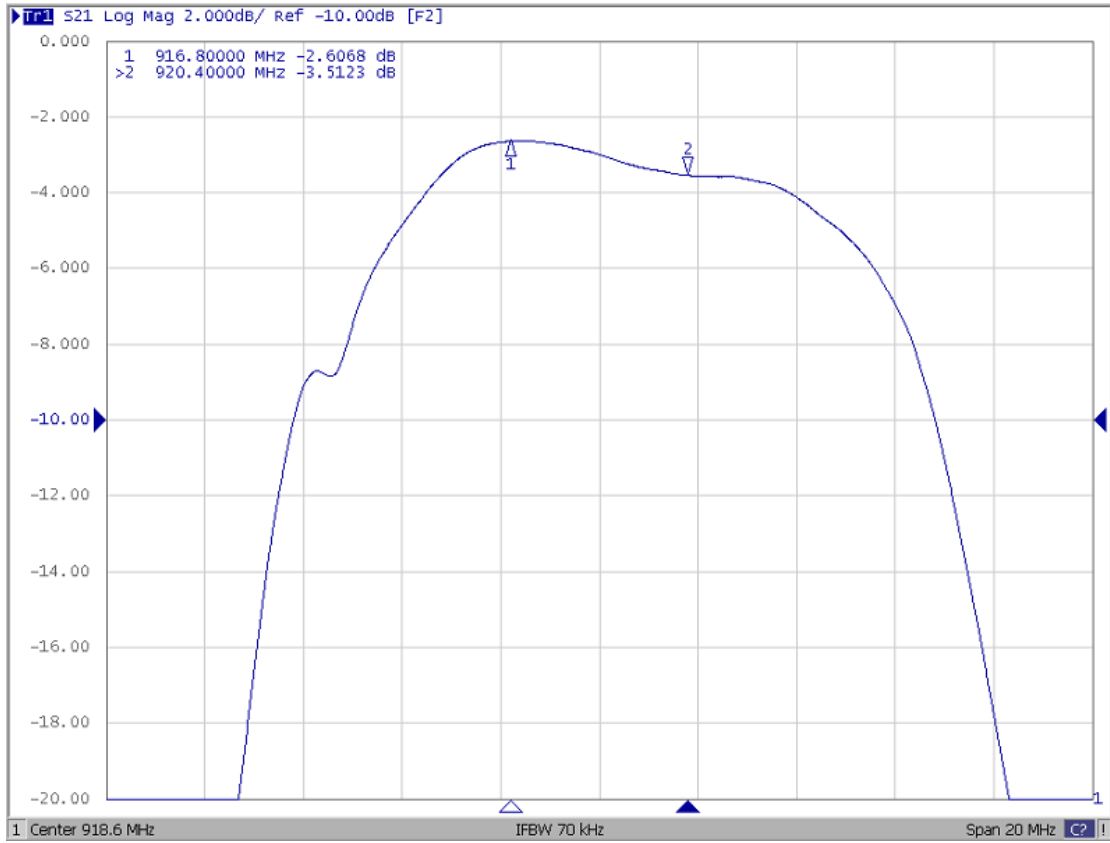

G. PACKING:

1. REEL DIMENSION

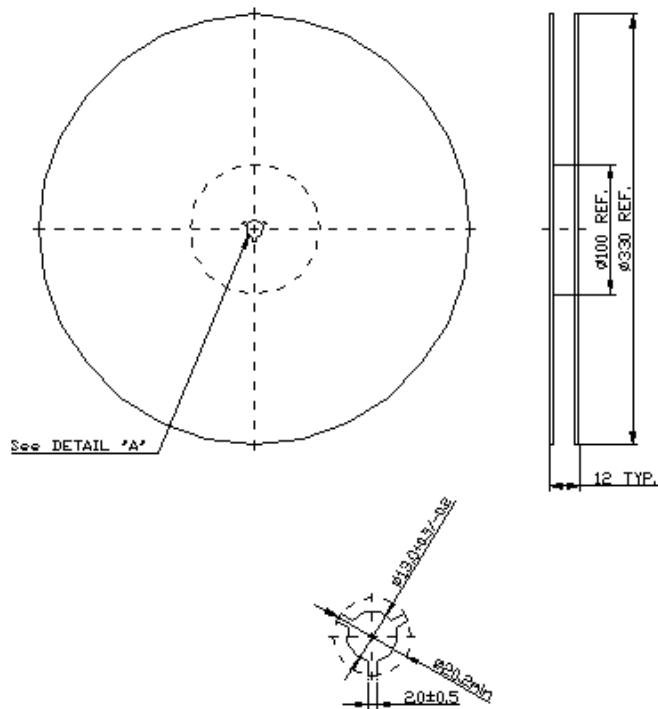

2. TAPE DIMENSION

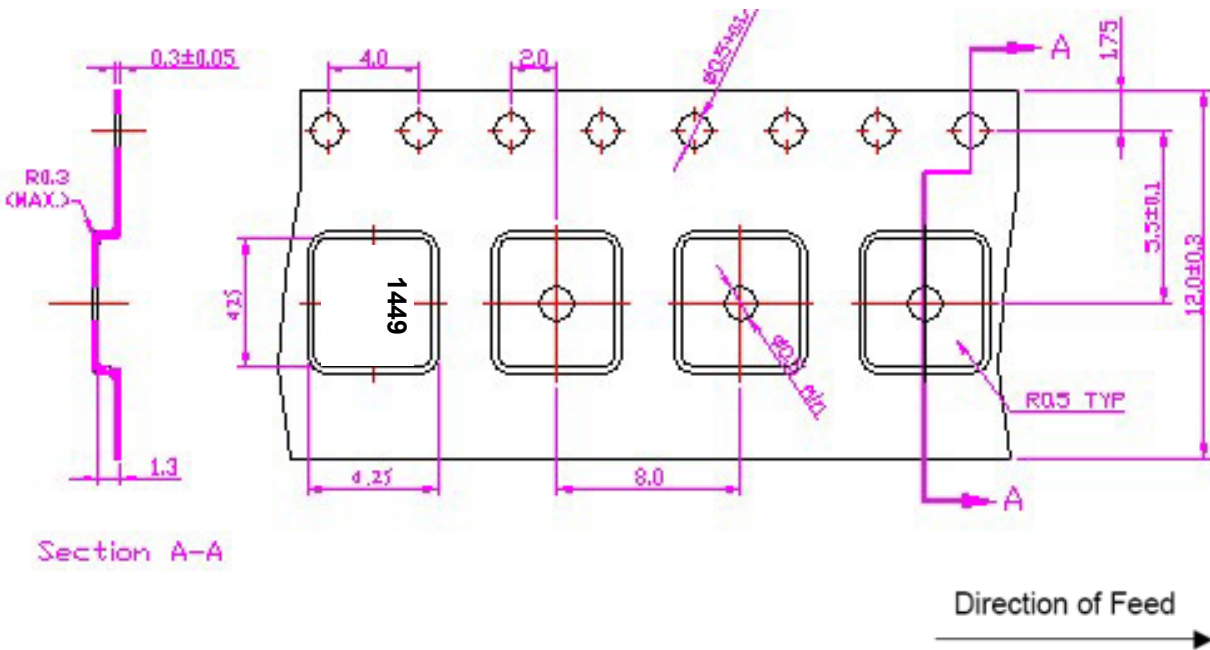

H. RECOMMENDED REFLOW PROFILE:

