

主要参数:

1. 额定电压. 电流: 125V/1.5A max
2. 接触电阻: 40m Ω Max 初始态
100 Ω Max 最终态
3. 绝缘电阻: 500M Ω Min
4. 试验条件: DC500V/5.0mA for 1 minute
5. 盐雾测试: 8±0.5H
6. 焊接温度: 260±5℃ 3±0.5S
7. 工作温度: -40℃ to 80℃

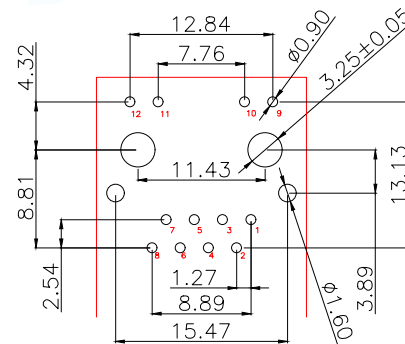

RECOMMENDED PCB LAYOUT

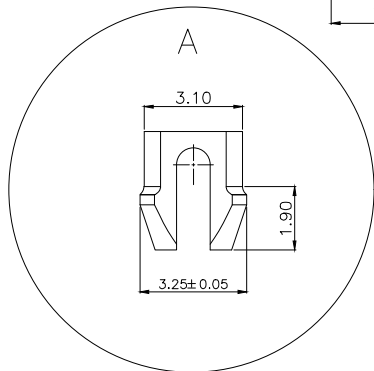

LED	L-绿 R-黄	镀锡	
屏蔽	T0.17mm黄铜	镀镍	
PIN脚	T0.46mm磷铜	镀金	
基座	尼龙	黑(环保)	
名称	材料	电镀/颜色	备注

MANUFACTURE DWG			东莞市讯普电子科技有限公司 DongGuan XunPu Electronics Co.,Ltd	
UNLESS OTHERWISE SPECIFIED TOLERANCES			TITLE: RJ45带灯屏蔽 DIP	
DECIMALS:	ANGLES:	PAR	RJ45-408-049-12	
.X:±0.30	X':±3°	DWN		
.XX:±0.25	.X':±2°	CHKD		
.XXX:±0.10	.XX':±1°	APVD		
CUSTOMER COPY		SCALE:1:1	UNIT:MM	REV:A
		SIZE:A4	SHEET:1F1	