

GENERAL DESCRIPTION

OB3335x is a TRIAC dimmable high power factor, low THD, highly integrated buck-boost/flyback regulator with advanced features to provide high efficiency control and high precision constant current output for dimmable LED lighting applications.

Without external large compensation capacitor, the system can achieve high power factor and low THD with proprietary PFC control scheme.

OB3335x offers comprehensive protection coverage with auto-recovery features including LED open loop protection, LED short circuit protection, cycle-by-cycle current limiting, built-in leading edge blanking, VDD under voltage lockout (UVLO), thermal foldback etc.

OB3335x is offered in SOP-7 package.

FEATURES

- Excellent TRIAC dimming performance
- Low system cost and high efficiency
- Without external power supply circuit
- High PF (PF>0.9) @90~132Vac input
- Low THD (THD<10%) @90~132Vac input
- NEMA SSL6 Dimming Curve compliant
- High precision constant current regulation at universal AC input
- Quasi-Resonant operation
- Thermal foldback function for LED output current control and Over temperature protection (OTP)
- LED short circuit protection
- LED open loop protection
- Cycle-by-cycle current limiting
- Built-in leading edge blanking (LEB)
- VDD under voltage lockout with hysteresis

APPLICATIONS

- Dimmable LED lighting

Typical Application for Buck-Boost Topology

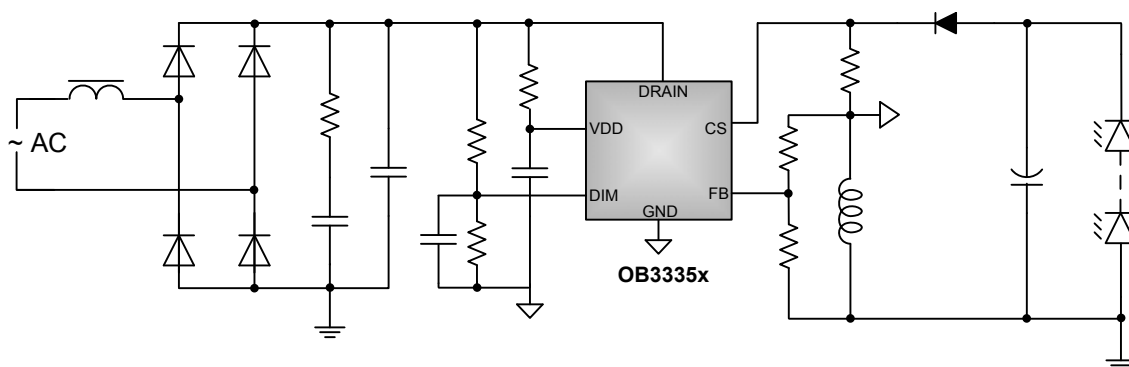

GENERAL INFORMATION

Pin Configuration

The pin map is shown as below.

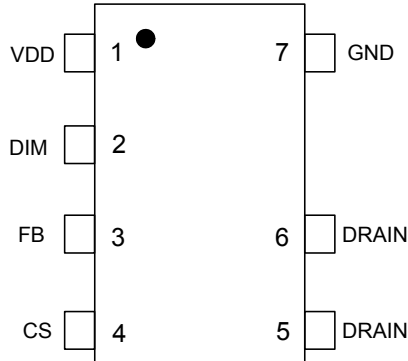

Ordering Information

Part Number	Description
OB3335UJP-F	SOP7, Halogen-free in Tube
OB3335UJPA-F	SOP7, Halogen-free in T&R
OB3335TJP-J	SOP7, Halogen-free in Tube
OB3335TJPA-J	SOP7, Halogen-free in T&R

Note: All Devices are offered in Halogen-free Package if not otherwise noted.

Package Dissipation Rating

Package	R θ JA (°C/W)
SOP7	95°C/W

Recommended Operating Condition

Symbol	Parameter	Range
VDD	VDD Supply Voltage	8 to 16V

Absolute Maximum Ratings

Parameter	Value	
VDD Voltage	-0.3 to 20V	
CS Input Voltage	-0.3 to 7V	
FB/DIM Input Voltage	-0.3 to 7V	
Drain voltage	OB3335UJPA-F	-0.3 to 300V
	OB3335TJPA-J	-0.3 to 500V
Min/Max Operating Junction Temperature T _J	-40 to 150 °C	
Operating Ambient Temperature T _A	-40 to 85 °C	
Min/Max Storage Temperature T _{stg}	-55 to 150 °C	
Lead Temperature (Soldering, 10secs)	260 °C	

Note: Stresses beyond those listed under "absolute maximum ratings" may cause permanent damage to the device. These are stress ratings only, functional operation of the device at these or any other conditions beyond those indicated under "recommended operating conditions" is not implied. Exposure to absolute maximum-rated conditions for extended periods may affect device reliability.

Output Power Table

Product	Condition	90Vac~132Vac Input
OB3335U	I _o ≤ 0.25A	14W
OB3335T	I _o ≤ 0.25A	10.5W

Note: Maximum practical continuous power in an open frame design with sufficient drain pattern as a heat sink, at 50°C ambient and 60°C temperature rise. Higher output power is possible with extra added heat sink, air circulation and decrease output current to reduce thermal resistance.

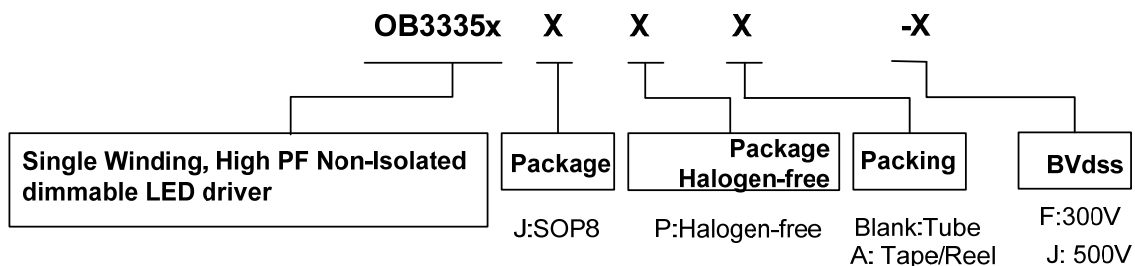

Marking Information

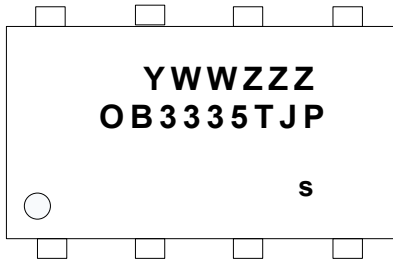

Y: Year Code
 WW: Week Code (01-52)
 ZZZ: Lot Code
 C: SOP8
 P: Halogen-free Package
 S: Internal Code(Optional)

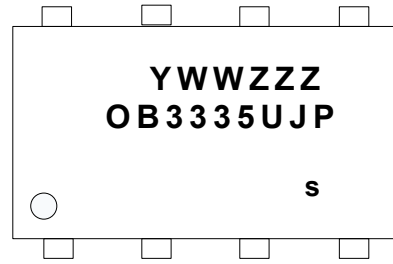

Y: Year Code
 WW: Week Code (01-52)
 ZZZ: Lot Code
 C: SOP8
 P: Halogen-free Package
 S: Internal Code(Optional)

Terminal Assignments

Pin Num	Pin Name	I/O	Description
1	VDD	P	Power supply input.
2	DIM	I/O	Dimming control input
3	FB	I/O	Over voltage protection& demag detect
4	CS	I/O	Current sensing terminal.
5/6	DRAIN	I/O	Drain of internal power MOS
7	GND	P	Power Ground.

BLOCK DIAGRAM

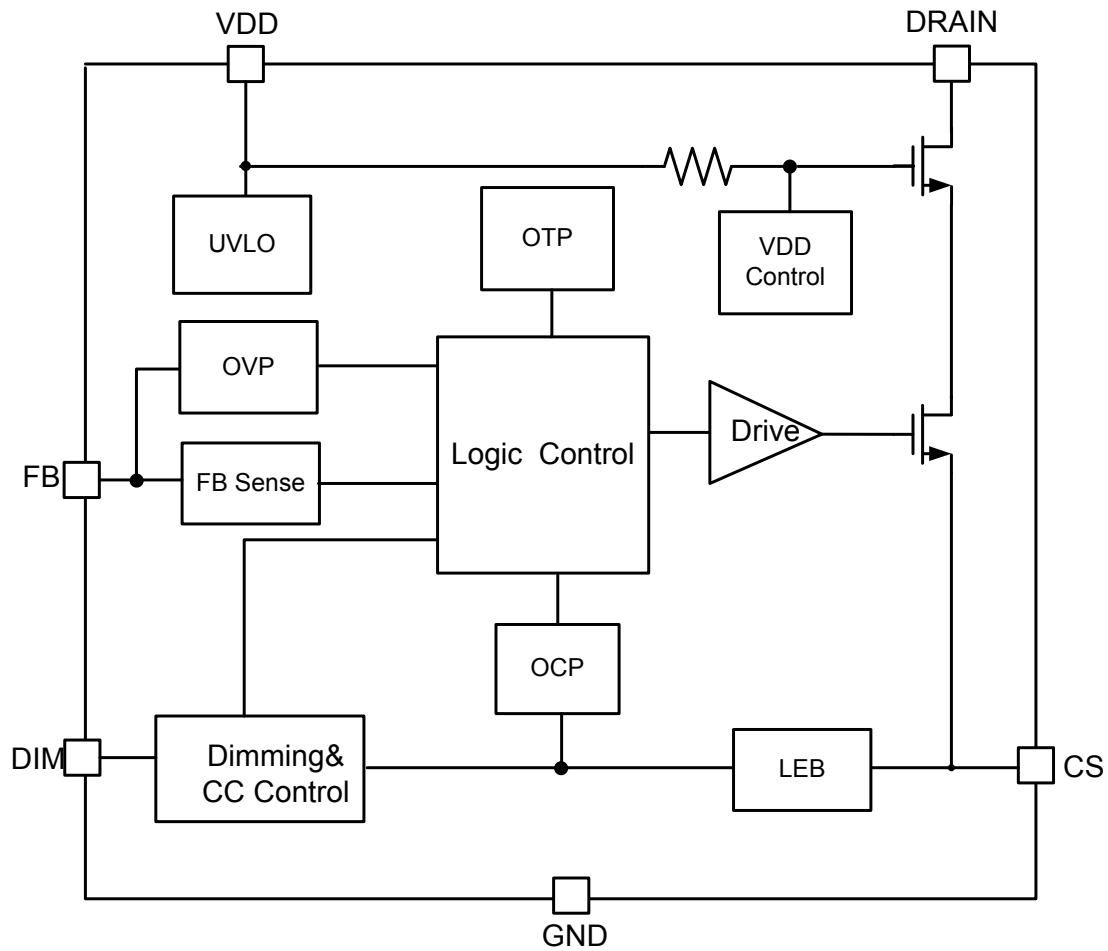

ELECTRICAL CHARACTERISTICS

(TA = 25°C, VDD=14V, if not otherwise noted)

Symbol	Parameter	Test Conditions	Min	Typ.	Max	Unit
Supply Voltage (VDD) Section						
I _{start-up}	Start up current	VDD=UVLO(OFF)-1V	136	170	204	uA
I _{op}	Operation current	VDD=14V, no loading		350	420	uA
UVLO(OFF)	VDD under voltage lockout exit			13		V
UVLO(ON)	VDD under voltage lockout enter			6.5		V
VDD_clamp	VDD CLAMP	VDD current 1mA		16		V
IVDD_clamp	VDD clamp current			30	35	mA
Current Sense Input Section						
TLEB	LEB time			0.4		us
V _{th_ocp1}	Over Current Threshold at Normal operation			1		V
V _{th_ocp2}	Over Current Threshold at LED short			0.5		V
FB Input Section						
V _{th_ovp}	Output Over Voltage Protection		1.9	2	2.1	V
QR Section						
F _{max}	Maximum Working Frequency			600		KHz
T _{off_max}	Maximum Off Time		30	35	40	us
T _{off_min}	Minimum Off Time			2		us
T _{on_max}	Maximum On Time		11	12	13	us
Error Amplifier Section						
V _{ref}	Error Amplifier Reference Voltage		0.196	0.200	0.204	V
OTP Section						
OTP	Over temperature protection			165		°C
Hysteresis				50		°C
T _{TF}	Thermal regulation threshold			140		°C

CHARACTERIZATION PLOTS

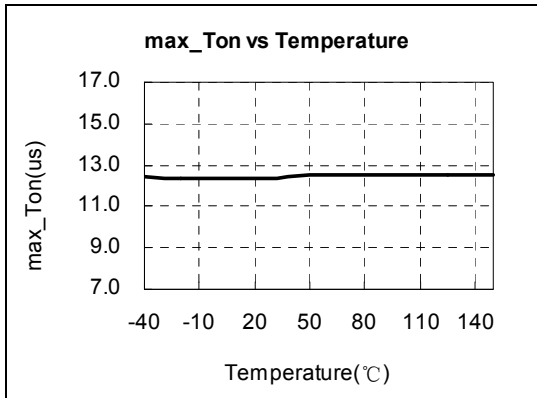
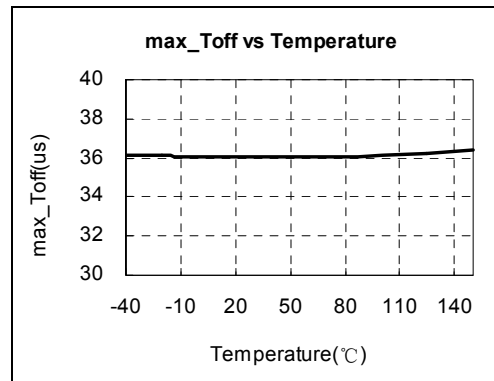
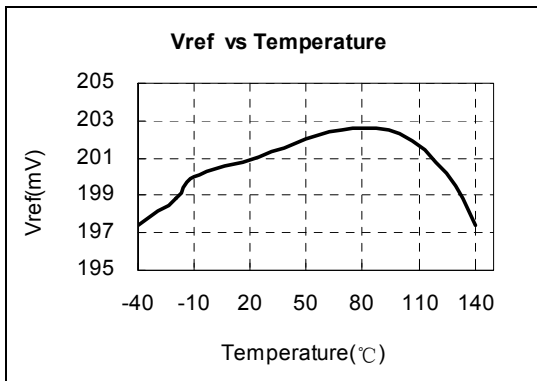
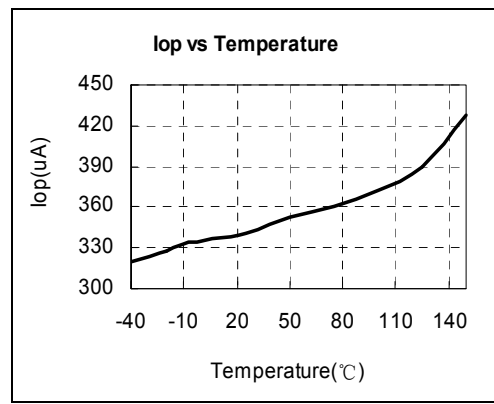
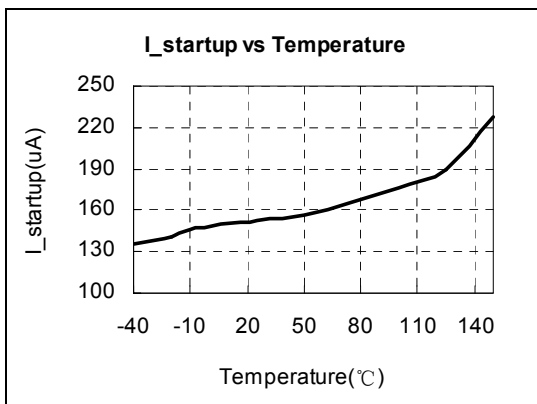
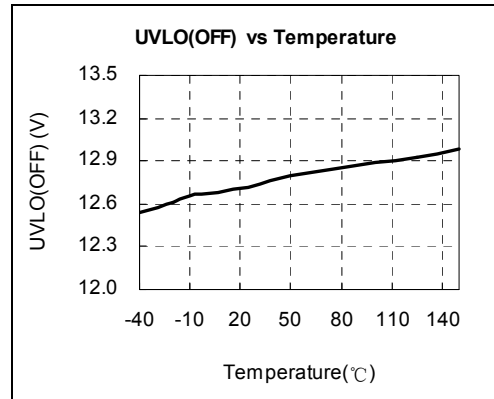
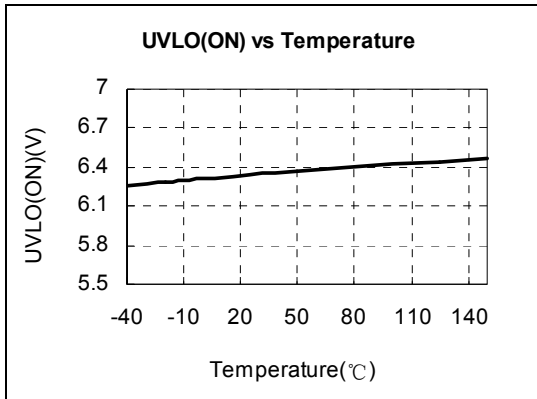

OPERATION DESCRIPTION

OB3335x is a TRIAC dimmable high power factor, low THD, low operation current, highly integrated buck-boost/flyback regulator with advanced features to provide high efficiency control and high precision constant current output for LED lighting applications.

Start up Control

Startup process is realized by charging VDD capacitor. When VDD voltage reaches up to UVLO(OFF), the system starts to operate. A 16V (typical) clamp circuit is applied to clamp VDD voltage.

LED Constant Current Regulation

OB3335x uses the constant current control method to accurately control the LED current. It detects LED current and forces the average LED current equals to the ratio of reference voltage to resistance at CS pin as shown in the equation below.

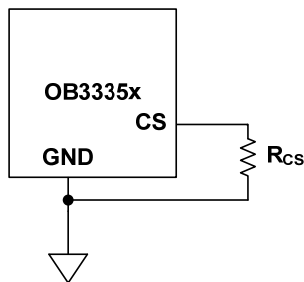

Figure1 CS Section Circuit

$$I_{LED} (mA) = \frac{V_{ref} (mV)}{2R_{CS} (\Omega)}$$

Rcs — The sensing resistor connected between the CS pin and the GND pin of IC.

Vref — Internal reference voltage.

PFC&THD

The duration of the turn on period t_{on} is generated by comparing an internal fixed saw-tooth wave with the voltage on the internal CMP. During steady state operation, the voltage on the CMP (V_{cmp}) is slowly varying due to very Low gm of EA, therefore the turn on time t_{on} is constant. In a buck-boost/flyback topology, constant turn on time and quasi-resonant operation provide high power factor (PF) and low total harmonic distortion (THD).

Dimming control

OB3335x measuring the phase-cut mains voltage using the DIM pin, the DIM voltage control the internal reference voltage of EA. The dimmed current I_{dim_out} can compliant NEMA SSL6 Dimming Curve.

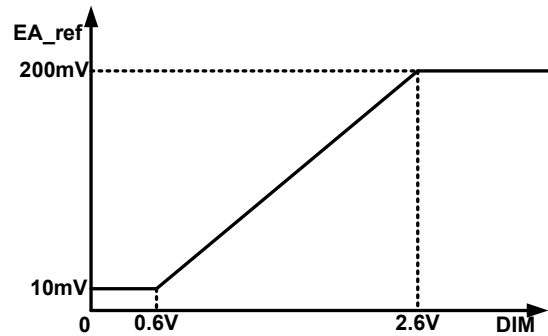

Figure2 dimming control transfer function

Current Sensing and Leading Edge Blanking

Cycle-by-Cycle current limiting (OCP) is offered in OB3335x. The current is detected by a sense resistor connected between the CS pin and GND. An internal leading edge blanking circuit chops off the sense voltage spike at initial MOSFET on state due to wheel diode reverse recovery. The current limiting comparator is disabled at this blanking time and thus the MOSFET cannot be turned off during this blanking time.

LED Open/Output OVP Protection

When LED string is open, an output over-voltage condition is monitored independently by the voltage at pin FB. During normal operation, when the voltage at FB pin exceeds a threshold of approximately 2V (typical), the over-voltage protection function is activated and the switching is turned off immediately.

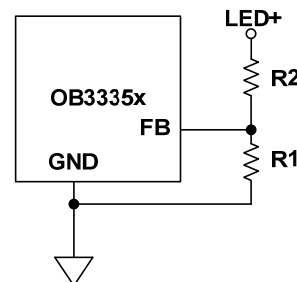

Figure3 FB Section Circuit

$$V_{OVP} = \frac{R1 + R2}{R1} \times V_{th_ovp}$$

R1 — The resistor connected between the FB pin and the GND pin of IC, the value suggested is 5Kohms~15Kohms

R2 — The resistor connected between the FB pin and the Output, the value suggested is 330Kohms~1Mohms

After LED open is generated, the timer is started and thus the IC enters Hiccup mode. After 570ms (typical) the LED open state will be reset and internal MOS are allowed to turn on.

LED Short Circuit Protection

When LED string short circuit occurs, OB3335x detects the voltage at FB pin is lower than a threshold of approximately 0.45V (typical), the OCP threshold is reduced to 0.5V, After 150ms, the gate of OB3335x is turned off and the timer is started, thus the IC enters Hiccup mode. After 570ms (typical) the LED short state will be reset

Thermal foldback & Thermal Shutdown

OB3335x provides thermal foldback function to control LED output current. It reduces the output current when temperature reaches 140°C (typical)

by adjusting the reference of EA. The LED current will reduce with the temperature rise up.

When temperature rises above 165°C (typical), switching will be stopped due to OTP protection. The normal operation is resumed when the temperature falls below 115 °C (typical) . Between the temperature of 140°C (typical) and 165 °C (typical), the output current follows the thermal foldback function scheme. When the temperature is below 140°C (typical), the output current returns to the full level.

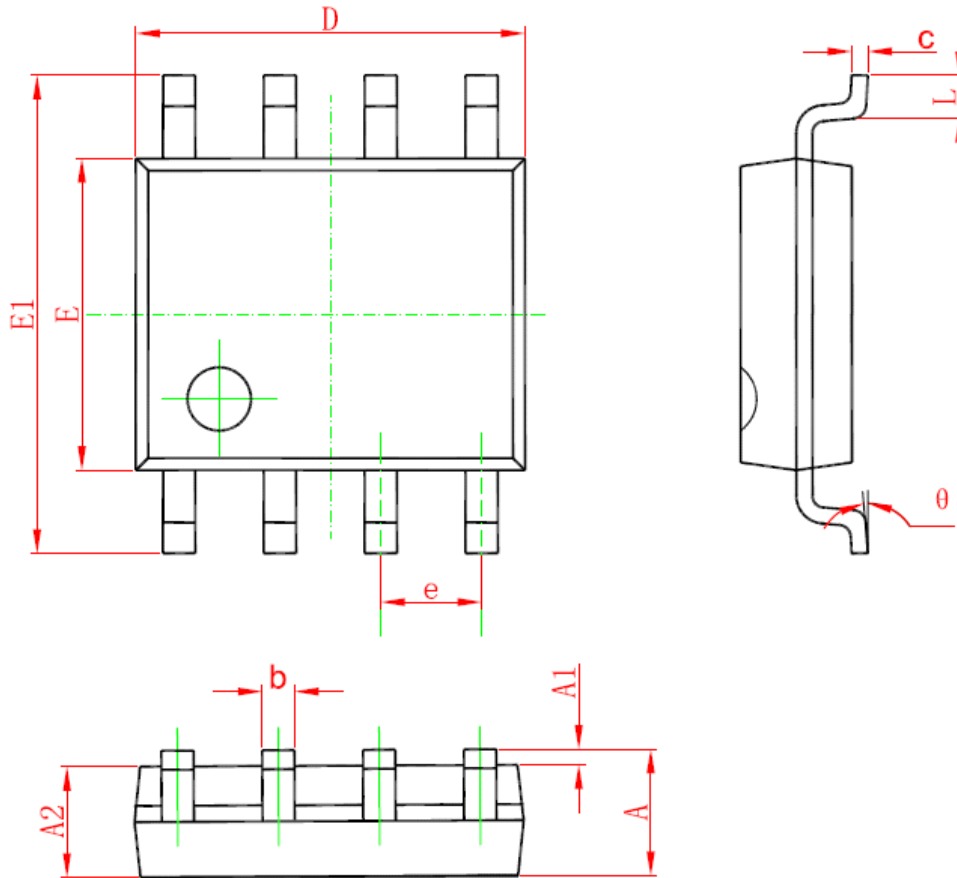
PACKAGE MECHANICAL DATA SOP7/SOP8
SOP8 PACKAGE OUTLINE DIMENSIONS

Symbol	Dimensions In Millimeters		Dimensions In Inches	
	Min	Max	Min	Max
A	1.350	1.750	0.053	0.069
A1	0.050	0.250	0.002	0.010
A2	1.250	1.650	0.049	0.065
b	0.310	0.510	0.012	0.020
c	0.100	0.250	0.004	0.010
D	4.700	5.150	0.185	0.203
E	3.800	4.000	0.150	0.157
E1	5.800	6.200	0.228	0.244
e	1.270 (BSC)		0.050 (BSC)	
L	0.400	1.270	0.016	0.050
θ	0°	8°	0°	8°

IMPORTANT NOTICE**RIGHT TO MAKE CHANGES**

On-Bright Electronics Corp. reserves the right to make corrections, modifications, enhancements, improvements and other changes to its products and services at any time and to discontinue any product or service without notice. Customers should obtain the latest relevant information before placing orders and should verify that such information is current and complete.

WARRANTY INFORMATION

On-Bright Electronics Corp. warrants performance of its hardware products to the specifications applicable at the time of sale in accordance with its standard warranty. Testing and other quality control techniques are used to the extent it deems necessary to support this warranty. Except where mandated by government requirements, testing of all parameters of each product is not necessarily performed.

On-Bright Electronics Corp. assumes no liability for application assistance or customer product design. Customers are responsible for their products and applications using On-Bright's components, data sheet and application notes. To minimize the risks associated with customer products and applications, customers should provide adequate design and operating safeguards.

LIFE SUPPORT

On-Bright Electronics Corp.'s products are not designed to be used as components in devices intended to support or sustain human life. On-bright Electronics Corp. will not be held liable for any damages or claims resulting from the use of its products in medical applications.

MILITARY

On-Bright Electronics Corp.'s products are not designed for use in military applications. On-Bright Electronics Corp. will not be held liable for any damages or claims resulting from the use of its products in military applications.