

深圳扬兴科技有限公司

产 品 规 格 书

SPECIFICATION

产品名称	石英晶体振荡器 QUARTZ CRYSTAL OSCILLATOR
型 号	YSO110TR
料 号	OT2JI-111-8.192M
参数描述	SMD-3225-8.192MHZ-1.8V-3.3V- +/-10PPM
页 次	共7页

确 认 签 章

客 户		
客户物料号		
机种/型号		
批 准	审 核	检 验

扬 兴 签 核

制 定	审 核	批 准
朱灿维		

深圳扬兴科技有限公司

Shenzhen YangXing Technology Co.,Ltd.

地址：深圳市龙华区民治街道民塘路385号汇德大厦1号楼19层

ADDRESS: 19th Floor, 1st Huide Building, Mintang Rd No.385, Longhua District, Shenzhen

TEL: 0755-28444777

WEB: <http://www.yxc.hk>



REV. 版本	Description of Revision History 修改内容	Date 日期	Engineer 工程师	Reviewer 审核
A.0	新版页面修改	2020/11/11	马占军	蔡荣洪
B.0	新版页面修改，变更工程师 审核人员	2022/3/1	康明红	马占军

MHz Range Crystal unit

YSO110TR

Product name 系列型号

YSO110TR 8.19200MHZ 1.8V-3.3V +/-10PPM

Product Number / Ordering code 产品料号 OT2JI-111-8.192M

1.Specifications (电气参数)

Supply Voltage	1.8~3.3V
Frequency	8.192MHz
Current Consumption	5mA
Frequency Tolerance(at 25°C)	±10ppm
Frequency Tolerance VS operating temperature	±20ppm
Output Load	15pF
Operating Temperature Range	-40~+85°C
Storage Temperature Range	-55~+125°C
Voltage Vol (Max.) / Vol (Min.)	VOH = 90%Vdd/VOL = 10%Vdd
Duty Cycle	45~55%
Start-up Time	3ms Max
Rise/Fall Time	4nS Max.
Frequency Aging (at 25°C)	±3 ppm / year Max.

2.External dimensions (外观尺寸 (Unit: mm))

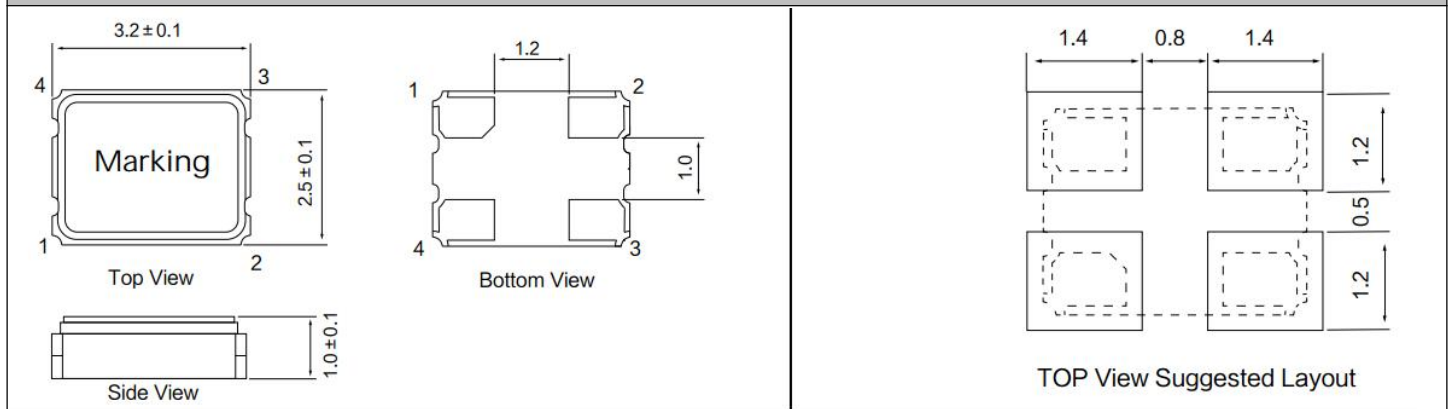

Pin Dimension

Pin	#1	#2	#3	#4
FUNCTION	Tri-state	GND	OUTPUT	VDD

Pin Assignments

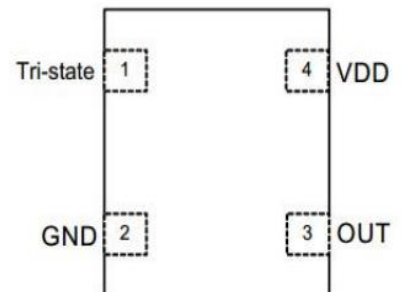

*右图仅供PIN功能说明

3.Marking information(丝印说明)

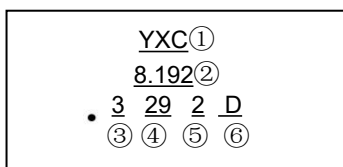

- ① YangXing LOGO
- ② Frequency
- ③ Year
- ④ The production cycle
- ⑤ Line
- ⑥ Voltage+Operating Temperature

4.Taping Specification (载带规格) (Unit: mm)

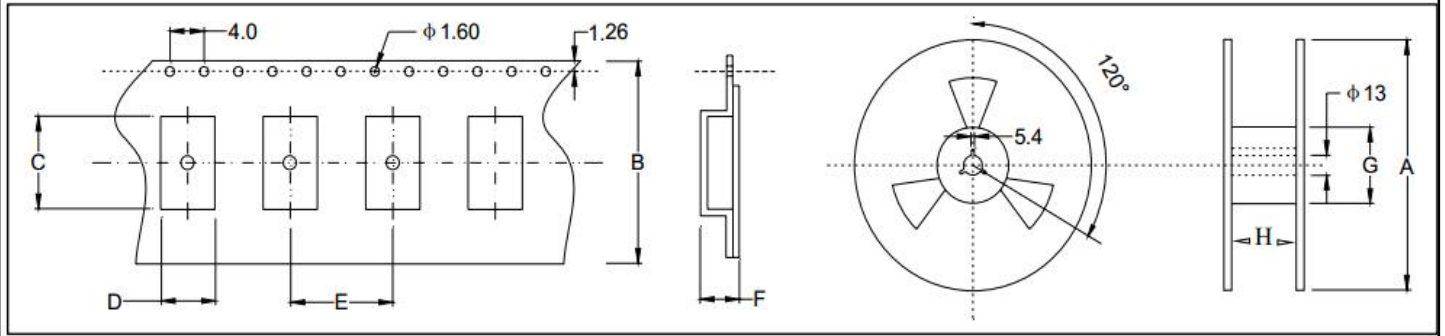

Size	A	B	C	D	E	F	G	H
SMD-3225	180±2.0	8.0±0.3	3.40±0.1	2.70±0.1	4.0±0.1	1.50±0.1	61.0±1.0	8.0±1.0

3000 pcs per reel

5.Reliability characteristic (可靠性)

NO (序号)	Item (项目)	Condition (环境条件)	Reference (参考标准)	Specifications (说明)
5.1	Solderability (可焊性)	Solder bath temperature:260°C,dwell time:5 seconds,Solder: 100% tin	IEC68-2-20:1979	A new uniform coating of solder shall cover a minimum of 95% of the surface being immersed.
5.2	Resistance to soldering heat (焊接耐热性)	Solder temperature 260+/-5°C,Immersion time:10 S Solder bath composition:100% tin	IEC68-2-58:1989	$\Delta F \leq +/-5\text{ppm}$
5.3	Vibration (机械振动)	The entire frequency range: 10Hz to 55Hz ,Amplitude:1.5mm This motion shall be applied for a period of 2 h in each of 3 mutually perpendicular axes(a total of 6h)	IEC 68-2-21:1992	$\Delta F \leq +/-5\text{ppm}$
5.4	Drop test (跌落测试)	Drop from 75cm height on 3cm hard wooden board for 6 times	IEC68-2-32:1990	$\Delta F \leq +/-5\text{ppm}$
5.5	Cold Storage (低温储存)	The quartz crystal unit shall be stored at a temperature of -40+/-3°C for 1000 h.then it shall be subjected to standard atmospheric conditions for 1h after which measurement shall be made.	IEC68-2-6:1982	$\Delta F \leq +/-5\text{ppm}$
5.6	High temperature High humidity storage(steady state) (高温高湿度储存)	The quartz crystal unit shall be stored at a temperature of 40+/-2°C with relative humidity of 95% for 1000h, then it shall be subjected to standard atmospheric conditions for 2h after which measurement shall be made.	IEC60068-2-1:1990	$\Delta F \leq +/-5\text{ppm}$

5.7	Thermal shock (温度冲击测试)	<p>The quartz crystal unit shall be subjected to 50 successive Change of temperature cycles. Each as shown in table below ,then it shall be subjected to standard atmospheric conditions for 1h after which measurement shall be made.</p> <table border="1" data-bbox="464 389 1043 533"> <thead> <tr> <th>NO</th> <th>Temperature</th> <th>Duration</th> </tr> </thead> <tbody> <tr> <td>1</td> <td>-40+/-3°C</td> <td>15minutes</td> </tr> <tr> <td>2</td> <td>105+/-2°C</td> <td>15minutes</td> </tr> <tr> <td>3</td> <td>Transition time</td> <td>Within 10 seconds</td> </tr> </tbody> </table>	NO	Temperature	Duration	1	-40+/-3°C	15minutes	2	105+/-2°C	15minutes	3	Transition time	Within 10 seconds	IEC68-2-14:1986	$\Delta F \leq \pm 5 \text{ppm}$
NO	Temperature	Duration														
1	-40+/-3°C	15minutes														
2	105+/-2°C	15minutes														
3	Transition time	Within 10 seconds														
5.8	Sealing (气密性)	Helium leakage detector shall used to measure the leakage rate of gas through any faulty seal. Pressure:500Kpa, duration:120 minutes.	IEC68-2-3:1984	Leakage rate $\leq 1 * 10^{-9} \text{ Pa.m}^3/\text{S}$												
5.9	High temperature Life test (高温储存测试)	The quartz crystal unit shall be stored at a temperature of 105+/-3°C for 168h ,then it shall be subjected to standard atmospheric condition for 1h after which measurement shall be made.	IEC60068-2-2:1974	$\Delta F \leq \pm 5 \text{ppm}$												

6.Reflow profile (回流焊)

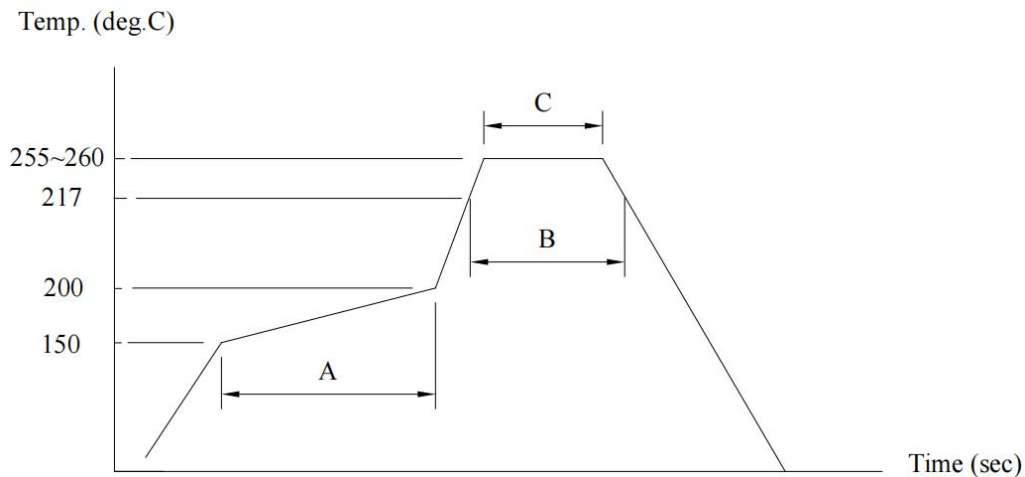

- (A)→Preheating area : 150~200°C, 60~120sec.
- (B)→Heating area : 217°C, 60~150sec.
- (C)→Peak temperature : 255~260°C, 30sec. Max.
- Ramp-up rate (217→260°C) : 3°C/sec. Max.
- Ramp-down rate (260→217°C) : 6°C/sec. Max.
- Time 25°C→260°C : 480sec. Max.
- Moisture Sensitivity Level : Level1

7. Notice (注意)

- 包装 PACKING
- 包装方式应符合运输和装卸要求，特殊包装须经双方认可。
- Packing must prevent damage during transportation and handing. Specific method will be settled by mutual agreement.
- 对环境影响 INFLUENCE TO ENVIRONMENT
- 本产品在生产过程中不使用 ODS I，对臭氧层无破坏。
- This product doesn't use the class I ODS at any of production process .
- 生产厂家 MANUFACTURE
- 公司名称：深圳扬兴科技有限公司
- Shenzhen YangXing Technology Co.,Ltd.
- 其它 OTHERS
- 1. 如果您对本公司产品规格书有疑问或书中未列出，请与我方联系，协商解决及改进。
- If you have some doubt or unknowing about this specification, Please contact us for settlement or development.
- 2. 我们按照产品规格书要求保证晶体品质，若客户要求具体数据，我们可提供。
- We guarantee that quartz crystal unit satisfies this specification, If you need the data, we will provide it.
- 3. 变更与联络 (MODIFY AND CONTACT)
- 本产品在设计、工艺、材料、生产厂所、关键设备、操作人员等影响产品质量的因素有变更时，应事先提供更改后的产品并经过质量认可后，方可大批量供货。
- When the quality is changed due to the changes of the design, technology, material, manufacture place, main equipment and workers, we will first supply the modified products and obtain approval from you, then start to supply mass production.
- 4. 售前售后服务 (AFTER SALE SERVICE)
- 若在生产过程中遇到不良品，本公司负责调换，并及时提交不良品的分析及改进措施报告经认可。
- If the defection product was found in the production process, we will exchange and provide the improving measures in time.

Contact us

www.yxc.hk