

MMDTC143ZE

NPN Silicon Epitaxial Planar Digital Transistor

Features

- With built-in bias resistors
- Simplify circuit design
- Reduce a quantity of parts and manufacturing process

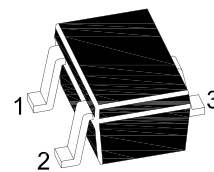
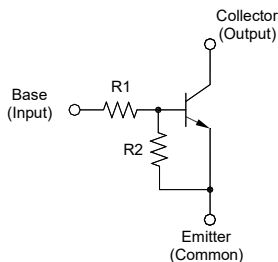

1.Base 2.Emitter 3.Collector
SOT-523 Plastic Package

Absolute Maximum Ratings ($T_a = 25\text{ }^\circ\text{C}$)

Parameter	Symbol	Value	Unit
Collector Emitter Voltage	V_{CEO}	50	V
Input Voltage	V_I	- 10 to + 40	V
Collector Current	I_c	100	mA
Power Dissipation	P_{tot}	150	mW
Junction Temperature	T_j	150	$^\circ\text{C}$
Storage Temperature Range	T_{stg}	- 55 to + 150	$^\circ\text{C}$

Thermal Characteristics

Parameter	Symbol	Max.	Unit
Thermal Resistance from Junction to Ambient ¹⁾	$R_{\theta JA}$	833	$^\circ\text{C/W}$

¹⁾Device mounted on FR-4 substrate PC board, with minimum recommended pad layout.

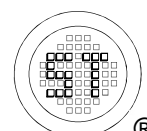

MMDTC143ZE

Characteristics at $T_a = 25\text{ }^\circ\text{C}$

Parameter	Symbol	Min.	Typ.	Max.	Unit
DC Current Gain at $V_{CE} = 5\text{ V}$, $I_C = 10\text{ mA}$	h_{FE}	80	-	-	-
Collector Base Cutoff Current at $V_{CB} = 50\text{ V}$	I_{CBO}	-	-	0.1	μA
Emitter Base Cutoff Current at $V_{EB} = 5\text{ V}$	I_{EBO}	-	-	1.8	mA
Collector Emitter Saturation Voltage at $I_C = 5\text{ mA}$, $I_B = 0.25\text{ mA}$	$V_{CE(sat)}$	-	-	0.25	V
Input on Voltage at $V_{CE} = 0.3\text{ V}$, $I_C = 5\text{ mA}$	$V_{I(on)}$	-	-	1.3	V
Input off Voltage at $V_{CE} = 5\text{ V}$, $I_C = 100\text{ }\mu\text{A}$	$V_{I(off)}$	0.5	-	-	V
Transition frequency at $V_{CE} = 10\text{ V}$, $-I_E = 5\text{ mA}$, $f = 100\text{ MHz}$	f_T	-	250	-	MHz
Input Resistance	R_1	3.29	4.7	6.11	$\text{K}\Omega$
Resistance Ratio	R_2 / R_1	8	10	12	-

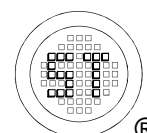

MMDTC143ZE

Electrical Characteristic Curves

Fig. 1 Output Characteristics Curve

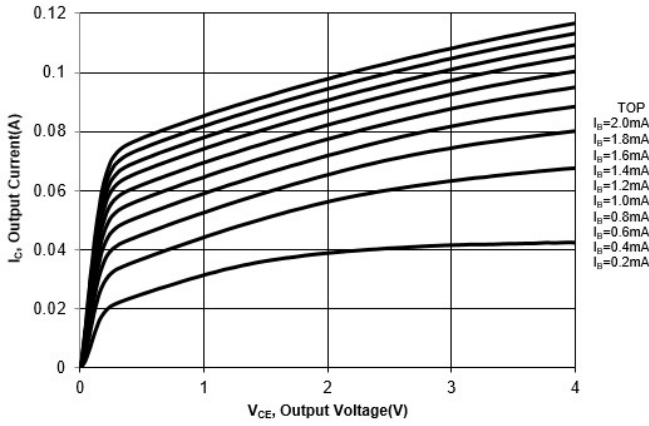

Fig. 2 Output Current vs. $V_{I(ON)}$ Input Voltage

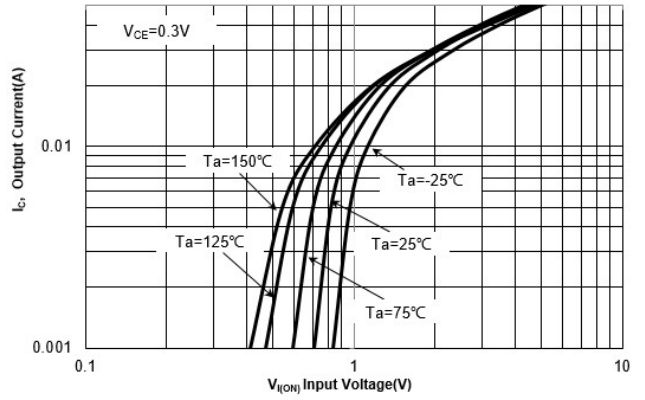

Fig. 3 Output Current vs. $V_{I(OFF)}$ Input Voltage

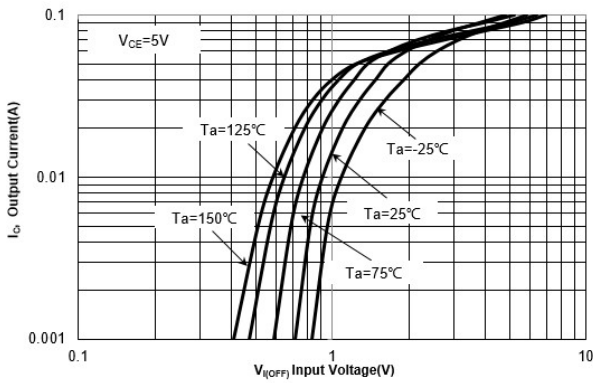

Fig. 4 $h_{FE,DC}$ Current Gain vs. Output Current

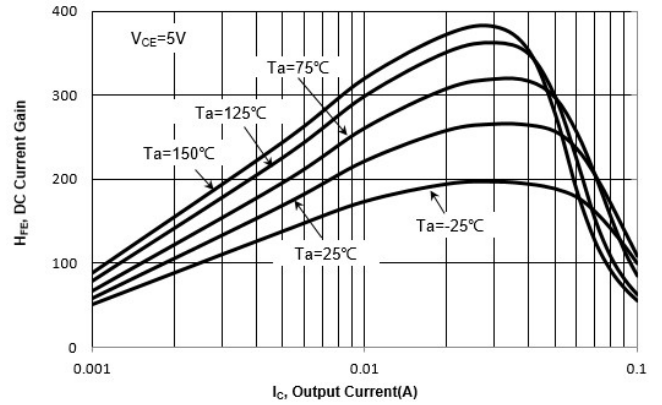

Fig. 5 $V_{CE(sat)}$ vs. Output Current

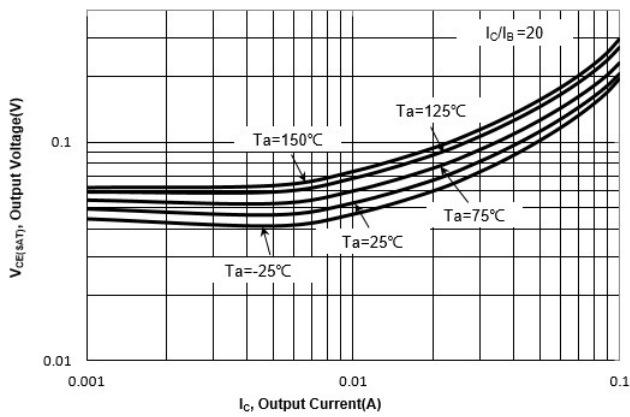
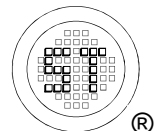
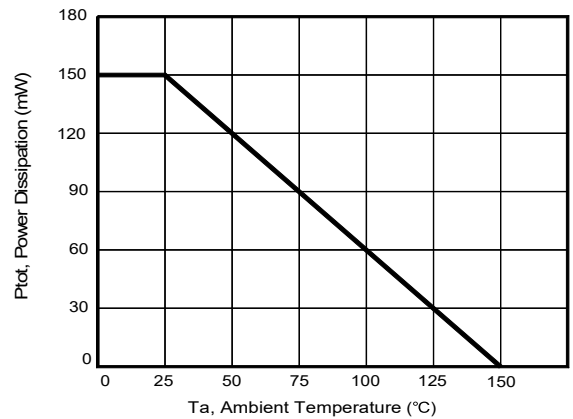

Fig. 6 Power Derating Curve



MMDTC143ZE

Package Outline (Dimensions in mm)

SOT-523

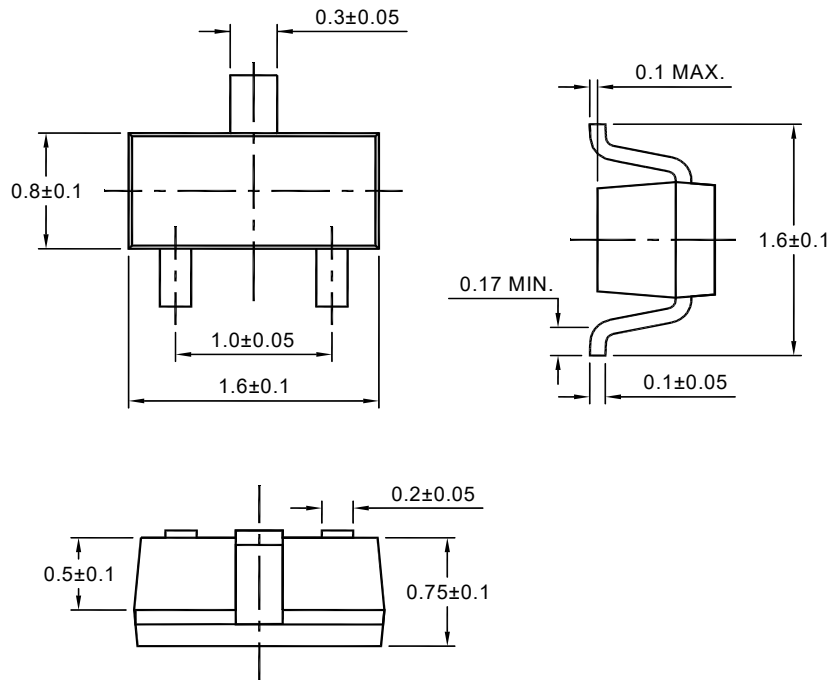

Recommended Soldering Footprint

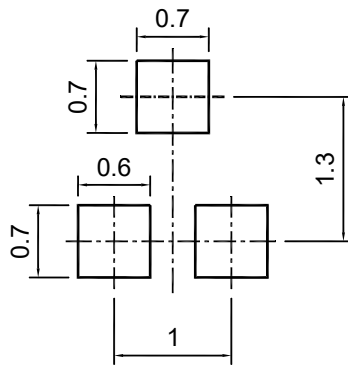

Packing information

Package	Tape Width (mm)	Pitch		Reel Size		Per Reel Packing Quantity
		mm	inch	mm	inch	
SOT-523	8	4 ± 0.1	0.157 ± 0.004	178	7	4,000

Marking information

" RN " = Part No.
 " YM " = Date Code Marking
 " Y " = Year
 " M " = Month
 Font type: Arial

