

28V, 2A, Forced PWM Synchronous Step-Down Converter in SOT23-6

DESCRIPTION

ETA8121 is a wide input range, high-efficiency and high frequency DC-to-DC step-down switching regulator, capable of delivering up to 2A of output current. With a fixed switching frequency of 1MHz, this current mode PWM controlled converter allows the use of small external components, such as ceramic input and output caps, as well as small inductors. ETA8121 also employs a forced PWM control scheme, thereby ensuring the minimum ripple voltage. Its input can withstand a voltage surge as high as 30V, making it an ideal solution for industrial applications such as Surveillance Camera, LCD TV, Set Top Box, etc. ETA8121 is available in SOT23-6 package.

FEATURES

- ◆ Wide Input Range: 4.2V-28V
- ◆ Forced PWM control
- ◆ 1MHz switching frequency
- ◆ Capable of Delivering 2A
- ◆ No External Compensation Needed
- ◆ Current Mode Control
- ◆ Thermal Shutdown and UVLO
- ◆ Excellent Load and Line Transient Response
- ◆ Available in SOT23-6 Package

APPLICATIONS

- ◆ Surveillance Camera
- ◆ Set Top Box
- ◆ LCD TV

TYPICAL APPLICATION

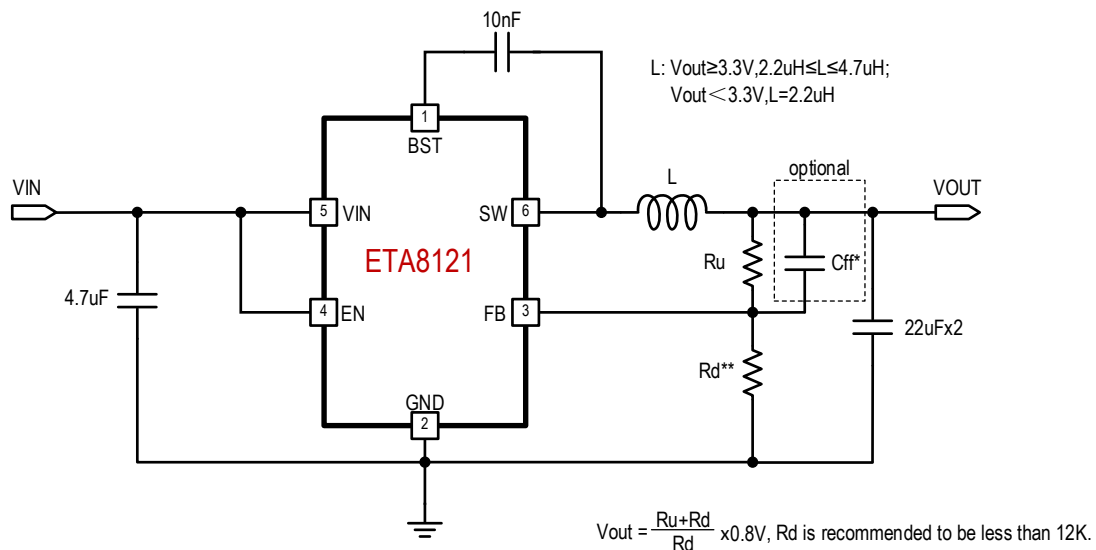

ORDERING

INFORMATION

PART No.	PACKAGE	TOP MARK	Pcs/Reel
ETA8121S2G	SOT23-6	CWYW	3000

PIN CONFIGURATION

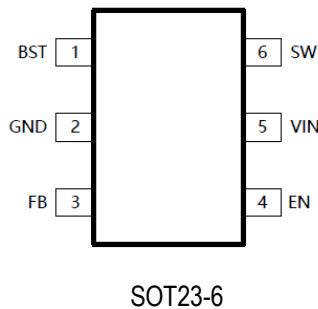

ABSOLUTE MAXIMUM RATINGS

(Note: Exceeding these limits may damage the device. Exposure to absolute maximum rating conditions for long periods may affect device reliability.)

IN, EN Voltage	-0.3V to 30V
SW Voltage	-0.3V (-5V <10nS) to 30V (<10nS)
BST Voltage	-0.3V to SW+6V
FB Voltage	-0.3V to 6V
Operating Temperature Range.....	-40°C to 85°C
Storage Temperature Range.....	-55°C to 150°C
Thermal Resistance	θ_{JA} θ_{JC}
SOT23-6.....	180.....90..... °C/W
Lead Temperature (Soldering 10sec)	260°C
ESD HBM (Human Body Mode)	2KV
ESD MM (Machine Mode)	200V

ELECTRICAL CHARACTERISTICS

($V_{IN} = 12V$, $V_{OUT} = 3.3V$, unless otherwise specified. Typical values are at $T_A = 25^\circ C$.)

PARAMETER	CONDITIONS	MIN	TYP	MAX	UNIT
Input Voltage Range		4.2		28	V
Input UVLO	Rising, Hysteresis=340mV		4.2		V
Input Supply Current	$V_{in}=12V$, $I_{out}=0$, $V_{fb}=0.85V$, no switching		750		μA
Input Shutdown Current			7	14	μA
FB Voltage		0.784	0.8	0.816	V
FB Input Current			0	1	μA
Switching Frequency			1000		kHz
Maximum Duty Cycle			99		%
Short Circuit Hiccup Time	On Time		2		mS
	Off Time		6		mS
FB Hiccup Threshold			0.2		V
High Side Switch On			160		m Ω
Low Side Switch On			95		m Ω
High Side Current Limit			3.5		A
SW Leakage Current	$I_{IN}=I_{SW}=12V$			20	μA
EN Rising Threshold		1.48	1.58	1.68	V
EN Falling Threshold		1.315	1.4	1.485	V
EN Input Current	$V_{EN}=2V$		1		μA
Thermal Shutdown	Rising, Hysteresis =40°C		150		°C

PIN DESCRIPTION

PIN #	NAME	DESCRIPTION
1	BST	Bootstrap pin. Connect a 10nF capacitor from this pin to SW
2	GND	Ground
3	FB	Feedback Input. Connect an external resistor divider from the output to FB and GND to set V_{OUT}
4	EN	Enable pin for the IC. Drive this pin high to enable the part, low to disable.
5	VIN	Supply Voltage. Bypass with a 4.7 μ F ceramic capacitor to GND
6	SW	Inductor Connection. Connect two 22 μ F capacitors from this pin to GND

TYPICAL CHARACTERISTICS

(Typical values are at $T_A = 25^\circ\text{C}$ unless otherwise specified.)

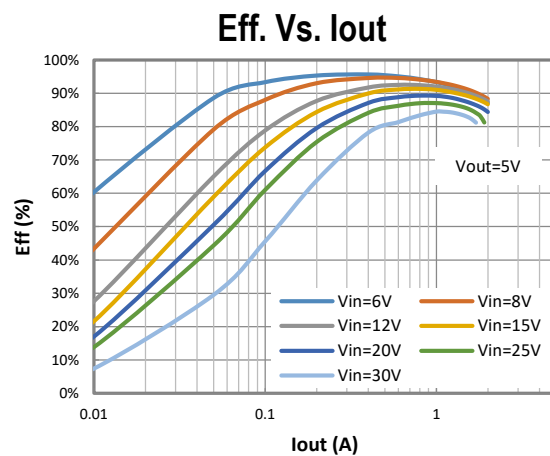
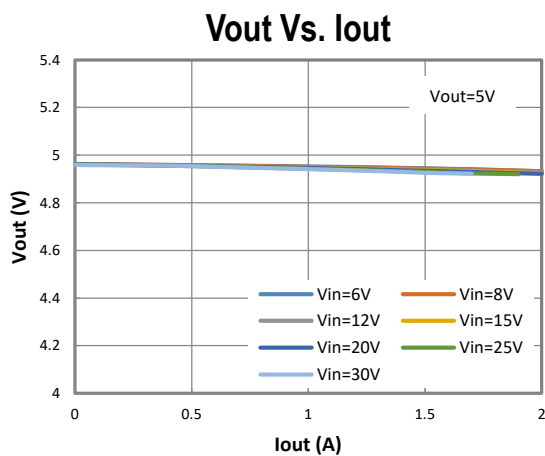
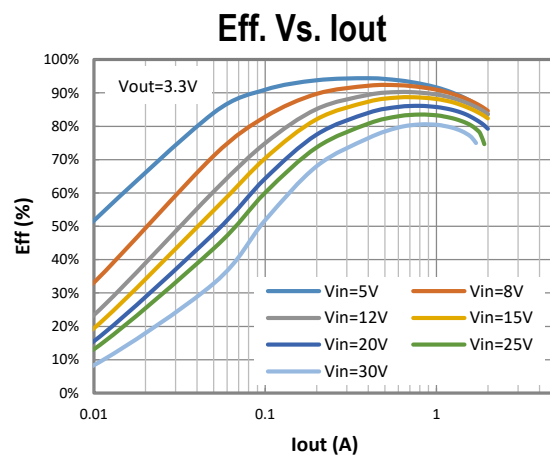
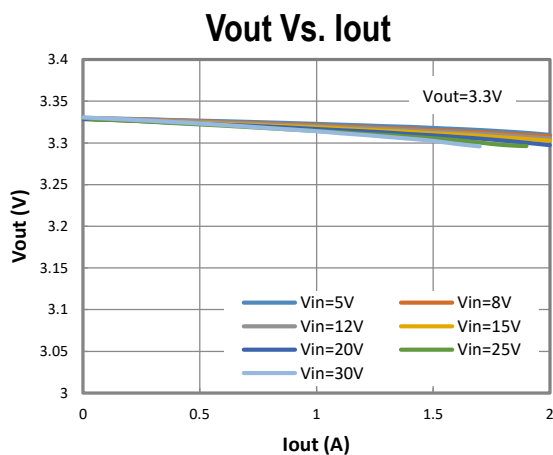

TYPICAL CHARACTERISTICS

(Typical values are at $T_A = 25^{\circ}\text{C}$ unless otherwise specified.)

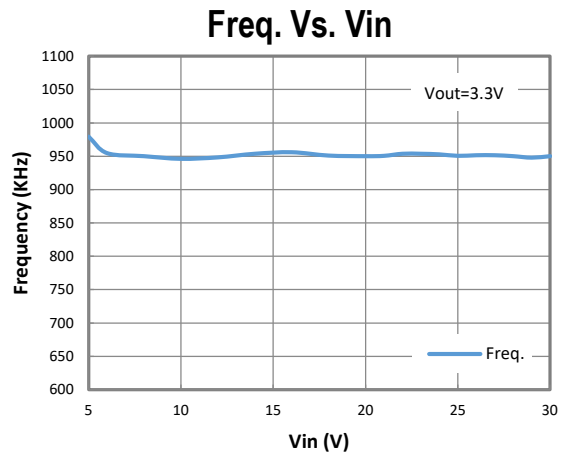
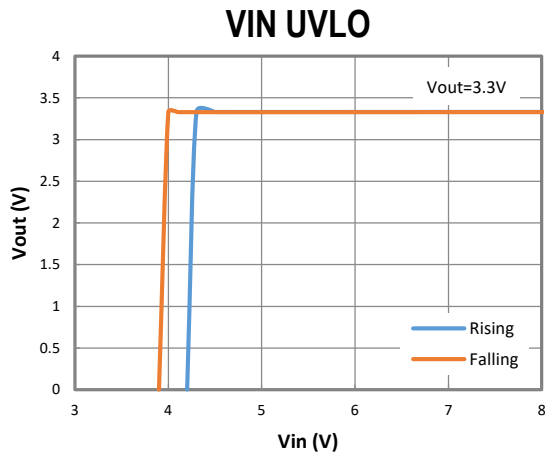

Switching Waveform at $I_{out} = 0\text{A}$
($V_{in} = 12\text{V}$, $V_{out} = 3.3\text{V}$)

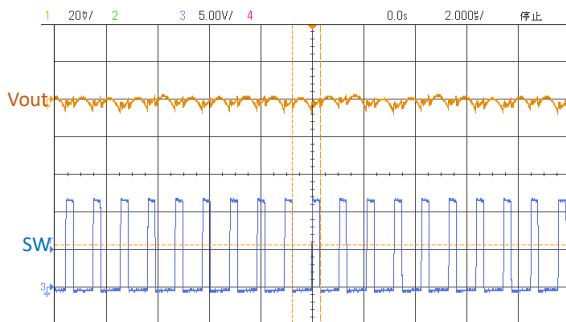

Switching Waveform at $I_{out} = 1\text{A}$
($V_{in} = 12\text{V}$, $V_{out} = 3.3\text{V}$)

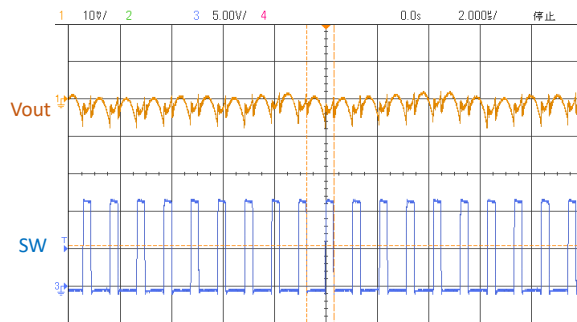

FUNCTIONAL BLOCK DIAGRAM

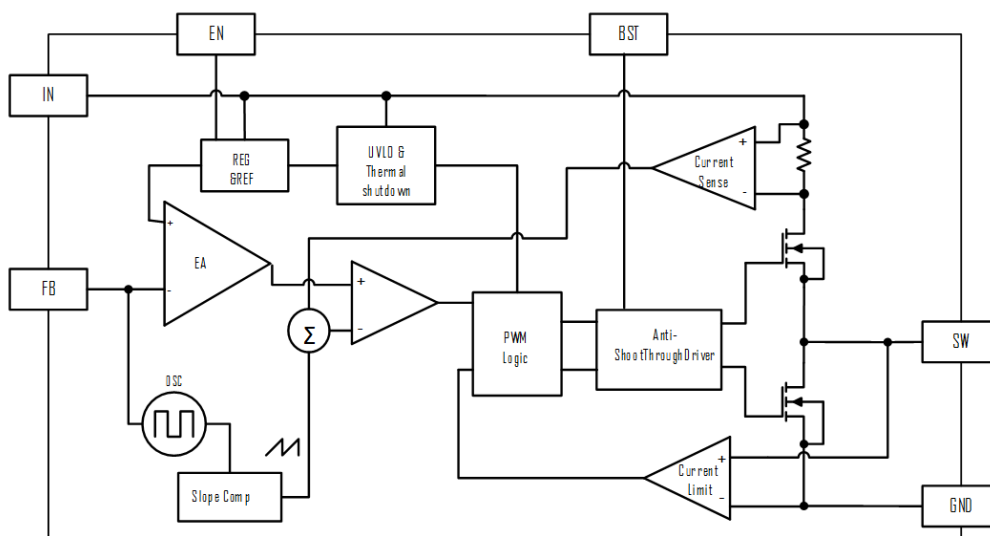

FUNCTIONAL DESCRIPTION

The ETA8121 is a synchronous buck regulator ICs that integrates the PWM control, top and bottom switches on the same die to minimize the switching transition loss and conduction loss.

The ETA8121 is a wide input range, high efficiency, DC-to-DC step-down switching regulator, capable of delivering up to 2A of output current, integrated with a 160mΩ high side and 95mΩ low side MOSFET. It uses PWM current-mode control scheme. An error amplifier integrates error between the FB signal and the internal reference voltage. The output of the integrator is then compared to the sum of a current-sense signal and the slope compensation ramp. This operation generates a PWM signal that modulates the duty cycle of the power MOSFET to achieve regulation for output voltage.

Forced PWM Operation

A forced PWM DC-DC regulator always switches at a fixed frequency even when the output load is small. This is to ensure a minimum output voltage ripple over the full load range. It may induce a relatively large (about 10mA when $V_{in}=12V$) input current when load is zero.

Enable

EN is a digital control pin that turns the ETA8121 on and off. Drive EN High to turn on the regulator, drive it Low to turn it off. An internal 1MΩ resistor from EN pin to GND allows EN to float to shutdown the chip. Connecting the EN pin through a pull up resistor or shorted EN to IN will automatically turn on the chip whenever plug in IN.

Over Current Protection and Hiccup

ETA8121 has a cycle-by-cycle over current limit for when the inductor current peak value is over the set current limit threshold. When the output voltage drop until FB falls below UV threshold (0.2V), the ETA8121 will enter hiccup mode. It will turn off the chip immediately for 6mS. After that, it will try to re-starts as normal for 2mS. After 2mS, if FB is still below UV threshold, then the chip enters hiccup mode again. If FB is higher than UV threshold, it will enter the normal mode.

Over-Temperature Protection

Thermal protection disables the output when the junction temperature rises to approximately 150°C, allowing the device to cool down. When the junction temperature cools to approximately 110°C, the output circuitry is again enabled. Depending on power dissipation, thermal resistance, and ambient temperature, the thermal protection circuit may cycle on and off. This cycling limits regulator dissipation, protecting the device from damage as a result of overheating.

APPLICATION INFORMATION

External Output Voltage Setting

In external Output Voltage Setting Version selected, the ETA8121 regulator is programmed using an external resistor divider. The output voltage is calculated using below equation.

$$V_{OUT} = V_{REF} \times \left(1 + \frac{R_u}{R_d}\right)$$

Where: VREF =0.8V typically (the internal reference voltage)

Resistors Rd has to be between 1kOhm to 12kOhm and thus Ru is calculated by following equation.

$$R_u = \left(\frac{V_{OUT}}{V_{REF}} - 1\right) \times R_d$$

PCB LAYOUT GUIDE

For any high voltage buck, it is always crucial to have input capacitor placed as close to the chip's IN and GND pin without any via, because the input capacitor is to keep the chip's real input voltage from dropping too much when large switching current is drawn from the input node. A simple illustration of how to place input capacitor and draw the trace to the chip's IN and GND pins is shown below, and it is highly recommended to strictly follow this guide.

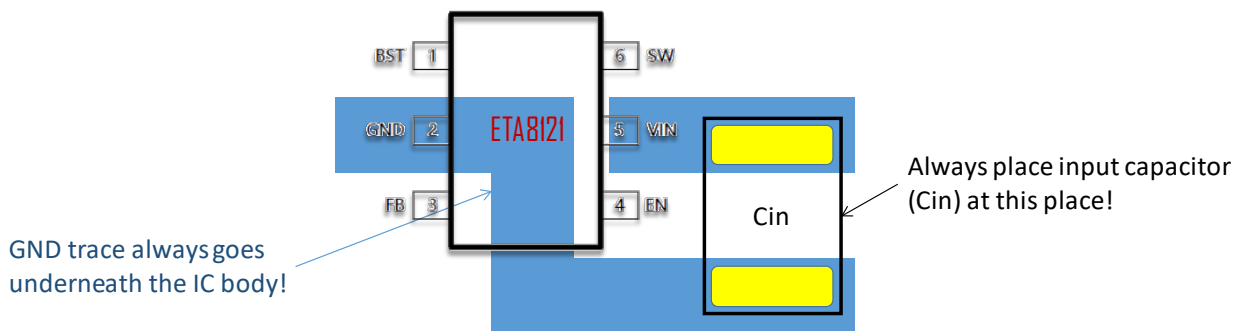

PACKAGE OUTLINE

Package: SOT23-6

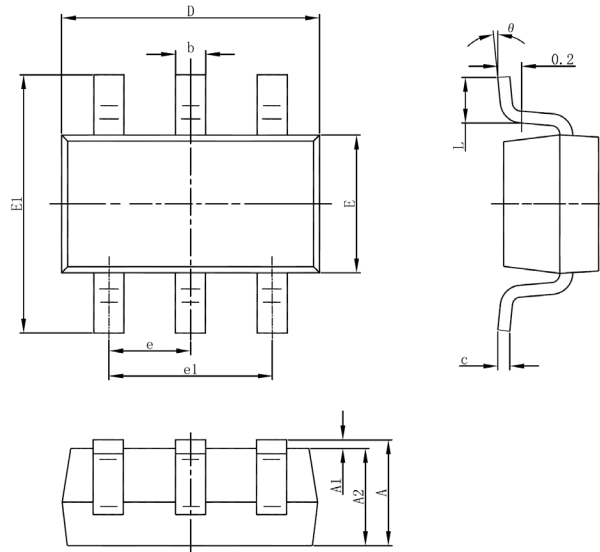

Symbol	Dimensions In Millimeters		Dimensions In Inches	
	Min	Max	Min	Max
A	1.050	1.250	0.041	0.049
A1	0.000	0.100	0.000	0.004
A2	1.050	1.150	0.041	0.045
b	0.300	0.500	0.012	0.020
c	0.100	0.200	0.004	0.008
D	2.820	3.020	0.111	0.119
E	1.500	1.700	0.059	0.067
E1	2.650	2.950	0.104	0.116
e	0.950(BSC)		0.037(BSC)	
e1	1.800	2.000	0.071	0.079
L	0.300	0.600	0.012	0.024
θ	0°	8°	0°	8°