

Description

The PSD15CL is designed to replace multilayer varistors (MLVs) in portable applications such as cell phones, notebook computers and PDA's, using monolithic silicon technology to provide fast response time and ultra low ESD clamping voltage, making this device an ideal solution for protecting sensitive semiconductor components from damage. The PSD15CL complies with the IEC 61000- 4-2 (ESD) standard with $\pm 15\text{kV}$ air and $\pm 15\text{kV}$ contact discharge. The PSD15CL is assembled into a lead-free SOD- 323 package and will protect one unidirectional line. These devices will fit on the same PCB pad area as an 0805 MLV device.

Features

- 150W peak pulse power (8/20us)
- Protects one data or power line
- Ultra low leakage: nA level
- Stand-off Voltage: 15 V
- Ultra low clamping voltage
- Complies with following standards:
 - IEC 61000-4-2 (ESD) immunity test
 - Air discharge: $> \pm 15\text{kV}$
 - Contact discharge: $> \pm 15\text{kV}$
- RoHS Compliant

Dimensions & Symbol (Unit: mm Max)

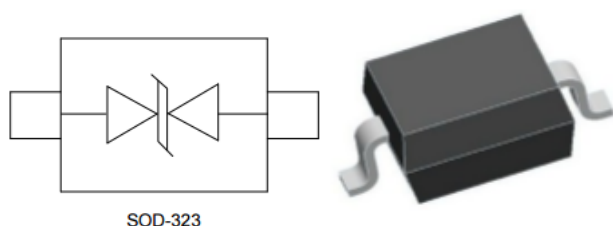

Mechanical Characteristics

- Package: SOD-323
- Lead Finish: Matte Tin
- Case Material: "Green" Molding Compound.
- Moisture Sensitivity: Level 3 per J-STD-020
- Terminal Connections: See Diagram Below
- Marking Information: See Below

Applications

- Cellular Handsets and Accessories
- Personal Digital Assistants
- Notebooks and Handhelds
- Portable Instrumentation
- Peripherals
- Pagers Peripherals
- Desktop and Servers
-

Marking information



Details marking code reference customer approval list

Ordering Information

Part Number	Packaging	Reel Size
PSD15CL	3000/Tape & Reel	7 inch

Absolute Maximum Ratings (T_A=25°C unless otherwise specified)

PARAMETER	SYMBOL	VALUE	UNITS
Peak Pulse Power (t _p = 8/20μs)	P _{PP}	150	Watts
Operating Temperature	T _J	-55°C to 125°C	°C
Storage Temperature	T _{STG}	-55°C to 150°C	°C

Electrical Characteristics (T_A = 25 °C unless otherwise noted)

PART NUMBER	V _{RWM}	V _B	I _T	V _{C@1A}	V _C		I _R	C _T
	(V) (max.)	(V) (min.)	(μA)	(V) (max.)	(V) (max.)	(@A)	(μA) (max.)	(pF) (max.)
PSD15CL	15.0	16.7	1	32.0	40.0	4	1	20

Typical Performance Characteristics (T_A=25°C unless otherwise Specified)

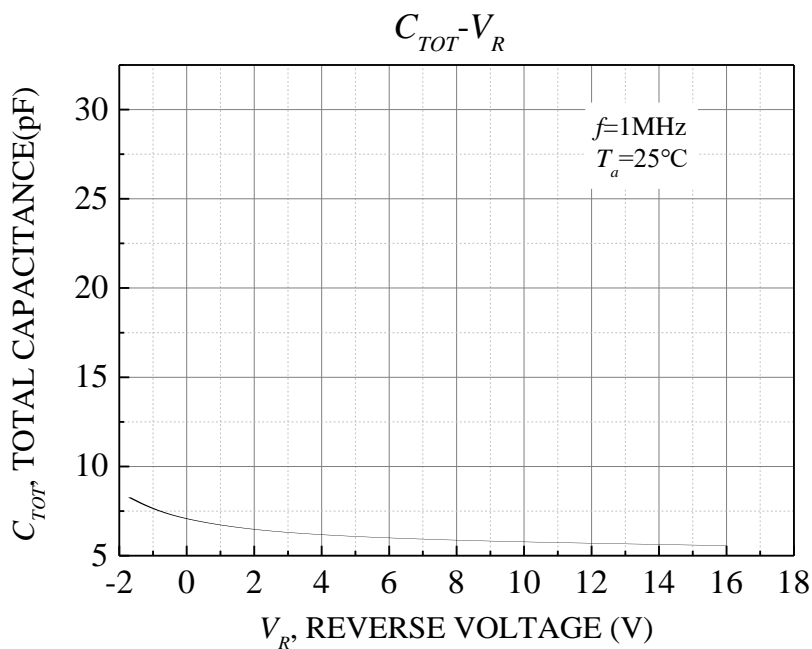
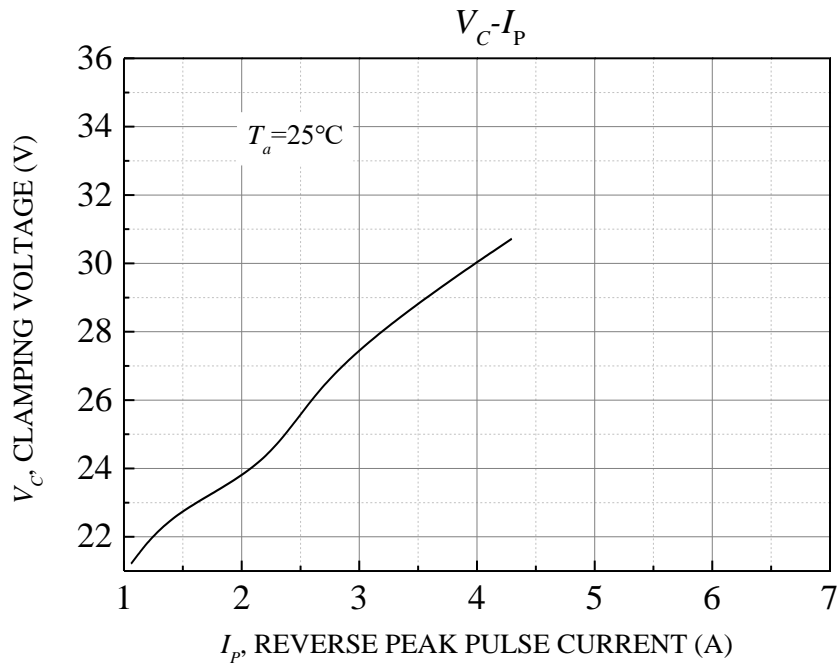

Soldering parameters

Reflow Condition		Pb-Free assembly (see FIG.2)
Pre Heat	-Temperature Min ($T_{s(min)}$)	+150 °C
	-Temperature Max($T_{s(max)}$)	+200 °C
	-Time (Min to Max) (ts)	60-180 secs.
Average ramp up rate (Liquid us Temp (T_L) to peak)		3 °C/sec. Max
$T_{s(max)}$ to T_L - Ramp-up Rate		3 °C/sec. Max
Reflow	-Temperature(T_L) (Liquid us)	+217 °C
	-Temperature(t_L)	60-150 secs.
Peak Temp (T_p)		+260(+0/-5) °C
Time within 5 °C of actual Peak Temp (t_p)		30 secs. Max
Ramp-down Rate		6 °C/sec. Max
Time 25 °C to Peak Temp (T_p)		8 min. Max
Do not exceed		+260 °C

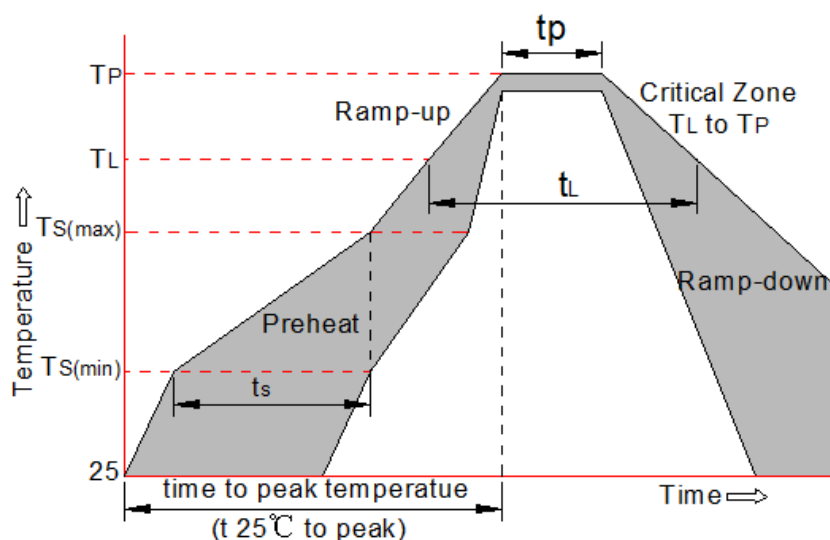

Package mechanical data (mm/inch)

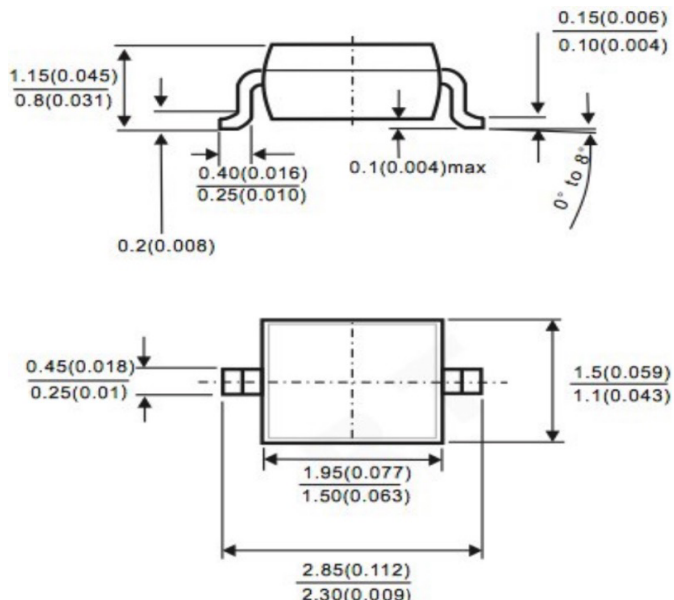

Suggested Land Pattern

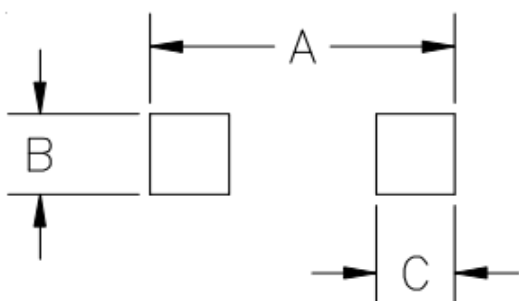

SYM	DIMENSIONS	
	MILLIMETERS	INCHES
A	3.15	0.120
B	0.80	0.031
C	0.80	0.031

Contact information

WPMTEK Incorporated Limited
 Room 206-207,2nd Floor,Block 3,Minxing Industry Park,Minzhi
 Longhua New District,Shenzhen
 TEL: 86755-29308003 FAX: 86755-23739900

WPMtek Incorporated Limited (WPM) reserves the right to make changes to the product specification and data in this document without notice. WPM makes no warranty, representation or guarantee regarding the suitability of its products for any particular purpose, nor does WPM assume any liability arising from the application or use of any products or circuits, and specifically dis- claims any and all liability, including without limitation special, consequential or incidental damages.