

To:

部品规格书

APPROVED FOR SHEET

系列 Series : LGA 105°C 10000H

规格 specifications: 250V56uF (10*25) ±20%

250V68uF (12.5*25) ±20%

承制方 Manufacturer	拟制 Prepared	校对 Checked	
	许文进	彭丽华	
使用方 Customer	审核 Checked	批准 Approved	客户确认 Customer Response

2023-05-25

样品明细表 Sample sheet

序号 NO	联晟物料号 LIAN SHENG (P/N)	系列 Series	规格/尺寸 Specification Size	容量偏差 Capacitance tolerance (%)	样品数量 (PCS) Amount	加工方式 Processing method
1	R00LGA2E560G025M00	LGA	250V56uF/10*25	-20~+20	20	长脚
2	R00LGA2E680W025M00	LGA	250V68uF/12.5*25	-20~+20	20	长脚
3						
4						
5						
6						
7						
8						
9						
10						
11						
12						
13						
14						
15						

品外形及尺寸 Appearance and size of parts

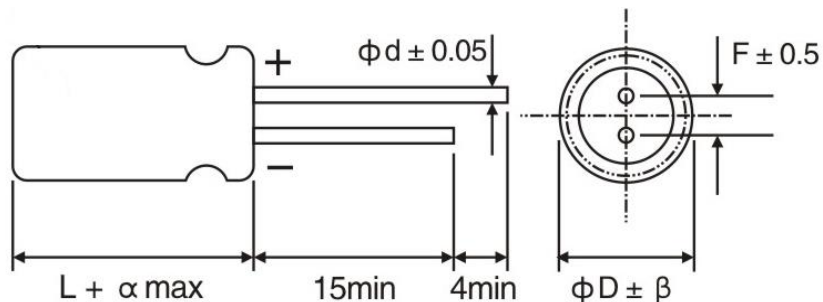

D	5	6	8	10	12.5	16	18	22	25
L	9	11	12	14	25	25	25	25	30
d	0.5			0.6		0.8			
F	2.0	2.5	3.5	5.0		7.5		10	12.8
α	± 2.0								
β	0~+0.5				0~+1.0				

技术要求 Technical Requirements

序列	部品描述 Part Description		技术标准									
	联晟物料号 LIAN SHENG (P/N)	系列 Series	额定电压 Rated voltage (V)	容量 capacity (uF)	损耗值 Dissipation Factor Max (%)	漏电流 Leakage Current (uA) 2min 充电时间	尺寸 Case size (mm)	容量组别 Capacitance Tolerance (%)	浪涌电压 Surge voltage (SV)	温度范围 Category Temperature Range (°C)	最大纹波电流 Ripple current 105°C (mA)	耐久性 Load life (105°C)
1	R00LGA2E560G025M00	LGA	250	56	15	290.0	10*25	-20~+20	300	-40~+105	100KHz --1068	10000H
2	R00LGA2E680W025M00	LGA	250	68	15	350.0	12.5*25	-20~+20	20	-40~+105	100KHz --1166	10000H
3												
4												
5												
6												
7												
8												
9												
10												
11												
12												
13												

1. 适用范围 Adapt Range

本部品承认书适用于江西联晟电子有限公司铝电解电容器产品。质量标准按照 IEC-60384.特性要求。

This product specification applies to polar Aluminum electrolytic capacitor (foil type) used in electronic equipment. of JIANGXI LIANSHENG ELECTRONIC CO., LTD.

Designed capacitor's quality meets IEC60384.

ROHS 指令(2002/95/EC)已对应完毕。

Completely compliant with ROHS (2002/95/EC)。

2. 部品标识 Product Marking

电容器上应清楚地标出(Marking Details Capacitor shall be marked the following items):

- 1、标称电容量(Nominal capacitance): μF
- 2、额定电压(Rated voltage): **V**
- 3、引出端极性(阴极极性带)(Polarity): Cathode shall be marked with a black stripe and indicate "-" symbol on it.
- 4、系列代号(Series symbol): **LGA**
- 5、制造厂商标(Trademark): **LSTL**
- 6、最高使用温度(Maximum operating temperature):**105°C**
- 7、年度标志 (Annual mark)

年度标志字母代号

年度	字母	年度	字母	年度	字母	年度	字母
2010	A	2015	F	2020	M	2025	T
2011	B	2016	H	2021	N	2026	U
2012	C	2017	J	2022	P	2027	V
2013	D	2018	K	2023	R	2028	W
2014	E	2019	L	2024	S	2029	X

备注：年度字母代号每 20 年为一个循环使用期，如 2016 年度字母代号为 H,以此类推。

8、标示图样 (Marking Sample)

8.1 规格版

商 标 Manufacturer: trademark 

额定电压/标称电容量 Rated voltage/ Nominal capacitance  250V56 μF

负极标志 Cathode indicate 

8.2 日期版

产品型号 Products series  LGA

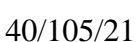
气候类别 Maximum operating temperature  40/105/21

年度代码 Production annual code  R

8.3 套管颜色：咖啡色金字

3、特性表 (Characteristics)

寿命 Load life: 105°C, 10000h

符合 RoHS 标准。Complied to the RoHS directive.

项 目 Items	特 性 Characteristics																								
工作温度范围 Operating temperature range	-40~+105°C																								
额定工作电压范围 Rated working voltage range	160V~500V																								
静电容量允许偏差 Capacitance tolerance	-20%~+20% (V) (20°C, 120Hz)																								
损耗角正切值 Dissipation Factor (MAX)	<p>当容量大于 1000 μF 时, 容量每增加 1000 μF, tg δ 增加 0.02。 Capacitance > 1000 μF : tg δ increases by 0.02 for each 1000 μF from below value. 20°C, 120Hz</p> <table border="1"> <tr> <td>U_R(V)</td> <td>160</td> <td>200</td> <td>250</td> <td>300~350</td> <td>400</td> <td>450</td> <td>500</td> </tr> <tr> <td>tg δ</td> <td>0.15</td> <td>0.15</td> <td>0.15</td> <td>0.20</td> <td>0.20</td> <td>0.20</td> <td>0.24</td> </tr> </table>	U _R (V)	160	200	250	300~350	400	450	500	tg δ	0.15	0.15	0.15	0.20	0.20	0.20	0.24								
U _R (V)	160	200	250	300~350	400	450	500																		
tg δ	0.15	0.15	0.15	0.20	0.20	0.20	0.24																		
阻抗比 (120Hz) Impedance ratio (MAX)	<p style="text-align: right;">120Hz</p> <table border="1"> <tr> <td>U_R(V)</td> <td>160</td> <td>200</td> <td>250</td> <td>350</td> <td>400</td> <td>450</td> <td>500</td> </tr> <tr> <td>Z-25°C/+20°C</td> <td>3</td> <td>3</td> <td>3</td> <td>5</td> <td>5</td> <td>6</td> <td>6</td> </tr> <tr> <td>Z-40°C/+20°C</td> <td>6</td> <td>6</td> <td>6</td> <td>6</td> <td>6</td> <td>--</td> <td>--</td> </tr> </table>	U _R (V)	160	200	250	350	400	450	500	Z-25°C/+20°C	3	3	3	5	5	6	6	Z-40°C/+20°C	6	6	6	6	6	--	--
U _R (V)	160	200	250	350	400	450	500																		
Z-25°C/+20°C	3	3	3	5	5	6	6																		
Z-40°C/+20°C	6	6	6	6	6	--	--																		
漏电流 Leakage current (MAX)	<p>160~400V: I=0.02C_RU_R+10 (20°C, 施加额定电压 2 分钟) 450~500V: I=0.03C_RU_R+10 (20°C, 施加额定电压 2 分钟) 160~400V: I=0.02C_RU_R+10 (at 20°C, After 2 minutes application of rated voltage) 450~500V: I=0.03C_RU_R+10, (at 20°C, After 2 minutes application of rated voltage) I=漏电流 (μA) U_R=额定电压 (V) C_R=静电容量 (μF) Leakage Current Rated Voltage Rated Capacitance</p>																								
耐久性 (105°C) Load life	<p>105°C 施加带额定纹波电流的额定电压 10000 小时, 恢复 24 小时后: After applying rated voltage with specified ripple for 10000 hours at 105°C and then resumed 24 hours</p> <table border="1"> <tr> <td>漏电流 Leakage current</td> <td>≤规定值 ≤specified value</td> </tr> <tr> <td>损耗角正切值 tg δ</td> <td>≤规定值的 200% ≤200% of specified value</td> </tr> <tr> <td>静电容量变化率: capacitance change</td> <td>初始值±20%以内 Within ±20% of initial value</td> </tr> </table>	漏电流 Leakage current	≤规定值 ≤specified value	损耗角正切值 tg δ	≤规定值的 200% ≤200% of specified value	静电容量变化率: capacitance change	初始值±20%以内 Within ±20% of initial value																		
漏电流 Leakage current	≤规定值 ≤specified value																								
损耗角正切值 tg δ	≤规定值的 200% ≤200% of specified value																								
静电容量变化率: capacitance change	初始值±20%以内 Within ±20% of initial value																								
高温贮存(105°C) Shelf life	<p>105°C 搁置 1000h, 试验后, 在 20°C±5°C 下, 按 JIS C 5101-4 第 4.1 进行预处理后, 测试, 其电性能符合: The following specifications shall be satisfied when the capacitors performing voltage treatment based on JIS C 5101-4 clause 4.1 at 20°C after exposing them for 1000hours at 105°C without voltage applied.</p> <table border="1"> <tr> <td>漏电流 Leakage current</td> <td>≤规定值的 200% ≤200% of specified value</td> </tr> <tr> <td>损耗角正切值 tg δ</td> <td>≤规定值的 200% ≤200% of specified value</td> </tr> <tr> <td>静电容量变化率: capacitance change</td> <td>初始值±20%以内 Within ±20% of initial value</td> </tr> </table>	漏电流 Leakage current	≤规定值的 200% ≤200% of specified value	损耗角正切值 tg δ	≤规定值的 200% ≤200% of specified value	静电容量变化率: capacitance change	初始值±20%以内 Within ±20% of initial value																		
漏电流 Leakage current	≤规定值的 200% ≤200% of specified value																								
损耗角正切值 tg δ	≤规定值的 200% ≤200% of specified value																								
静电容量变化率: capacitance change	初始值±20%以内 Within ±20% of initial value																								

4. 电气特性 electrical characteristics:

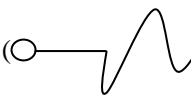
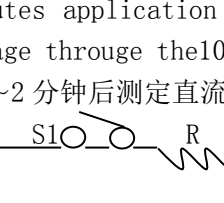
NO.	ITEM 项目	TEST METHOD 测试方法	SPECIFICATION 规格																		
4.1	Rated voltage 额定电压		Voltages range, capacitance range, see specification of this series 电压, 电容, 范围请看该系列之规格说明																		
4.2	Capacitance 静电电容	1. Measuring frequency: 120HZ ± 12HZ 测定频率																			
4.3	Dissipation Factor 散逸因素 (损失角)	2. Measuring voltage: $\leq 0.5V_{rms} + 0.5VDC \sim 2.0VDC$ 测定电压 3. Measuring circuit: 																			
4.4	Leakage Current (泄漏电流)	<p>Dc leakage current shall be measured after 1 ~ 2 minutes application of the Dc rated working voltage through the 1000 Ω 的电阻施加直流工作电压 1~2 分钟后测定直流泄漏电流</p>  <p>R: 1000 Ω S1: Switch 开关 A: Dc current 直流电流计 S2: switch for protection of current meter 直流电流计的保护开关 V: DC Voltage meter 直流电压计 Cx: testing capacitor 测试电容</p>	Dissipation factor, leakage current, see specification of this series. 损失角、泄漏电流前看该系列之规格说明。																		
4.5	Temperature characteristics 温度特性	<table border="1"> <thead> <tr> <th>STEP TIME</th> <th>TEMPERATURE</th> <th>STORAGE</th> </tr> <tr> <th>步骤</th> <th>温度</th> <th>放置时间</th> </tr> </thead> <tbody> <tr> <td>1</td> <td>20°C ± 2°C</td> <td>30minutes</td> </tr> <tr> <td>2</td> <td>10°C ± 3°C、-25°C ± 3°C</td> <td>2hours</td> </tr> <tr> <td>3</td> <td>20°C ± 2°C</td> <td>15minutes</td> </tr> <tr> <td>4</td> <td>105°C ± 2°C</td> <td>2hours</td> </tr> </tbody> </table> <p>Step1. Measure the capacitance and impedance 测定静电容量及阻抗 (Z , 20°C, 120HZ ± 10%) Step2. Measure the impedance at thermal after 2 hours 达到热平衡 2 小时后测定阻抗。 (Z , -40°C, -25°C、120HZ ± 10%) Step4. Measure the capacitance at thermal balance after 2 hours 达到热平衡 2 小时后测定静电容量。</p>	STEP TIME	TEMPERATURE	STORAGE	步骤	温度	放置时间	1	20°C ± 2°C	30minutes	2	10°C ± 3°C、-25°C ± 3°C	2hours	3	20°C ± 2°C	15minutes	4	105°C ± 2°C	2hours	<p>Step2. Low temperature Impedance stability Less than specified value 低温稳定阻抗比: 低于规定值</p> <p>Step4. Capacitance change: with ± 20% of the initial measured value 静电容量变化: 最初测定值的 ± 20% 以内</p> <p>Dissipation Factor Less than specified value 损失角: 低于规定值</p>
STEP TIME	TEMPERATURE	STORAGE																			
步骤	温度	放置时间																			
1	20°C ± 2°C	30minutes																			
2	10°C ± 3°C、-25°C ± 3°C	2hours																			
3	20°C ± 2°C	15minutes																			
4	105°C ± 2°C	2hours																			

NO.	ITEM 项目	TEST METHOD 测试方法	SPECIFICATION 规格
4.6	Surge test 突破实验	<p>Rated surge voltage shall be applied (switch on) For 30±5 second and then shall be applied (switch off) discharge for 5±0.5 min at room Temperature. this cycle shall be repeated For 1000 cycles.ration of one cycle is 6±0.5 minutes</p> <p>在常温下施加（合上开关）额定涌浪电压 30±5 秒，然后停止施加（断开开关）涌浪电压并且放电 5±0.5 分钟，这个循环要重复 1000 次。以 6±0.5 分钟为一个循环周期。</p>	<p>Capacitance change : with±20% of the initial specified value 静电容量变化：最初测定值的±20% 以内。</p> <p>Dissipation factor: Less than 200% of zhe initial specified value. 损失角：低于最初规定值 200%。</p> <p>Leakage current: With initial specified value 泄漏电流：低于规定值</p>

5. 机械特性 mechanical characteristics :

NO.	ITEM 项目	TEST METHOD 测试方法	SPECIFICATION 规格																										
5.1	Lead Strength 端子强度	<p>(A) Tensile strength 拉伸强度: Wire lead terminal 导针型:</p> <table border="1"> <tr> <td>d(mm)</td> <td>≤0.45</td> <td>0.5~0.8</td> <td>0.8~d≤1.25</td> </tr> <tr> <td>Load(kg)</td> <td>0.5</td> <td>1.0</td> <td>2.0</td> </tr> </table> <p>Snap-in terminal 牛角型:</p> <table border="1"> <tr> <td>d(mm)</td> <td>Snap-in terminal 牛角端子</td> </tr> <tr> <td>Load(kg)</td> <td>2.0</td> </tr> </table> <p>The capacitor shall withstand the constant tensile force specified between the body and cache lead for 10 seconde without damage either inechanical or electrical 电容器各端子要承受规定的荷重 10 秒，不能有电气或机械特性上的损伤</p> <p>(B) bending strength 弯曲强度: Wire lead terminal 导针型:</p> <table border="1"> <tr> <td>d(mm)</td> <td>≤0.45</td> <td>0.5~0.8</td> <td>0.8∠d≤1.25</td> </tr> <tr> <td>Load(kg)</td> <td>0.25</td> <td>0.5</td> <td>1.0</td> </tr> </table> <p>Snap-in terminal 牛角型:</p> <table border="1"> <tr> <td>Cross section area of terminal 端子截面积 (m m²)</td> <td>Force 拉伸力 (kg)</td> </tr> <tr> <td>0.5∠S≤1</td> <td>1.0</td> </tr> <tr> <td>S > 1</td> <td>2.5</td> </tr> </table> <p>With the capacitor in a vertical position apply the load specified axially to each lead.the capacitor shall be rotated slowly from the vertical to the horizontal position.back to the vertical position.the 90in zhe opposite direction and back the original position.preformance of capacitor shall not have change and leads shall be undamaged . 给在竖直位置的电容器每一端子以轴心方向施加规定荷重，慢慢将电容器由竖直位置转至水平位置，然后向相反方向弯曲 90 度，再回到原来的位置。电容器性能不能有变化及端子不能有损伤。</p>	d(mm)	≤0.45	0.5~0.8	0.8~d≤1.25	Load(kg)	0.5	1.0	2.0	d(mm)	Snap-in terminal 牛角端子	Load(kg)	2.0	d(mm)	≤0.45	0.5~0.8	0.8∠d≤1.25	Load(kg)	0.25	0.5	1.0	Cross section area of terminal 端子截面积 (m m²)	Force 拉伸力 (kg)	0.5∠S≤1	1.0	S > 1	2.5	<p>When the capacitance ismeasured,there shall be on intermittent contacts,oropen-or short-circuiting. 测定静电容量时，不能有接触不良、开路或短路</p> <p>There shall be on such mechanical damage as terminal damage as terminal damage etc. 不能有如端子受损之类的机械特性上的损伤</p>
d(mm)	≤0.45	0.5~0.8	0.8~d≤1.25																										
Load(kg)	0.5	1.0	2.0																										
d(mm)	Snap-in terminal 牛角端子																												
Load(kg)	2.0																												
d(mm)	≤0.45	0.5~0.8	0.8∠d≤1.25																										
Load(kg)	0.25	0.5	1.0																										
Cross section area of terminal 端子截面积 (m m²)	Force 拉伸力 (kg)																												
0.5∠S≤1	1.0																												
S > 1	2.5																												

NO.	ITEM 项目	TEST METHOD 测试方法	SPECIFICATION 规格
5.2	Vibration resistance 耐振性	<p>The frequency of the vibration shall vary uniformly within the range 10 to 55 HZ with the amplitude of 1.5mm, completing the cycle in the interval of one minute.</p> <p>The capacitor shall be securely mounted by its leads with hold the body of capacitor.</p> <p>The capacitor shall be vibrated in three mutually perpendicular directions for a period of 2 hours in each direction.</p> <p>振动频率要均匀, 范围为 10HZ 到 55HZ, 振幅为 1.5mm, 在一分钟内完成该循环。</p> <p>电容器将端子牢固的固定。</p> <p>电容器会被向三个互相垂直的方向每个方向振动 2 小时。</p>	<p>Capacitance: no unsteady 静电容量, 要稳定</p> <p>Appearance: no abnormal 外观, 无异常</p> <p>Capacitance change: Within $\pm 5\%$ of initial measured value. 容量变化: 最初测定值的 $\pm 5\%$ 之内。</p>
5.3	Solder ability 焊锡性	<p>The leads are dipped in the solder bath of snip at $260^{\circ}\text{C} \pm 5^{\circ}\text{C}$ for 2 ± 0.5 seconds. the dipping should be set at 1.5~2.0mm.</p>	<p>The solder alloy shall cover the 95% or more of dipped lead sari. 锡液要覆盖导针侵入表面积 95% 以上。</p>

6. 信耐度 Reliability:

NO.	ITEM 项目	TEST METHOD 测试方法	SPECIFICATION 规格
6.1	Soldering heat resistance 焊锡耐热性	<p>The leads immerse in the solder bath snip at $260^{\circ}\text{C} \pm 5^{\circ}\text{C}$ for 10 ± 1 seconds until a distance of 1.5mm. from the case.</p> <p>导针在 $260^{\circ}\text{C} \pm 5^{\circ}\text{C}$ 的锡/铅焊液中浸没至离本体 1.5 mm 的地方 10 ± 1 秒钟。</p>	<p>No visible damage or leakage of electrolyte . 无明显的的损伤或电解液漏出。</p> <p>Capacitance change: Within $\pm 5\%$ of initial measured value. 容量变化: 最初测定值的 $\pm 5\%$ 之内。</p> <p>Tan S: Less than specified value 损失角: 低于规定值</p> <p>Leakage current: Less than specified value 泄漏电流: 低于规定值</p>
6.2	Damp head (steady state) 耐湿性 (稳定状态)	<p>Subject the capacitor to $40^{\circ}\text{C} \pm 2^{\circ}$ and 90% to 95% relative humidity for 240 ± 8 hours.</p> <p>电容器在 $40^{\circ}\text{C} \pm 2^{\circ}$ 及相对湿度 90% 到 95% 的条件下经历 240 ± 8 小时。</p>	<p>Capacitance change Within $\pm 20\%$ of initial measured value. 容量变化: 最初测定值的 $\pm 5\%$ 之内。</p> <p>Tan S: Less than specified value 损失角: 低于规定值</p> <p>Leakage current: Less than specified value 泄漏电流: 低于规定值</p>

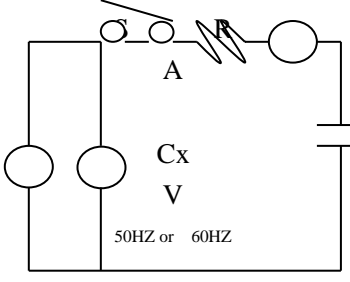
NO.	ITEM 项目	TEST METHOD 测试方法	SPECIFICATION 规格														
6.3	Load life 高温负荷	After 10000 hours continuous application of DC ratted working voltage at 105°C, the measurements shall meet the following temperature. 在 105°C 环境当中连续施加直流定格电压 10000 小时后, 按以下条件测试: 测试在室温放置 24 小时后进行, 施加直流定格电压 2 分钟后进行。															
6.4	Shelf life 高温贮存	After steerage for 1000 hours at 105°C with voltage application, the measurements shall meet the following limits. measurements shall be performed after esposed for 24 hours at room temperature after application of DC rated voltage to the capacitor for 2 minutes. 在 105°C 环境当中不施加直流定格 1000 个小时后, 按以下条件测试: 测试室温放置 24 小时, 施加直流定格电压 2 分钟后进行。	Standard of judgment is according to this series requirement . 判定标准依该系列要求。														
6.5	Storage at low temperature 低温贮存	The capacitor shall be stored at temperature of -25°C ±3°C for 96±4 hours. During which time be subjected to standard atmospherics conditions for 16 hours of more. After which measurements shall be made. 电容器在 -25°C ±3°C 环境当中贮存 96±4 小时, 其间不施加电压。之后, 在标准大气压中放置 16 小时以上, 然后进行测试。	Capacitance change: Within ±20% of initial measured value. 容量变化: 最初测定值的 ±20% 之内。 Less than specified value 损失角: 低于规定值 Leakage current: Less than specified value 泄漏电流: 低于规定值 Appearance: no abnormal 外观, 无异常														
6.6	Pressure relief 防爆试验	AC test 试验: Applied voltage: AC voltage not exceeding 0.7 times of this rated direct voltage or 250V AC whichever is the lower. 施加电压: 不超过定格电压 0.7 倍的交流电压或低于交流电压 250V 的任意电压。 Frequency 频率: 50 HZ or 60 HZ Series resistor: refer to the table below 串联阻抗: 参照下表 <table border="1" data-bbox="427 1682 1070 1984"> <thead> <tr> <th>Capacitance(C) 容量</th> <th>Series resistor</th> </tr> </thead> <tbody> <tr> <td>C < 1UF</td> <td>1000</td> </tr> <tr> <td>1UF < C ≤ 10UF</td> <td>100</td> </tr> <tr> <td>10UF < C ≤ 100UF</td> <td>10</td> </tr> <tr> <td>100UF < C ≤ 1000UF</td> <td>1</td> </tr> <tr> <td>1000UF < C ≤ 10000UF</td> <td>0.1</td> </tr> <tr> <td>10000UF < C</td> <td>*</td> </tr> </tbody> </table> Resistance is equivalent to a half impedance by test frequency 相当于试验频率的一半阻抗值	Capacitance(C) 容量	Series resistor	C < 1UF	1000	1UF < C ≤ 10UF	100	10UF < C ≤ 100UF	10	100UF < C ≤ 1000UF	1	1000UF < C ≤ 10000UF	0.1	10000UF < C	*	AC test circuit 交流试验回路  ○ : Acpower 交流电源 S: switch 开关 ○ : AC voltage meter 交流电压计 ○ : AC voltage meter 交流电压计 R: protection resistor 保护电阻 Cx: testing capacitor 供试电容器
Capacitance(C) 容量	Series resistor																
C < 1UF	1000																
1UF < C ≤ 10UF	100																
10UF < C ≤ 100UF	10																
100UF < C ≤ 1000UF	1																
1000UF < C ≤ 10000UF	0.1																
10000UF < C	*																

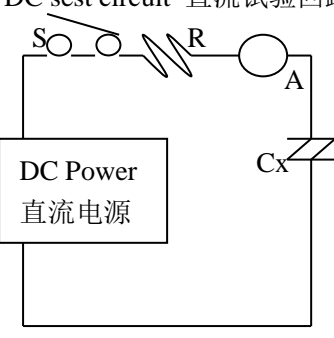
NO.	ITEM 项目	TEST METHOD 测试方法	SPECIFICATION 规格																																										
6.6	Pressure relief 防爆试验	<p>DC test 直流测试</p> <p>Send the following electircity while applying the inverse voltage .施加反向电压时通入下记电流:</p> <p>Where case size 外壳尺寸 (D 直径)</p> <p style="text-align: center;">D ≤ 22.4mm: 1A D. C. max D > 22.4mm: 16A D. C. max</p> <p>Note: 1. this requirement applies to capacitors with a diameter fr 6mm or more. 2. when the preesure relief divide does not open even 30 minutes after commencement of test. the test may be ended.</p> <p>注: 1. 此要求对于直径 6 mm 或以上之电容适用。 2. 试验开始, 经 30 分钟后防爆标志仍不动作, 试验终止。</p>	<p>DC sest circuit 直流试验回路</p>  <p>S: Switch 开关 DC current meter 直流电流计 Cx: test capacitor 供试电容器</p> <p>The pressure relief divide shall open in such a way as to capacitor elements (terminal and foil eat) or cover. 防爆标志必须动作, 以防止发生为灾爆炸或金属片飞溅。</p>																																										
6.7	Rated voltage and surge voltage 额定电压和实破电压	<table border="1" style="width: 100%; text-align: center;"> <tr> <td>RV (V)</td> <td>6.3</td> <td>10</td> <td>16</td> <td>25</td> <td>35</td> <td>50</td> </tr> <tr> <td>S.V (V)</td> <td>8</td> <td>13</td> <td>20</td> <td>32</td> <td>44</td> <td>63</td> </tr> <tr> <td>RV (V)</td> <td>63</td> <td>80</td> <td>100</td> <td>160</td> <td>200</td> <td>250</td> </tr> <tr> <td>S.V (V)</td> <td>79</td> <td>100</td> <td>125</td> <td>200</td> <td>250</td> <td>300</td> </tr> <tr> <td>RV (V)</td> <td>350</td> <td>400</td> <td>450</td> <td>500</td> <td></td> <td></td> </tr> <tr> <td>S.V (V)</td> <td>400</td> <td>450</td> <td>500</td> <td>550</td> <td></td> <td></td> </tr> </table>	RV (V)	6.3	10	16	25	35	50	S.V (V)	8	13	20	32	44	63	RV (V)	63	80	100	160	200	250	S.V (V)	79	100	125	200	250	300	RV (V)	350	400	450	500			S.V (V)	400	450	500	550			
RV (V)	6.3	10	16	25	35	50																																							
S.V (V)	8	13	20	32	44	63																																							
RV (V)	63	80	100	160	200	250																																							
S.V (V)	79	100	125	200	250	300																																							
RV (V)	350	400	450	500																																									
S.V (V)	400	450	500	550																																									

7. 材料构成表 Material composition table :

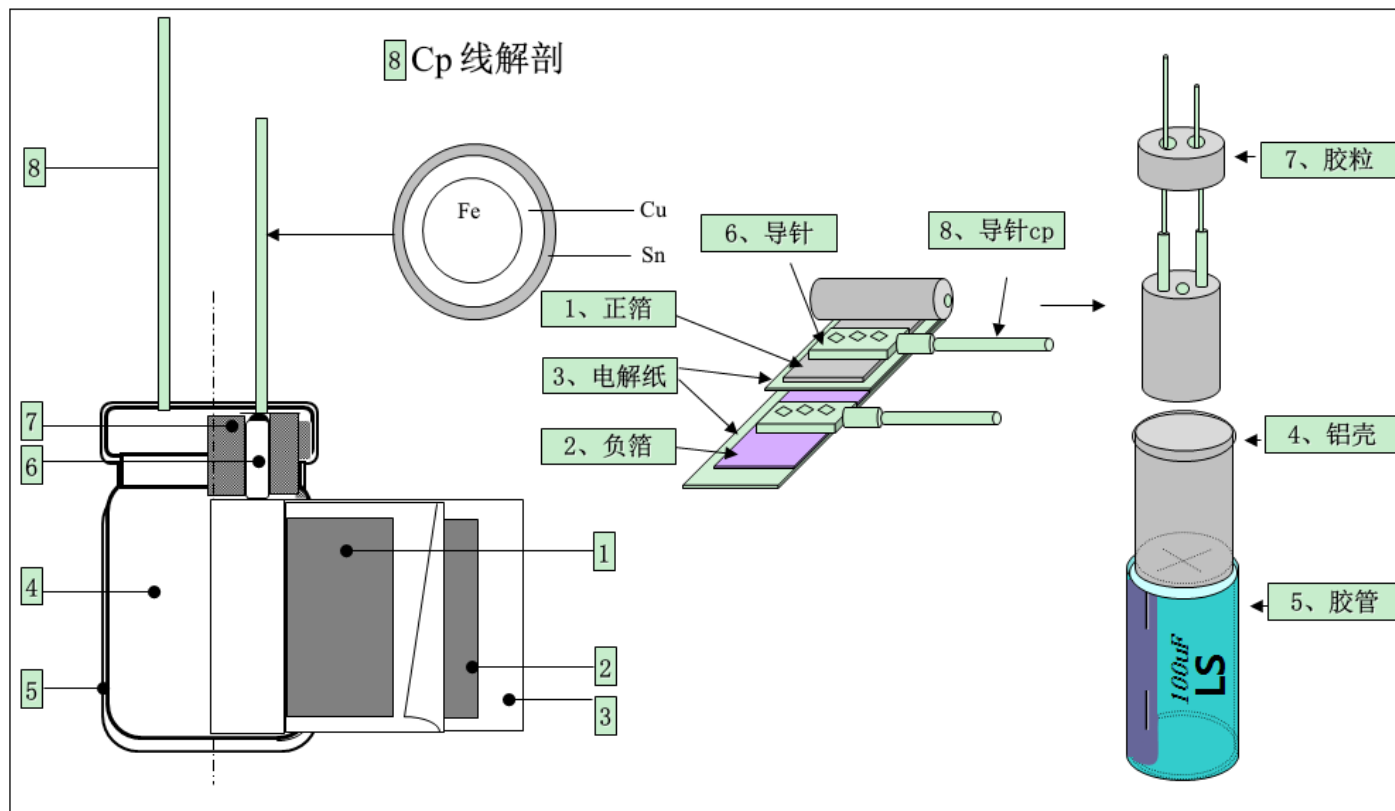

7.1 材料成分表

序号 NO	部件名称 Parts	材料名称 Material	主要供货商 Main supplier	
1	阳极箔 AL-foil(+)	铝 Aluminum	低压	宏远 HongYuan 海星 Haixin
			高压	海星 Haixing
2	阴极箔 AL-foil(-)	铝 Aluminum	飞乐 Feile	
3	电解纸 Separator paper	木材纸浆、棉浆纸 paper pulp	凯恩 Kaien	
4	铝壳 AL-case	99.5%纯度铝 99.5% Al	安琪利/奥新 Anqili/Aoxin	
5	胶管 Sleeve	PET (Poly vinyl chloride)	云林 Yunling	
6	导针 Guide pin	铝+CP 线 Aluminum+CP wire	新盛 xingsheng	
7	胶粒 Colloidal particles	合成橡胶 IIR Synthetic rubber	联华鑫 Lianhuaxin	
8	电解液 Electrolyte	乙二醇+有机酸盐 Glycol+organic acid salt	浩泰 Haotai	

铝电解电容器生产工程图

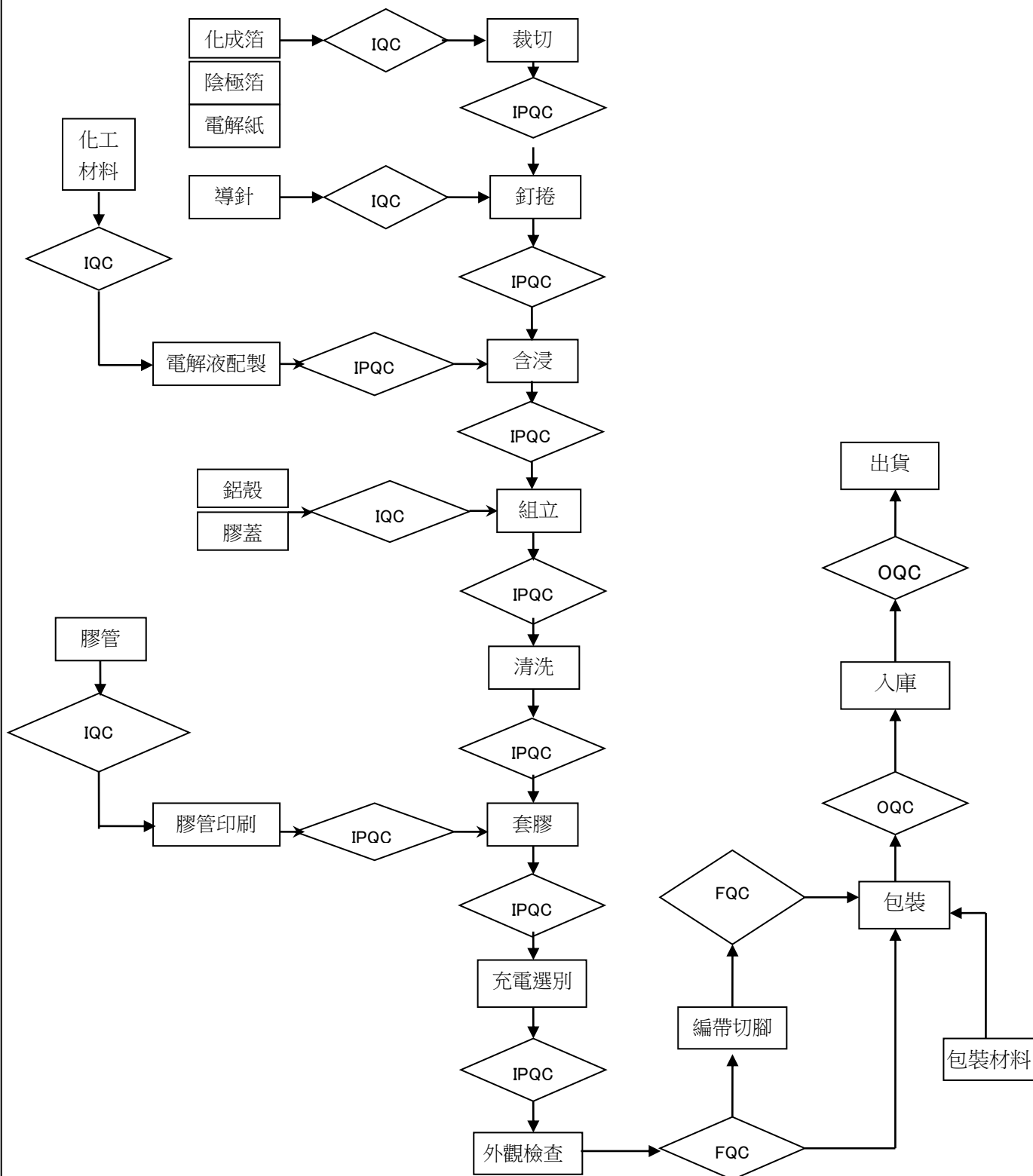

8、铝电解电容器的使用注意事项 Guidelines For Using Aluminum Electrolytic Capacitor

为使您获得电解电容器的最佳性能和延长电解电容器的使用寿命，在使用电解电容器前，请务必阅读本注意事项。

Upon using Aluminum Electrolytic Capacitors, please proper handling and observing to following important points will insure optimum capacitor performance and long life.

1、直流电解电容器是有极性的 DC electrolytic capacitors are polarized.

确定极性，极性标志在电容器的基体上。以免因极性反可能引起电路短路或电容器损坏，当极性不固定或不确定的，使用双极性电容器。注意直流电解电容器不能使用于交流。

Make sure of the polarity .The polarity is marked on the body of the capacitor .Application of the reversed voltage may cause a short circuit or damage to the capacitor. Use bipolar capacitors when the polarity is not determined or unknown. Note that DC electrolytic capacitors can not be used for AC application.

2、双极性电容器 Bipolar capacitors

只适用于脉动电路和极性反转电路中，不适用于纯交流和高纹波电路中。

They are used only in pulse circuits as well as polarity reverse circuits. but not applicable in pure AC or high ripple current.

3、使用电压不要大于额定电压 DO not apply voltage greater than rated voltage .

使用电压大于额定电压，漏电流会增大，可能损坏电容器。建议工作电压为额定电压的百分之七十~八十，电容器在建议的工作电压下使用可延长电容器的寿命。

If a voltage exceeding the rated voltage is applied , the leakage current will increase ,which damage the capacitor. Recommended working voltage is 70 to 80 percent of rated voltage. Using capacitors at recommended working voltage prolongs capacitor life.

4、不要使过量的纹波电流通过电容器 Do not allow excessive ripple current through the capacitor.

流过电容器的纹波电流超过许可值，将会引起电容器发热，电容量减少，损害电容器。通过电容器的纹波电流不要大于允许值，一般不超过额定值的 80%。

The flow of ripple current over permissible ripple current will cause heat of the capacitor, which may decrease the capacitance and damage the capacitor. ripple current on the capacitor must be at or bellow allowable level, generally not more than 80% of the rated current.

5、快速的充放电电路中，使用专门设计的电容器 Use specially designed capacitors for the circuits where charge and discharge are frequency repeated.

在经受快速的周期性充放电电路中，电容器可能受损害，它的寿命因容量下降、温升等原因而缩短，在这种电路中，一定要使用专门设计的电容器。

In the circuit subjected to rapid charge and discharge cycles, capacitors may be damaged, its life may be shortened by capacitance decrease, heat rise, ect. Be sure and use special capacitors in these applications.

6、工作温度范围 Operating temperature range.

电容器的特性随工作温度而变化，在温度较高的情况下，容量、漏电流增大， $\text{tg } \delta$ 减少；在低温情况下，容量和漏电流下降， $\text{tg } \delta$ 增大。电容器在较低的温度下使用会确保延长寿命。

The characteristics of capacitors change with the operating temperature. The capacitance and leakage current increase and $\text{tg } \delta$ decrease at higher temperatures. The capacitance and leakage current decrease and $\text{tg } \delta$ increase at lower temperature. Usage at lower temperature will ensure longer life.

7、使用温度与寿命的关系 Relationship between temperature and life.

电容器的寿命与其使用的温度有关，一般来说，使用温度降低 10°C ，其寿命是额定温度下的 2 倍，计算公式如下：

Life of capacitors has relationship with its used temperature .Generally, if the used temperature is reduced 10°C ,life is prolonged twice at rated temperature. Here is calculating format:

$$L_2 = L_1 \times 2^{\frac{T_1 - T_2}{10}}$$

L_1 —额定温度下的寿命

L_2 —实际温度下的寿命

Life at rated temperature

T₁—额定使用温度

Rated used temperature

Life at actual temperature\

T₂—实际使用温度

Actual used temperature

8、核对工作频率 Check operating frequency.

电解电容器的电容量通常是在 100Hz 或 120Hz 下测得的。然而要记住容量随频率的升高而下降， $\text{tg } \delta$ 随频率的升高而增大，并使周围温度升高。

The capacitance of electrolytic capacitors is usually measured at 100Hz or 120Hz. However, remember that capacitance decrease and $\text{tg } \delta$ increase as the applied frequency becomes higher whereas the ambient temperature becomes higher.

9、长时间存放的电容器，在使用前加额定直流电压处理 Apply rated DC voltage treatment to the capacitors which have been stored for a long time.

长时间的存放，实际对电容器的容量和 $\text{tg } \delta$ 没有多大的影响，然而往往会使漏电流增大，耐压降低。

长时间存放后的电容器处理，首先逐渐施加直流电压至额定电压，然后再使用。

Long periods of storage have virtually no effect on a capacitor's capacitance and $\text{tg } \delta$. Such periods tend, however, to increase leakage current and decrease withstand voltage.

After removing capacitors from long-duration storage, First apply a gradually increasing DC voltage to rated voltage and then use them.

10、电容器外壳与阴极端是不绝缘的 The capacitor case is not insulated from the cathode terminal.

电容器的外壳与阴极端是通过电解液连接的，如果电容器的外壳必须与线路绝缘，则电容器的安装位置处，一定要采取绝缘措施。

The capacitor's case and cathode terminal connect through the electrolyte. If the case is to be completely insulated, that insulation must be at the capacitor's mounting point.

11、电容器的端子或引线不要施加过大的力 Do not apply excessive force to the terminals and leads.

过大的力施加到端子或引线上，可能引起引线的断裂或端子分裂，转而引起内部连接的破坏。

The excessive strong force applied to the terminals and lead wires may cause leads to break or terminals to separate and, in turn, cause the internal contact to fail.

12、浸焊料后，线路板的清洗 Cleaning of the circuit board after solder dipping.

清洗线路板以去除焊剂或其它附着物。为了保护塑料套管，印刷标志以及封口材料不被破坏，电容器不能用卤化物或类似溶剂作为电容器清洗用，如三氯乙烯，二甲苯或酮类等。建议使用的清洗溶剂为：甲醇，异丙醇，乙醇，异丁醇，石油醚，丙醇和一般的洗涤剂。

Cleaning circuit boards to remove flux or other extraneous matter. To ensure protection for sleeve, marking and sealing materials on capacitor body, capacitor should never be washed or cleaned by halogens agents or solvents such as trichlorethylene, xylene or acetone etc. Recommended cleaning solvents. Methanol, isopropanol ethanol, isobutanol, petroleum ether, propane and/or commercial detergents.

13、焊接时注意温度和持续的时间 Be cautious of the temperature and duration when soldering.

烙铁应与电容器的塑料绝缘套管保持一定的距离。当电容器浸于焊料槽时，建议温度在 260℃ 以内，时间不要超过 10 秒钟，以避免电容器组件受损。

Soldering irons should be kept away from the vinyl insulated sleeves of capacitor. When the capacitor dipped in solder bath, recommendable within 260℃ and 10 seconds to avoid damage of capacitor unit.

14、印刷线路板上孔的布局 Hole positions on the circuit board.

设计印刷线路板时，安装孔距应等于引线间距，当孔距大于或小于引线间距时，安装电容器时，将有应力作用到引线上，可能引起短路，电路损坏，漏电流增大。

另外，焊料可能通过所打的孔及后加工零件的引线孔溅落到塑料套管上，造成损伤，所以要认真考虑孔的布局。

When designing a circuit board, space the position holes equally to the space between lead wires. When the spacing is either greater than or less than the capacitor's leads, mounting the capacitor will apply to the leads, causing short circuits, broken circuits, and increased current.

Otherwise, through-holes on the circuit board as well as lead holes of post-process parts can result in solder splashing onto the vinyl sleeve, causing damage. Consider hole positions carefully.