

REV.	LOCAS.	DESCRIPTION	DATE	DRAWN
01	NEW	INITIAL RELEASE.	2009.08.24	曹 熙
02	△	變更圖號	2011.06.17	曹 熙

F
E
D
C
B
A

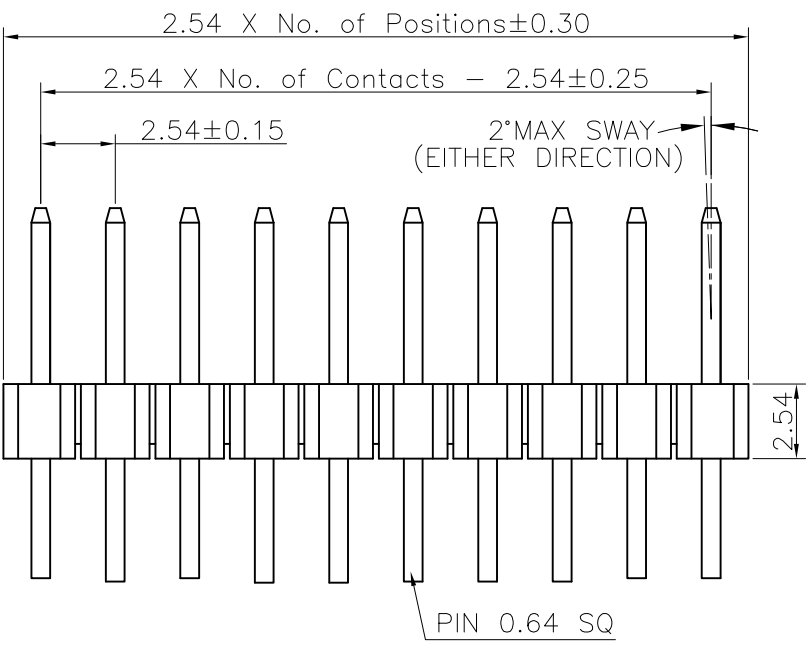

Specifications
 Current Rating: 3Amp
 Insulation Resistance: 1000MΩMin.
 Dielectric Withstanding Voltage: 600VAC
 Contact Resistance: 20mΩMax.
 Operating Temperature: -40°C to +105°C
 Materials
 Contact Material: Brass
 Insulator Material: Thermoplastic, UL 94V-0 PBT or the equivalent material
 All materials must meet Greenconn requirement for environment protection.

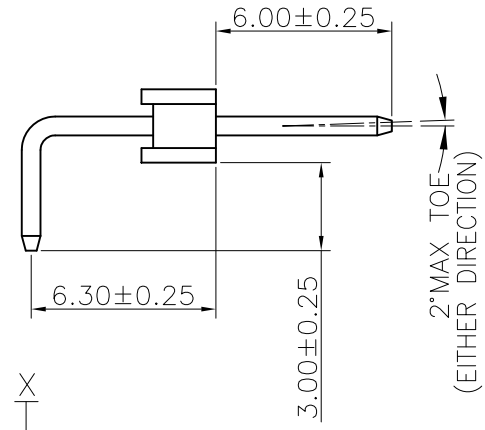
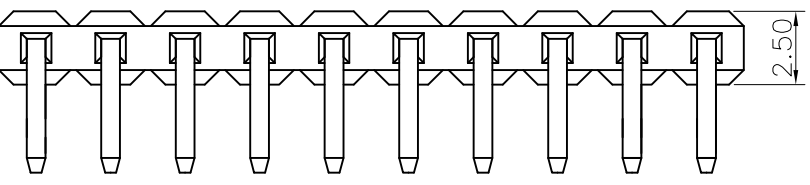

Ordering Information

G PHB101 - XX XX A 001 A 1 B X

No. of Pins per Row 01~40
 Standard Plating 02=Gold Flash
 Selective Plating 01=Tin 05=Gold Flash/Tin
 Color 1=Black
 Standard Packing A=Box
 Selective Packing C=Tube

Recommended P.C.Board Layout
 (Tolerance: ±0.05)

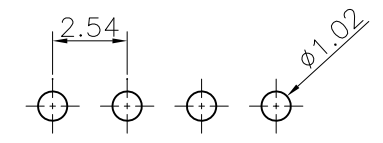

A

格稜股份有限公司
Greenconn Corporation

GENERAL TOLERANCE		DESIGN: 曹 熙	DATE: 2011.06.17	DWG. NO.	TITLE. 2.54 PIN HEADER SINGLE ROW R/A TYPE CONNECTOR
X.*±5.0°	X.±0.30	CHECKED: 劉北平	DATE: 2011.06.17	GPHB101-CA1AB	
.X.*±3.0°	.X.±0.25	AUDITED: 李 輝	DATE: 2011.06.17	PART NO.	
.XX.*±2.0°	.XX±0.15	APPROVED: cc_li	DATE: 2011.06.17	GPHB101-XXXX A001A1BX	
.XXX.*±1.0°	.XXX±0.10				

REV.	UNIT.	SCALE.	PAGE.
02	mm	4:1	1/1