

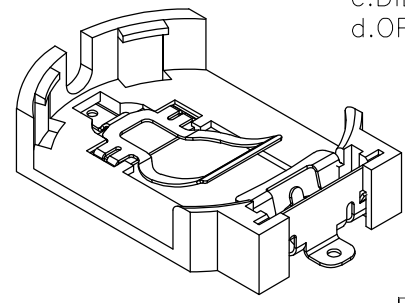

REV.	ECN NO.	REVISED	DATE

NOTE:

- 1.MATERIAL:
a.HOUSING:PPA
b.CONTACT:PHOSPHOR BRONZE
(SURFACE PLATING: Au1u")
SEE ORDERING INFORMATION
- 2.ELECTRIC:
a.CONTACT RESISTANCE: 30 MILLIOHMS MAX
b.INSULATION RESISTANCE: 100 MEGA OHMS MIN
c.DIELECTNIC VOLTAGE: 500V AC ONE SEC LEVEL
d.OPERATING TEMPERATURE: -25° C~ +85° C

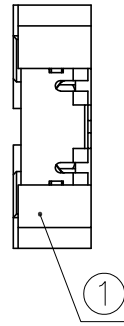
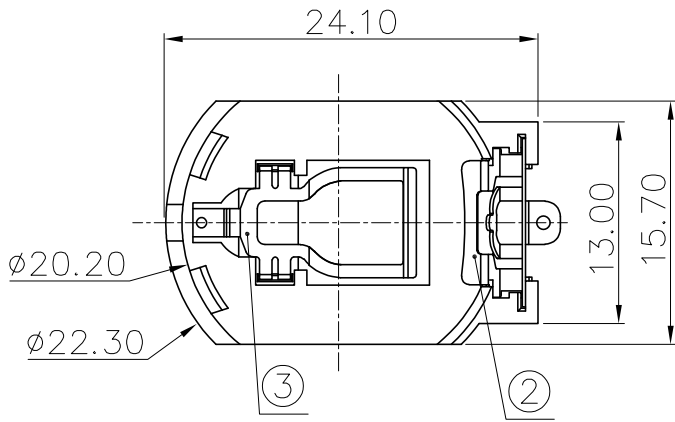

ORDERING INFORMATION
BS-08-B2BA013

电池座系列
BS-08系列
SMT 180° TYPE

PLATING:
A-Au1U"
J-Ni100U"~120U"
K-Sn100U"~120U"

MATERIAL:
1A-PBT BLACK
1B-PA66 BLACK
2A-PPA BROWN
2B-PPA BLACK
3A-PPS BROWN
3B-PPS BLACK
4A-LCP WHITE
4B-LCP BLACK

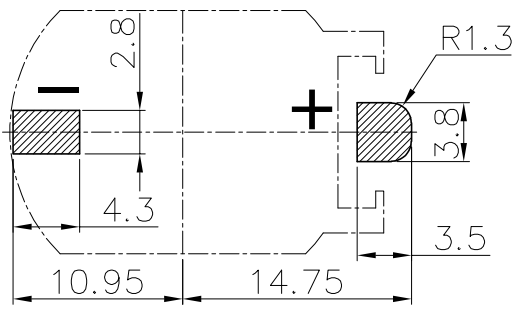
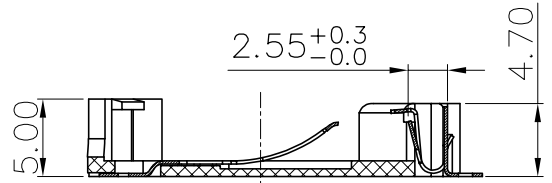

PCB Layout Diagram
Top View

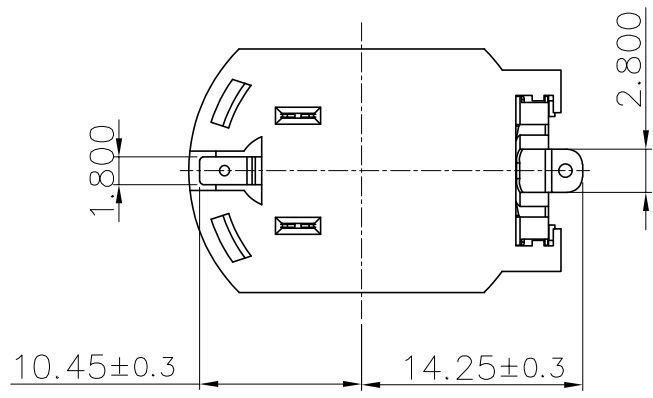

3	TERMINAL(-)	1	PHOSPHOR BRONZE, T=0.20mm	Gold Plating and Ni Under-Plating
2	TERMINAL(+)	1	PHOSPHOR BRONZE, T=0.20mm	Gold Plating and Ni Under-Plating
1	HOUSING	1	PPA	BLACK
NO.	PART NAME	Q'TY	MATERIAL	PLATING & COLOR

UNLESS OTHERWISE SPECIFIED TOLERANCES		MYOUNG 美阳 www.meiyangdz.com	
DECIMALS: X :±0.30 X.X :±0.25 X.XX :±0.20 X.XXX :±0.10	ANGLES: X :±1° X.X :±0.5°	DSND YangFeng	DATE 2021-06-01
WEIGHT: 9		CHKD ZhouRuicai	DATE 2021-06-01
SHEET 1 OF 1		APVD XueShunyong	DATE 2021-06-01
UNIT: mm	REV.: A/0	SCALE:	VIEW:
OBJECT: MY	DRAW NO.:MY-CP-0075	SIZE: A4	TITLE: BS-2032-8K 5MM SMT
PART NO.: BS-08-B2BA013		TITLE: BS-2032-8K 5MM SMT	