



REV.	ECN NO.	REVISED	DATE

NOTE:

- 1.MATERIAL:
 - a.HOUSING:High Temp Nylon BLACK
 - b.SPRING: Stainless Steel (SURFACE PLATING: Au1u")
SEE ORDERING INFORMATION
- 2.ELECTRIC:
 - a.DIELECTNIC VOLTAGE: 270V AC ONE SEC LEVEL
 - b.OPERATING TEMPERATURE: -10° C~ +100° C

ORDERING INFORMATION

BH-123A-B*006**

电池盒 — PLATING:
 A-Au1U"
 J-Ni100U"~120U"
 K-Sn100U"~120U"

电池型号 —

SMT 180° TYPE — MATERIAL:
 1A-PP BLACK
 1B-PA66 BLACK
 2A-PPA BROWN
 2B-PPA BLACK
 3A-PPS BROWN
 3B-PPS BLACK
 4A-LCP WHITE
 4B-LCP BLACK
 5B-NYLON BLACK

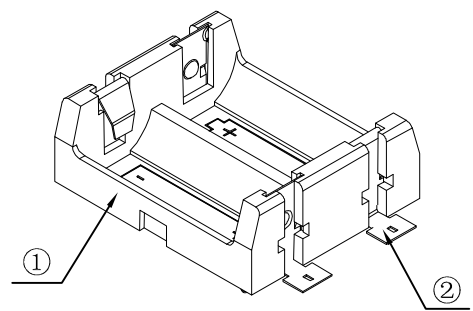
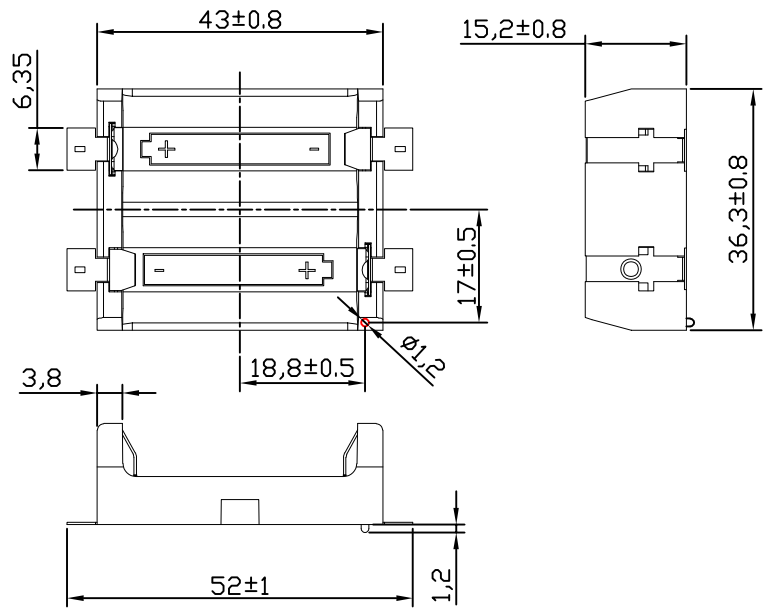

3D View

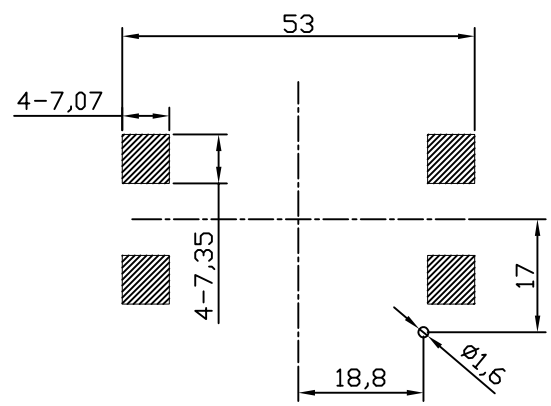

PCB Layout Diagram
TOP View



UNLESS OTHERWISE SPECIFIED TOLERANCES		MYOUNG 美阳 www.meiyangdz.com			
DECIMALS: X :±0.30 X.X :±0.25 X.XX :±0.20 X.XXX :±0.10	ANGLES: X :±1° X.X :±0.5°	DSND	YangFeng	DATE	2023-01-07
		CHKD	ZhouRuicai	DATE	2023-01-07
		APVD	XueShunyong	DATE	2023-01-07
WEIGHT:		SCALE:	SIZE: A4	VIEW:	⊕ ⊖
SHEET 1 OF 1		UNIT: mm	REV.: A/1	OBJECT: MY	TITLE: 电池盒BH-123A-2J Au SMT
		PART NO.:		BH-123A-B5BA006	
		DRAW NO.:		WD-CP-0257	

②	CONTACT	2	Stainless Steel, 0.35MM	Au-Plating
①	HOUSING	1	High Temp Nylon	BLACK
NO.	PART NAME	Q'TY	MATERIAL	PLATING & COLOR