

SPECIFICATIONS

Current Rating: 3 Amps
 Insulation Resistance: 1000MΩ Min
 Contact Resistance: 20mΩ Max
 Withstanding Voltage: AC 1000V
 Operation Temperature: -40° to +105°
 Contact Material: Brass
 Insulator Material: Polyester (UL 94V-0) PA6T
 Standard:
 Max. Processing Temp: 200° C for 30-60seconds
 (220° C for 10seconds)

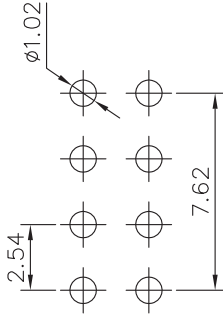

RECOMMEND P. C. B LAYOUT
 PCB TOLERANCE: ±0.05 (TOP VIEW)

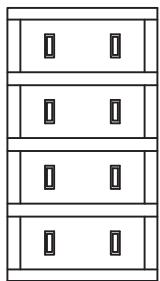
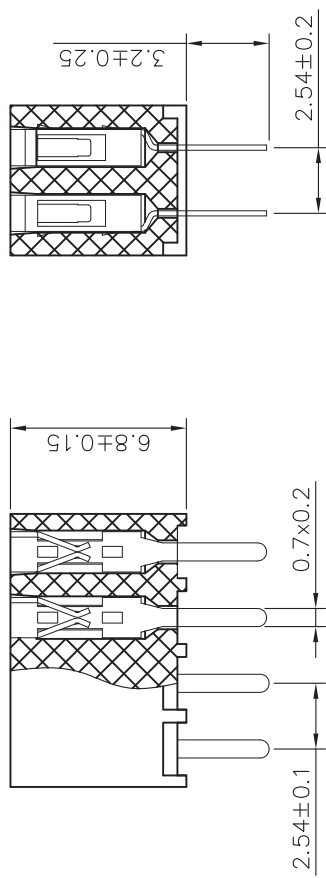

HJ-2.54-FH-2-XX-68-S-32-58-G0-U-B

- (1) Pin Spacing: 254=2.54mm
- (2) Product Name: FH=Female Header
- (3) No. of Rows: 1=Single Row ; 2=Dual Row
- (4) No. of Pins Per Row: 1~40
- (5) Insulator Material Height: 50=5.0mm; 85=8.5mm
- (6) Connector Type: S=Straight; R=Right Angle; M=SMT
- (7) Connector Material Length: 30=3.0mm; 32=3.2mm
- (8) Insulator Material Width: 50=5.0mm; 55=5.5mm
- (9) Contact Plating: G0=Gold Flash; AU15=Au 1.5u"
- (10) Connector Material Type: U=U Type; Y=Y Type
- (11) Insulator Material Option:
 A=BK-PBT; B=BK-PA6T; C=BK-PA46; D=KB-LCP; S=Special

| No. of | DIM. A | DIM. B | No. of | DIM. A | DIM. B | No. of | DIM. A | DIM. B |
|--------|--------|--------|--------|--------|--------|--------|--------|--------|
| 1 | 0.00 | 2.54 | 11 | 25.40 | 27.94 | 21 | 50.80 | 53.34 |
| 2 | 2.54 | 5.08 | 12 | 27.94 | 30.48 | 22 | 53.34 | 55.88 |
| 3 | 5.08 | 7.62 | 13 | 30.48 | 33.02 | 23 | 55.88 | 58.42 |
| 4 | 7.62 | 10.16 | 14 | 33.02 | 35.56 | 24 | 58.42 | 60.96 |
| 5 | 10.16 | 12.70 | 15 | 35.56 | 38.10 | 25 | 60.96 | 63.50 |
| 6 | 12.70 | 15.24 | 16 | 38.10 | 40.64 | 26 | 63.50 | 66.04 |
| 7 | 15.24 | 17.78 | 17 | 40.64 | 43.18 | 27 | 66.04 | 68.58 |
| 8 | 17.78 | 20.32 | 18 | 43.18 | 45.72 | 28 | 68.58 | 71.12 |
| 9 | 20.32 | 22.86 | 19 | 45.72 | 48.26 | 29 | 71.12 | 73.66 |
| 10 | 22.86 | 25.40 | 20 | 48.26 | 50.80 | 30 | 73.66 | 76.20 |

HJ-Tech 东莞市皇捷通讯科技有限公司
 DONGGUAN HUANGJIE COMMUNICATION TECHNOLOGY CO., LTD.

| | | | |
|--------------------------------------|---------------|--|-------------|
| UNLESS OTHERWISE SPECIFIED TOLERANCE | | DRAWN NAME: | |
| X : ±0.3 | X° : ±5° | 2.54FH 2x4PIN 6.8塑高 180° PC3.2 塑宽 5.8 镀金 Y型 PA6T | |
| X.X : ±0.2 | X.X° : ±1° | SIZE | A4 |
| X.XX : ±0.1 | X.XX° : ±0.5° | SCALE | N:1 |
| CHECKED: LU JING NUAN 2020/03/25 | | REV | B |
| | | UNIT | mm |
| | | PROJECT | 17-0039-002 |
| | | APPROVED: | |
| | | PAGE | 1/1 |