

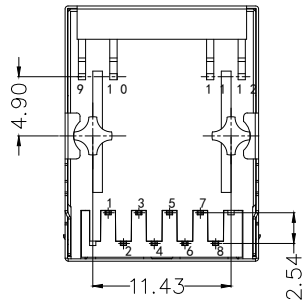
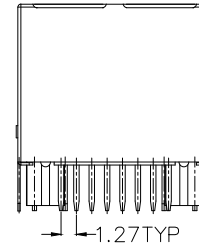
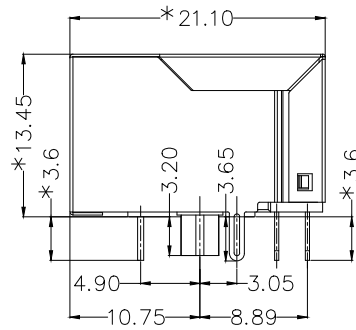
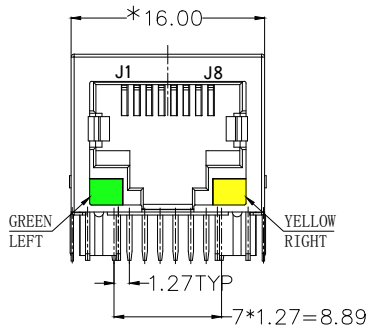
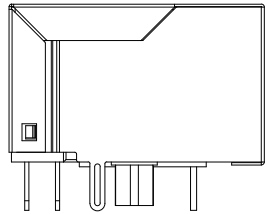

MATERIAL:

HOUSING : PBT,UL94V-0,BLACK.
 TERMINALS BRACKET: PBT,UL94V-0,BLACK.
 SHIELD: C2680,T=0.20MM,NICKEL PLATING ON ALL AREA.
 TERMINAL: PHOSPHOR BRONZE C5210,T=0.35MM,
 6U" GOLD PLATING ON CONTACT AREA.

MECHANICAL:

DURABILITY : 750 CYCLES MIN.
 MATING FORCE : 23N MAX.
 OPERATING TEMPERATURE: -40°C~+85°C.
 STORAGE TEMPERATURE: -40°C~+85°C.
 ALL CRITICAL DIMENSIONS WITH "*"



			GENREL TOLERANCE		制图 DRAWING		 深圳市华灿天禄电子有限公司 ShenzhenhuacantianluELECTRONICS CO.,LTD			
			DIM	TOL	审核 CHECK					
			X.X	±0.30	批准 APPROVAL		产品名称 TITLE	网络插座 (插件) TAB-DOWN 1x1 10/100BASE)	版本 REV.	A
1			初版发行				产品料号 PART NO.	HC913129AE-907-A	单位 UNITS	mm
序号 No.	变更内容 MODIFY CONTENT	日期 MODIFY DATE	Angle	±3.0°	投影 Projection		材料 MATERIAL		页次 SHEET	1/4

RECOMMENDED PANEL CUTOUT (REFERENCE ONLY):

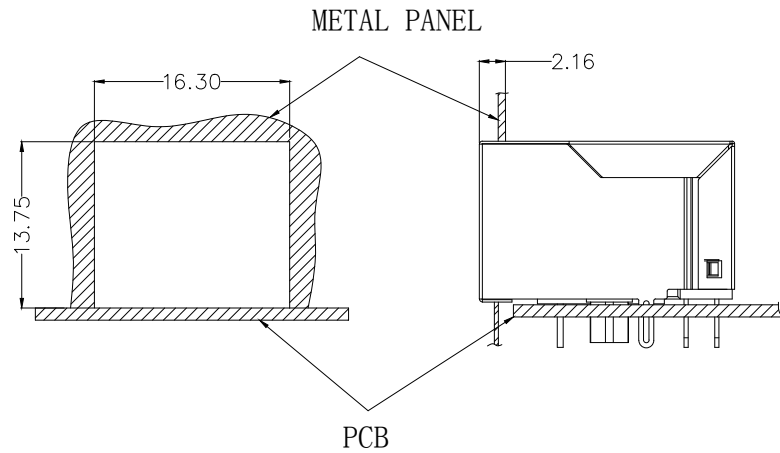

UNIT: MM / INCH
 TOLERANCES: ± 0.10 / 0.004
 REFERENCE ONLY

KEEP-OUT AREA (COMPONENT SIDE VIEW):

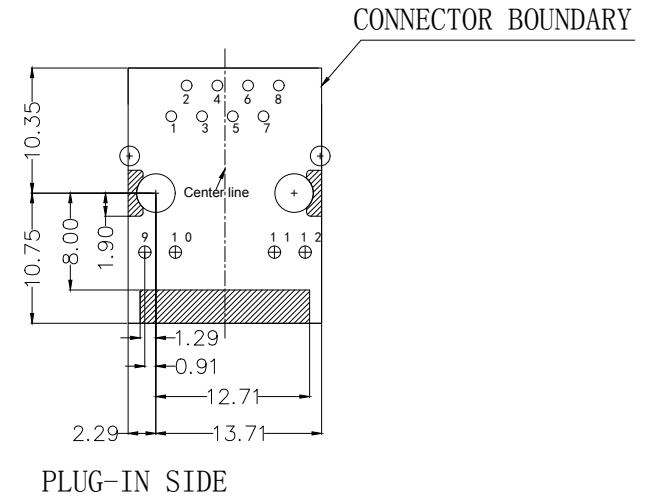

UNIT: MM / INCH
 TOLERANCES: ± 0.10 / 0.004

			GENERAL TOLERANCE		制图 DRAWING		深圳市华灿天禄电子有限公司 ShenzhenhuacantianluELECTRONICS CO., LTD					
			DIM	TOL	审核 CHECK		产品名称 TITLE		网络插座 (插件) TAB-DOWN 1x1 10/100BASE)	版本 REV.	A	
			X.X	± 0.30	批准 APPROVAL		产品料号 PART NO.		HC913129AE-907-A	单位 UNITS	mm	
1			初版发行				投影 Projection			材料 MATERIAL	页次 SHEET	2/4
序号 No.	变更内容 MODIFY CONTENT	日期 MODIFY DATE	Angle	$\pm 3.0^\circ$								

PCB SIDE TO PHY

CABLE SIDE

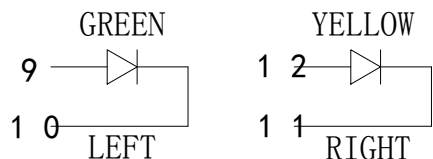
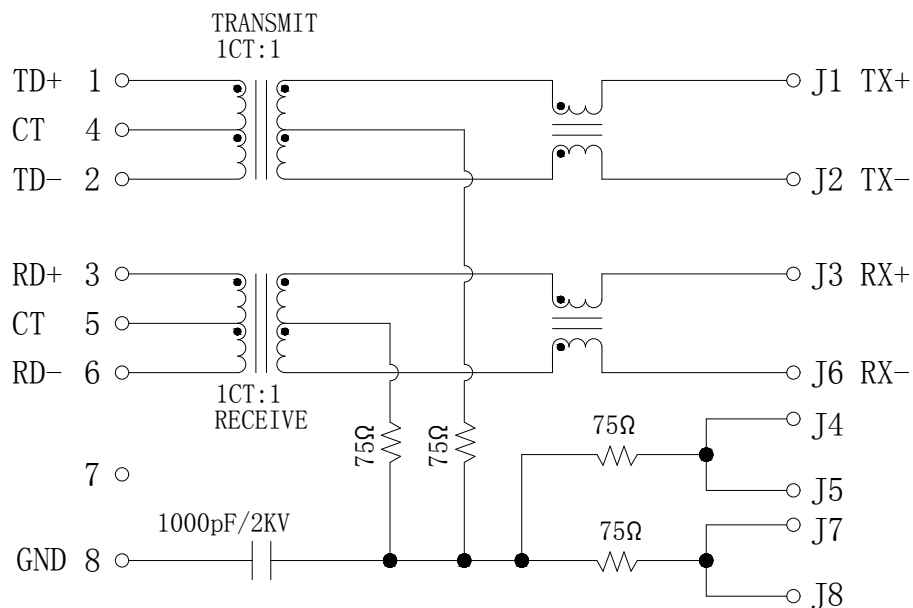

Electrical:

- Turn ratio: 1~2: J1~J2=1CT:1CT(±2%).
3~6: J3~J6=1CT:1CT(±2%).
- OCL: 350uH Min. at 100KHz 100mV 8mA DC.
- Insertion Loss: -1.0 dB Max 1~100MHz.
- Return loss: -20dB Min 1~10MHz;
-16dB Min 10~30MHz.
-12dB Min 30~60MHz.
-10dB Min 60~80MHz.
- Cross talk: -40dB Min 1~30MHz;
-35dB Min 30~60MHz;
-30dB Min 60~100MHz;
- CMR: -30dB Min 1~100MHz;
- Hi-Pot: 1500V AC & 2250V DC
6S 1mA PRI TO SEC

LED Specification

Standard LED Color	LED Wavelength	Foward(A)	Foward(V)
Green	568nm	20mA	1.85-2.45V
Yellow	585nm	20mA	1.7-2.2V

			GENERAL TOLERANCE		制图 DRAWING		深圳市华灿天禄电子有限公司 ShenzhenhuacantianluELECTRONICS CO., LTD					
			DIM TOL		审核 CHECK							
			X.X ±0.30		批准 APPROVAL		产品名称 TITLE		网络插座 (插件 TAB-DOWN 1x1 10/100BASE)		版本 REV.	A
1			初版发行		X.XX ±0.10		产品料号 PART NO.		HC913129AE-907-A		单位 UNITS	mm
序号 No.	变更内容 MODIFY CONTENT		日期 MODIFY DATE		Angle ±3.0°		投影 Projection		材料 MATERIAL		页次 SHEET	3/4

PROFILE OF WAVE SOLDER

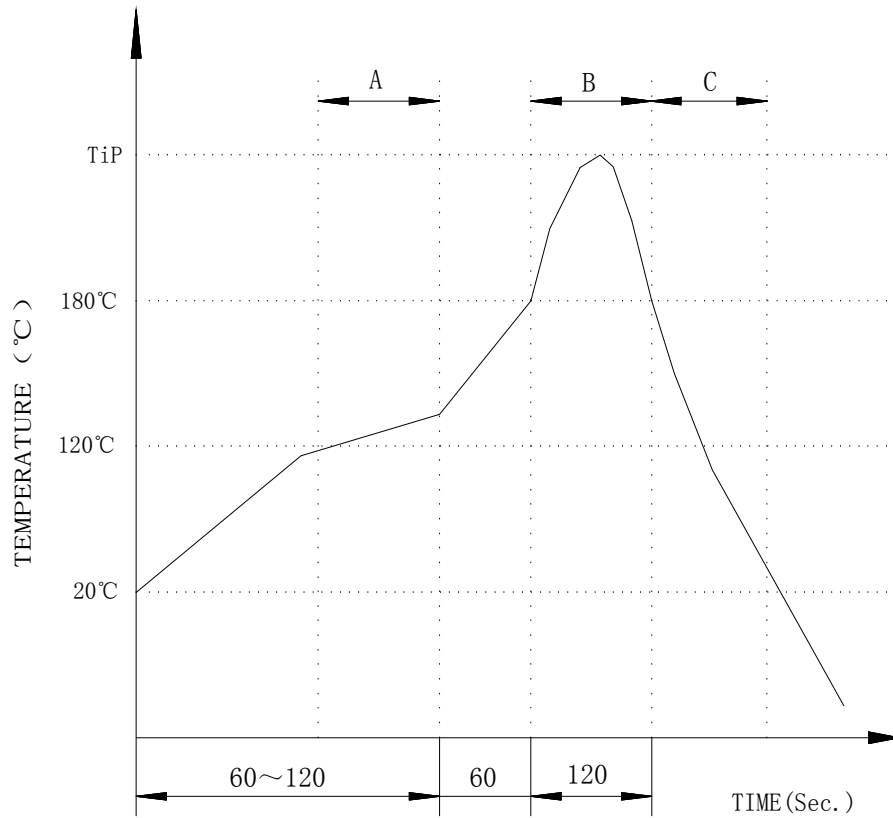

A.Preheating B.Soldering C.Gradual Cooling
 Tip temperature:260±5°C.
 Tip temperature time:5Sec Max.
 Tip melting point of Sn96.5/Ag3/Cu0.5:217°C.

Remarks: after wave soldering, the plastic positioning columns of the product which under the PCB will be slightly melted, but it won't affect its function.

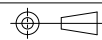
			GENEAL TOLERANCE		制图 DRAWING	 深圳市华灿天禄电子有限公司 ShenzhenhuacantianluELECTRONICS CO.,LTD				
			DIM	TOL	审核 CHECK	产品名称 TITLE		网络插座(插件) TAB-DOWN 1x1 10/100BASE)	版本 REV.	A
			X.X	±0.30	批准 APPROVAL	产品料号 PART NO.		HC913129AE-907-A	单位 UNITS	mm
1	初版发行		X.XX	±0.20	比例 SCALE	材料			页次 SHEET	4/4
序号 No.	变更内容 MODIFY CONTENT	日期 MODIFY DATE	X.XXX	±0.10	投影 Projection					
			Angle	±3.0°		MATERIAL				