

REV.	DESCRIPTION	DATE
A/0	新版发行	2023/05/09

技术要求:

- 1、塑件材料: LCP (UL-94V-0)
- 2、接触件: 黄铜镀锡
- 3、接触电阻: $\leq 30m\Omega$
- 4、绝缘电阻: $\geq 1000M\Omega$
- 5、额定电压: 250V AC DC
- 6、额定电流: 7.0A AC DC
- 7、耐压: 能承受1000V AC/Minute
- 8、工作温度: $-25^{\circ}\sim\sim+85^{\circ}$
- 9、可焊性试验: 浸锡面积 $\geq 95\%$ 温度 260° ,时间 2.5 ± 0.5 秒
- 10、铅和镉等六大有害物质含量要符合环保要求

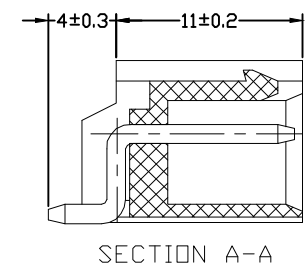
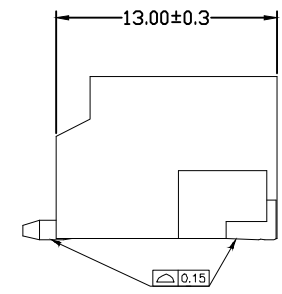
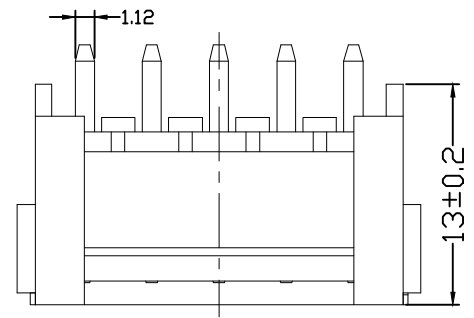
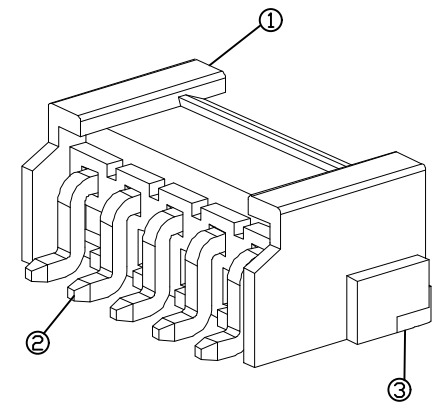
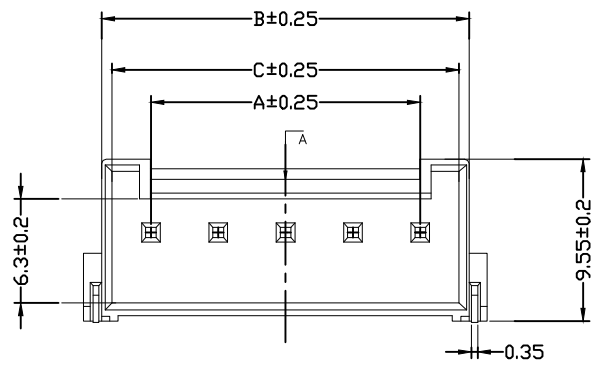

Pin	A	B	C
2	3.96	9.8	8.6
3	7.92	13.76	12.56
4	11.88	17.72	16.52
5	15.84	21.68	20.48
6	19.8	25.64	24.44
7	23.76	29.6	28.4
8	27.72	33.56	32.36
9	31.68	37.52	36.32
10	35.64	45.44	40.28

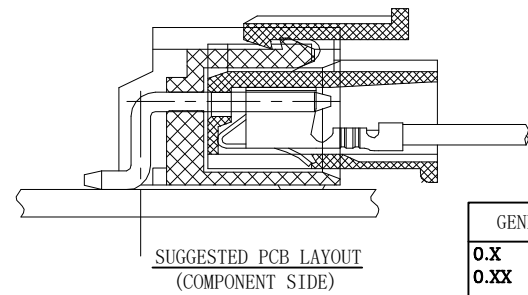
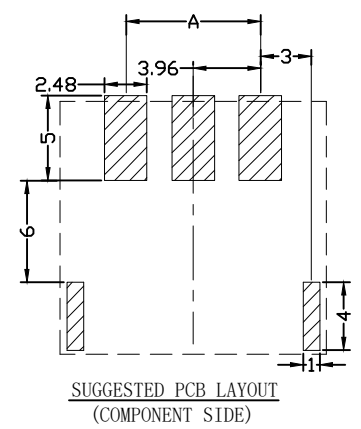

序号	名称	材料	数量	附注
3	弹片 Fitting Nail	黄铜	2	电镀层: 整个表面镀层30u"MIN, 厚度 80u"MIN.
2	端子 Contact	黄铜	n×1	电镀层: 整个表面镀层30u"MIN, 厚度 80u"MIN.
1	基板 Wafer	LCP (UL94V-0)	1	料

GENERAL TOLERANCES				DRAWN BY 绘图者	
0.X	±0.25	X.*	±3°	CHK. BY	审核者
0.XX	±0.12			APRV. BY	批准人
0.XXX	±0.05	X.X*	±0.5°	DRAWING NO.	
UNIT	SIZE	SCALE		10F1	
MM	A4	1:1		TITLE	

 **兆星精密电子 (深圳) 有限公司**

SHEET 10F1 PROD. NAME VH 3.96 卧贴 4P PART NO. ZX-VH3.96-4PWT

借用登记

旧底图总号

底图总号

签字

日期