

修订	标记	修改摘要	签名	日期
REV	MARK	REVISION DESCRIPTION	SIGNATURE	DATE
AO		NEW DWG		2016-03-12

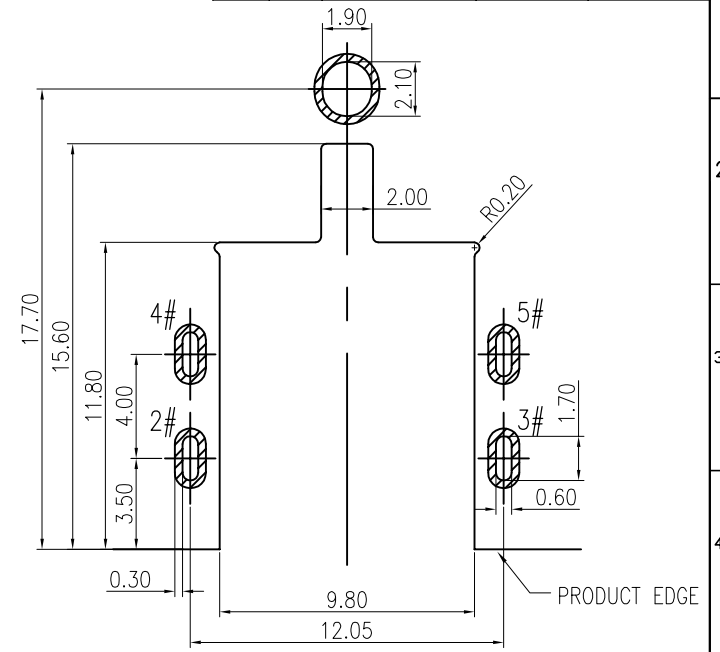

- TOP VIEW TOLERANCE: ± 0.05
 SPECIFICATION:
- RATING: DC 30V 15A
 - CONTACT RESISTANCE: 30m Ω MAX(INITIAL), 50m Ω MAX(FINAL).
 - INSULATION RESISTANCE: 100 M Ω MIN.
 - WITHSTAND VOLTAGE: 500 VAC
 - INSERTION FORCE: 30N MAX.
 - EXTRACTION FORCE: 3N MIN.
 - DURABILITY: 5,000 CYCLES

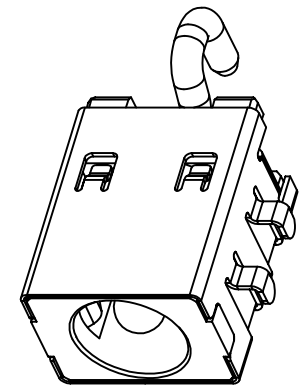
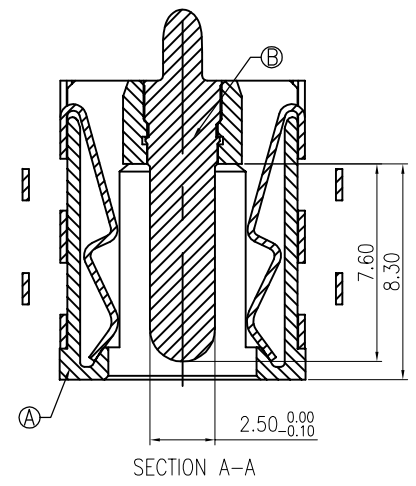
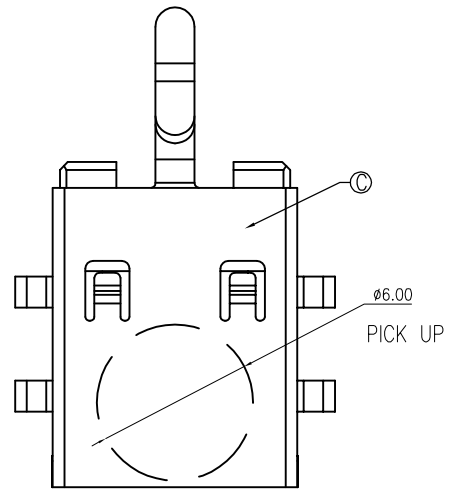
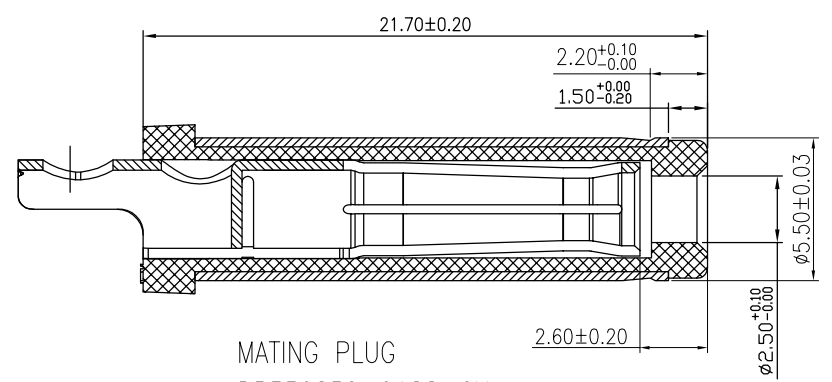
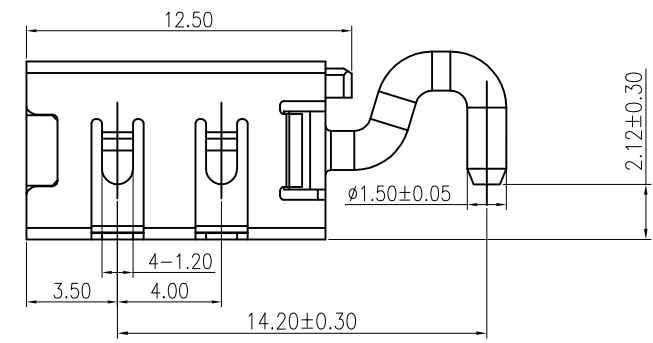
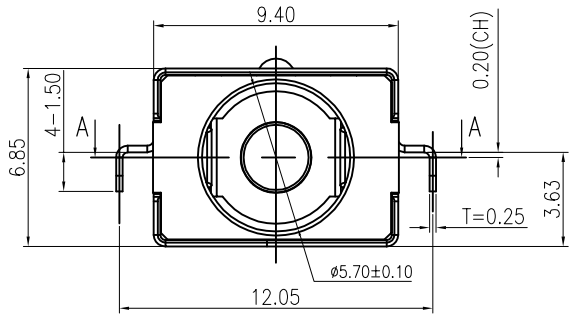

MATING PLUG
 DP550250-0188-6H

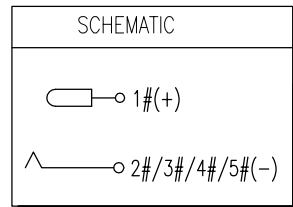

NO.	DESCRIPTION	MATERIAL	REMARKS	QTY
C	SHELL	C5210	Ni 40u" MIN.	1
B	CENTER PIN	BRASS	GOLD FLASH /Ni 40u" MIN.	1
A	HOUSING	PA10T	BLACK	1



深圳市华德共创科技有限公司
 Shenzhen Huade co-create Technology Co., LTD
 电话: 0755-23304126 传真: 0755-29940187

-TOLERANCES- UNLESS OTHERWISE SPECIFIED 公差参数表		TITLE: DC Power Jack 5521 大电流15A, 卧 产品名称: 式, 高可靠, 沉板CL=0.2	
X.X	± 0.30	X.X*	$\pm 3^\circ$
X.XX	± 0.20	X.XX*	$\pm 2^\circ$
X.XXX	± 0.10	X.XXX*	$\pm 1^\circ$
APPD: 核准:	王建国	PART NO: 产品编号:	DC550250-1047-2H
CHECK: 校对:	黄艳兰	DATE	SCALE
DRAW: 绘图:	2016-03-12	UNIT	CODE NUMBER
	1:1	mm	A001