

修 订 REV NO	标 记 MARK	修 改 描 要 REVISION DESCRIPTION	签 名 SIGNATURE	日 期 DATE
		NEW DWG		2016-03-12

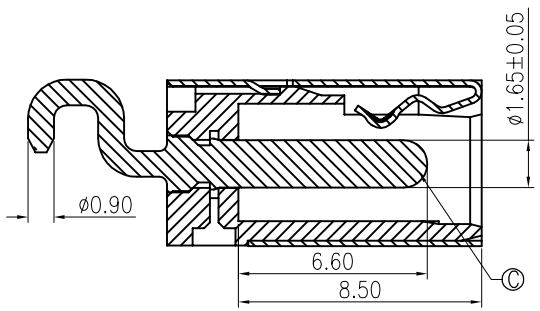

SECTION A-A

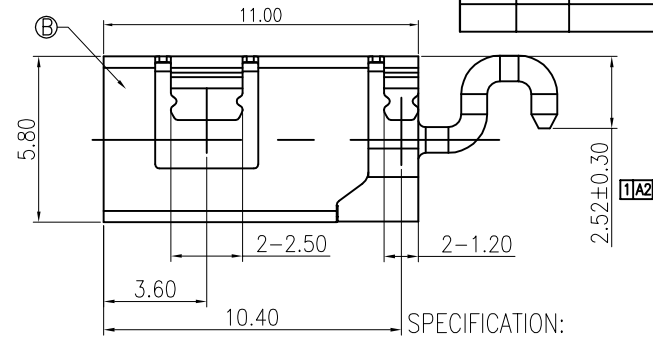
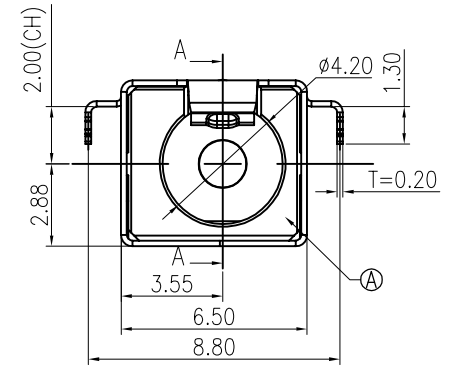

SPECIFICATION:

1. RATING: DC 20V 5A
2. CONTACT RESISTANCE: 30mΩ MAX.
3. INSULATION RESISTANCE: 100 MΩ MIN.
4. WITHSTAND VOLTAGE: 500 VAC
5. INSERTION FORCE: 13N~30N
6. EXTRACTION FORCE: 13N~30N
7. DURABILITY: 5,000 CYCLES

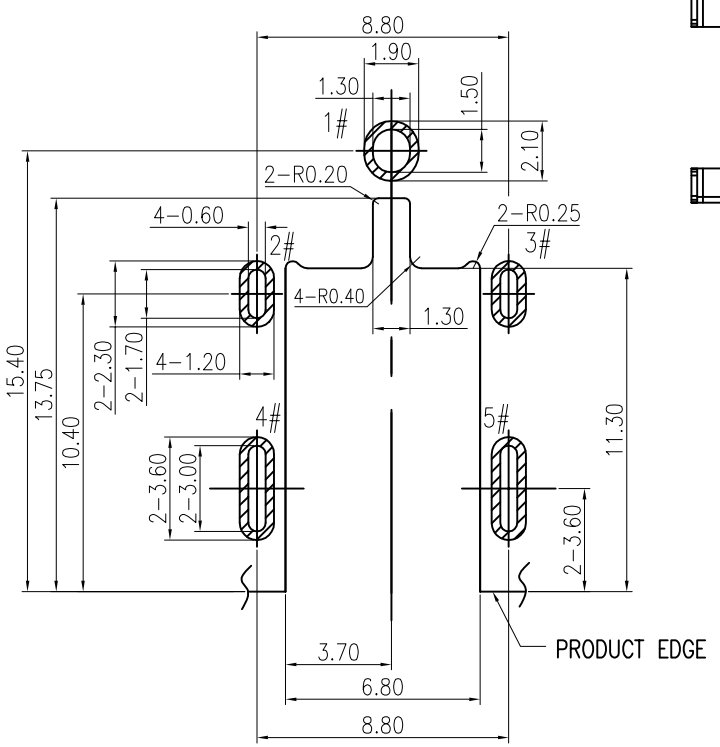
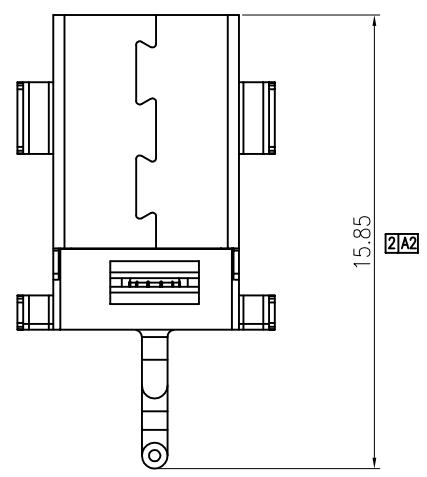

RECOMMENDED PCB LAYOUT(t=1.00)  
TOP VIEW TOLERANCE:±0.05

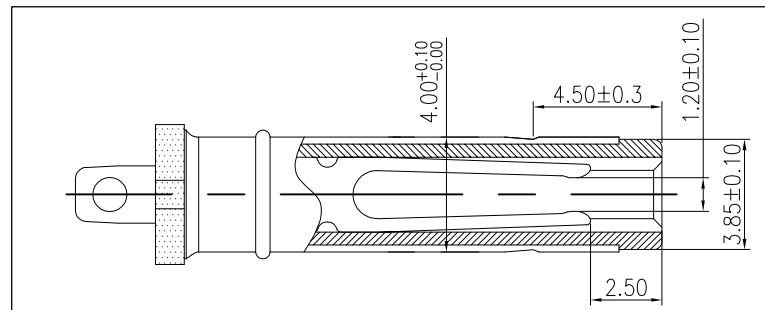

MATING PLUG  
P/N.:DP400170-0001-6H

NO.	DESCRIPTION	MATERIAL	REMARKS	QTY
C	CENTER PIN	HBI59	GOLD FLASH/Ni 50u"	1
B	SHELL	C5210	Ni 50u"	1
A	HOUSING	PA10T	BLACK	1

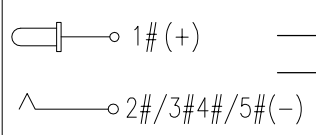

深圳市华德共创科技有限公司  
Shenzhen Huade co-create Technology Co.,LTD  
电话: 0755-23304126 传真: 0755-29940187

-TOLERANCES- UNLESS OTHERWISE SPECIFIED 公差参数表				TITLE: DC Power Jack 4017 大电流8A, 卧式, 产品名称: 高可靠, 沉板CL=2.0				
X.X	±0.30	X.X*	±3°	APPD: 核准:	PART NO: 产品编号: DC400170-0961-3H			
X.XX	±0.20	X.XX*	±2°	CHECK: 校对: 王建业	DATE	SCALE	UNIT	CODE NUMBER
X.XXX	±0.10	X.XXX*	±1°	DRAW: 绘图: 黄艳兰	2016-03-12	1:1	mm	A001

