

TMN30100D

N-Channel Enhancement Mosfet

<p>General Description</p> <ul style="list-style-type: none"> • Low $R_{DS(ON)}$ • RoHS and Halogen-Free Compliant <p>Applications</p> <ul style="list-style-type: none"> • Load switch • PWM 	<p>General Features</p> <p>$V_{DS} = 30V$ $I_D = 100A$ $R_{DS(ON)} = 3.5m\Omega (typ) @ V_{GS} = 10V$</p> <p>100% UIS Tested 100% R_g Tested</p> 
--	---

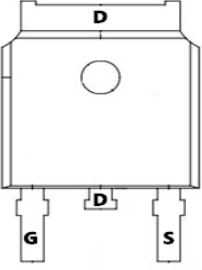

D:TO-252-3

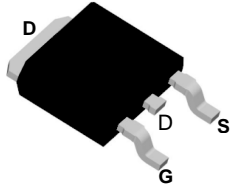

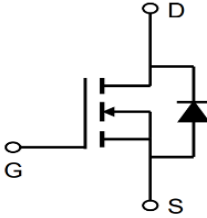

Marking: 100N03

Absolute Maximum Ratings ($T_A = 25^\circ C$ unless otherwise noted)

Symbol	Parameter	Rating	Unit
Common Ratings			
V_{DSS}	Drain-Source Voltage	30	V
V_{GSS}	Gate-Source Voltage	± 20	
I_D	Continuous Drain Current	$T_C = 25^\circ C$	100
		$T_C = 100^\circ C$	39
I_{DM}	Pulsed Drain Current	$T_C = 25^\circ C$	160
P_D	Power Dissipation	$T_A = 25^\circ C$	3.6
P_D	Power Dissipation	$T_C = 25^\circ C$	52
T_{STG}, T_j	Storage Temperature Range	-55 to 150	$^\circ C$
I_D	Continuous Drain Current	$T_A = 25^\circ C$	18
		$T_A = 70^\circ C$	14

Note: Absolute maximum ratings are those values beyond which the device could be permanently damaged. Absolute maximum ratings are stress rating only and functional device operation is not implied.



TMN30100D

N-Channel Enhancement Mosfet

Electrical Characteristics ($T_J=25^{\circ}\text{C}$ unless otherwise specified)

Symbol	Parameter	Test Conditions	Min.	Typ.	Max.	Unit
Static Characteristics						
BV_{DSS}	Drain-Source Breakdown Voltage	$V_{GS}=0V, I_{DS}=250\mu A$	30	-	-	V
I_{DSS}	Zero Gate Voltage Drain Current	$V_{DS}=24V, V_{GS}=0V$	-	-	1	μA
		$T_J=85^{\circ}\text{C}$	-	-	30	
$V_{GS(th)}$	Gate Threshold Voltage	$V_{DS}=V_{GS}, I_{DS}=250\mu A$	1	-	2.5	V
I_{GSS}	Gate Leakage Current	$V_{GS}=\pm 20V, V_{DS}=0V$	-	-	± 100	nA
$R_{DS(ON)}$	Drain-Source On-state Resistance	$V_{GS}=10V, I_{DS}=20A$	-	3.5	5.5	m Ω
		$V_{GS}=4.5V, I_{DS}=15A$	-	5.5	6.8	
Body Diode Characteristics						
V_{SD}	Diode Forward Voltage	$I_{SD}=40A, V_{GS}=0V$	-	0.7	1.3	V
Dynamic Characteristics^e						
C_{iss}	Input Capacitance	$V_{GS}=0V, V_{DS}=10V,$ Frequency=1.0MHz	-	1356	-	pF
C_{oss}	Output Capacitance		-	55	-	
C_{rss}	Reverse transfer capacitance		-	45	-	
$t_{d(ON)}$	Turn-on delay Time	$V_{GS}=10V, V_{DS}=15V$ $R_G=1.8\Omega, I_D=20A, R_L=30\Omega$	-	8	-	nS
t_r	Turn-on rise Time		-	9	-	
$t_{d(OFF)}$	Turn-off delay Time		-	32	-	
t_f	Turn-off rise Time		-	6	-	
Gate Charge Characteristics^e						
Q_g	Total Gate Charge	$V_{DS}=15V, V_{GS}=10V, I_{DS}=20A$	-	23	-	
Q_{gs}	Gate-Source Charge		-	5	-	
Q_{gd}	Gate-Drain Charge		-	3	-	

Note: 1. Pulse test: pulse width $\leq 300\mu\text{s}$, duty cycle $\leq 2\%$

2. Static parameters are based on package level with recommended wire bonding

Typical Performance Characteristics

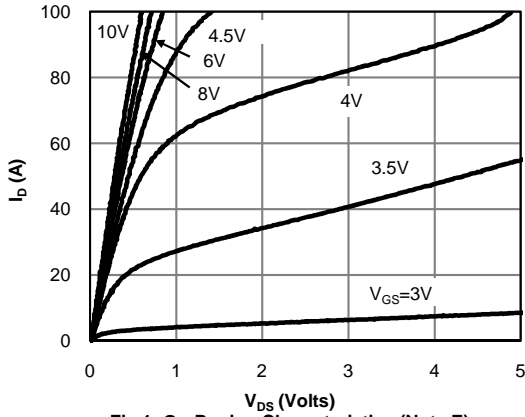

Fig 1: On-Region Characteristics (Note E)

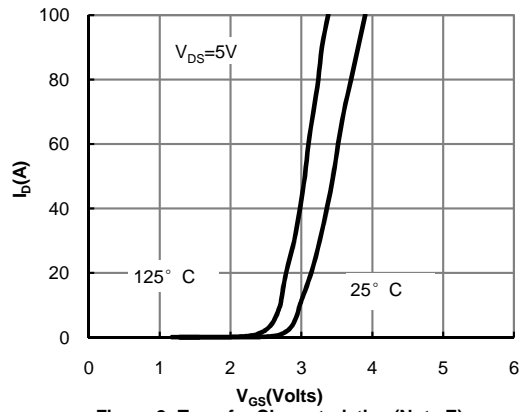

Figure 2: Transfer Characteristics (Note E)

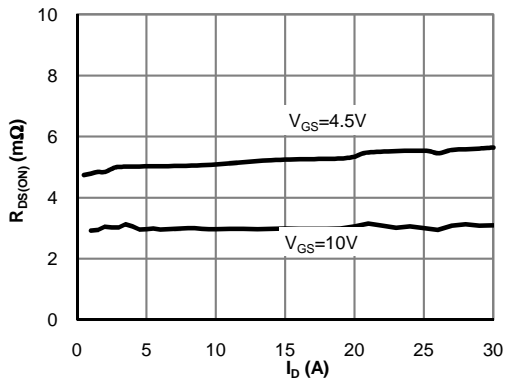

Figure 3: On-Resistance vs. Drain Current and Gate Voltage (Note E)

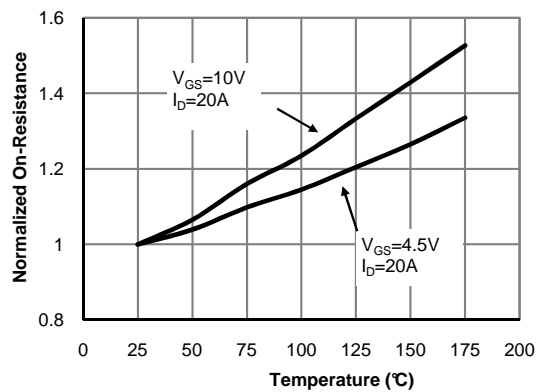

Figure 4: On-Resistance vs. Junction Temperature (Note E)

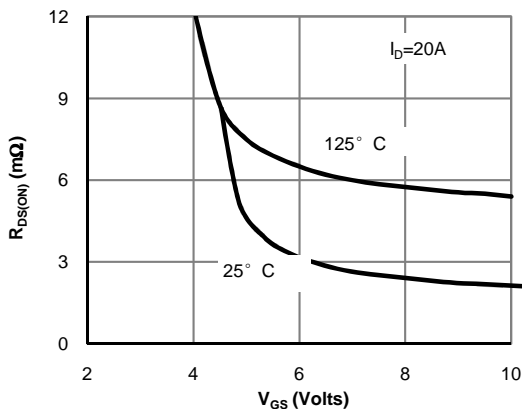

Figure 5: On-Resistance vs. Gate-Source Voltage (Note E)

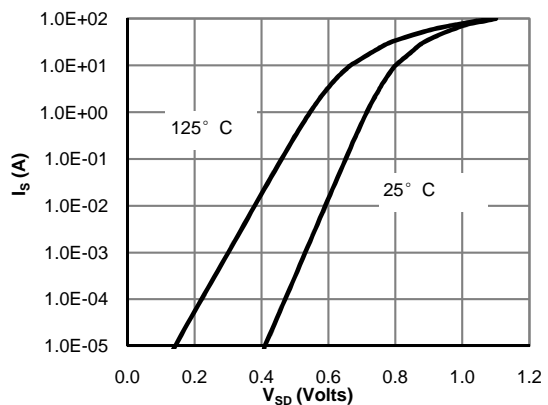

Figure 6: Body-Diode Characteristics (Note E)

TMN30100D

N-Channel Enhancement Mosfet

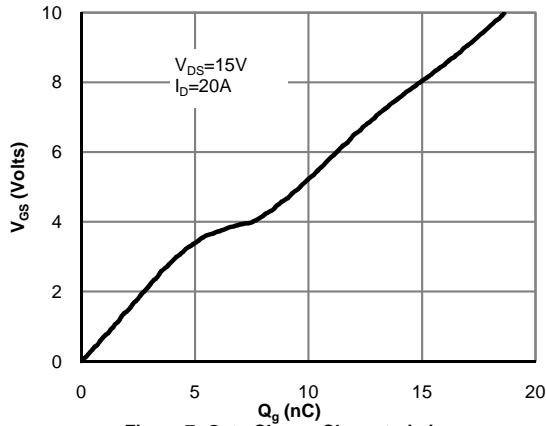

Figure 7: Gate-Charge Characteristics

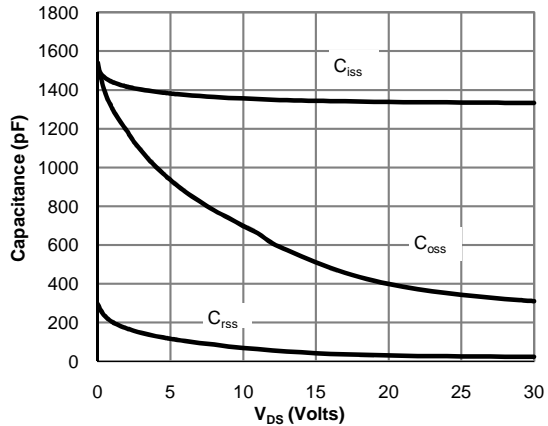

Figure 8: Capacitance Characteristics

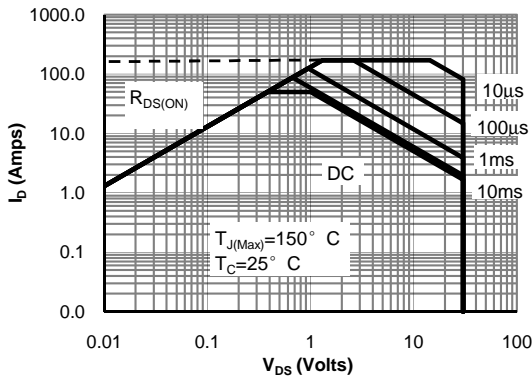

Figure 9: Maximum Forward Biased Safe Operating Area (Note F)

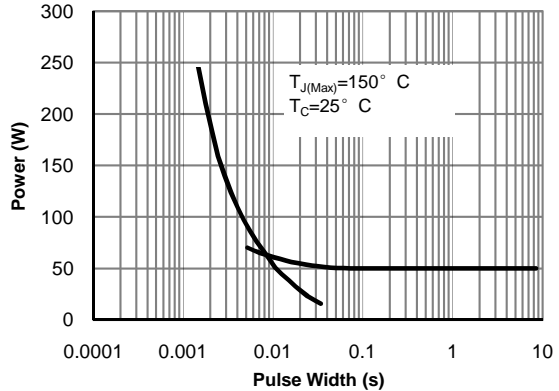

Figure 10: Single Pulse Power Rating Junction-to-Case (Note F)

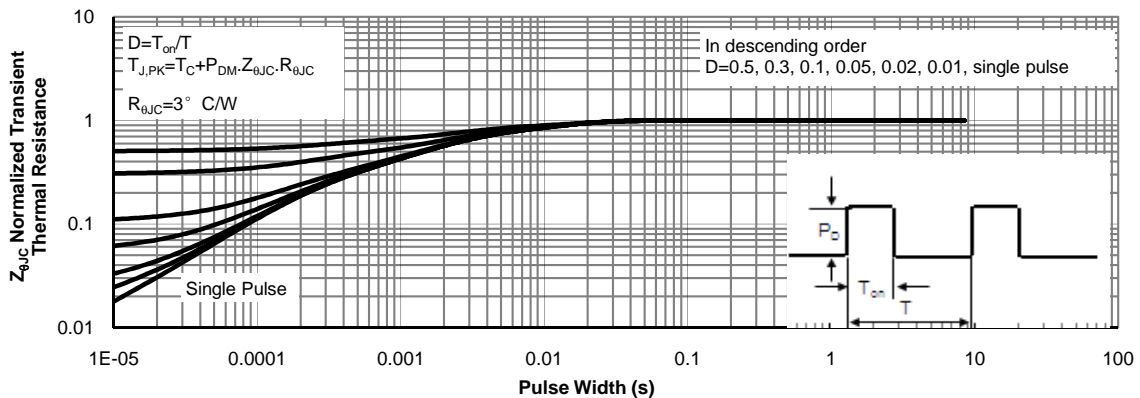
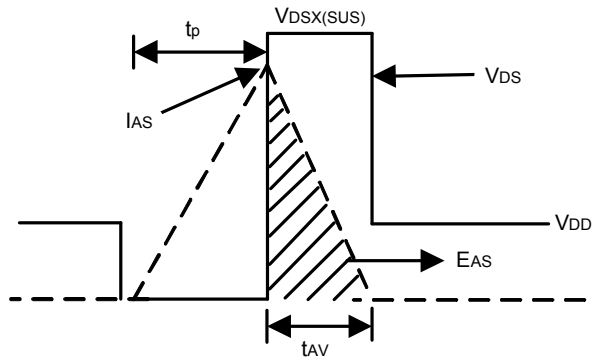
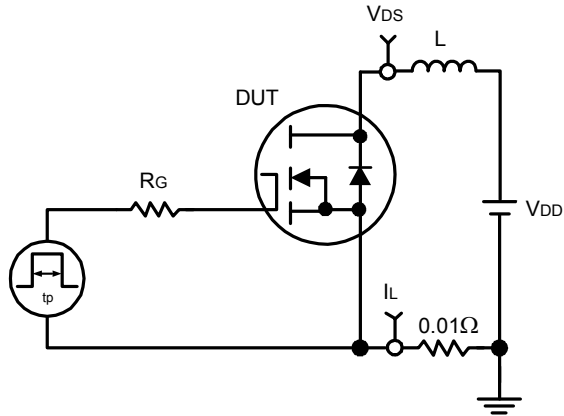
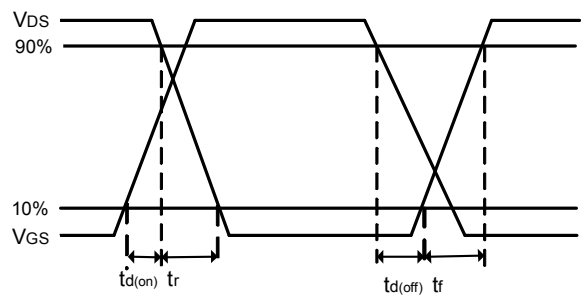
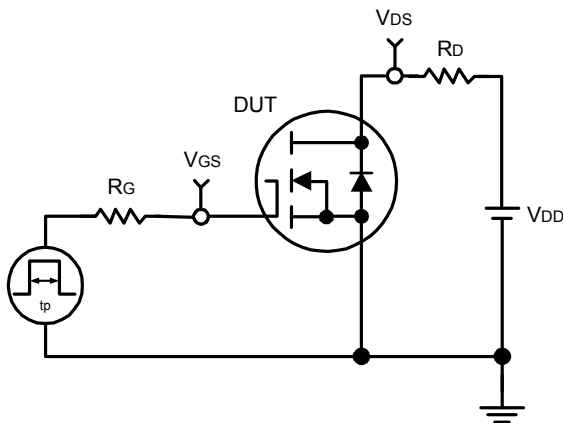

Figure 11: Normalized Maximum Transient Thermal Impedance (Note F)

Avalanche Test Circuit and Waveforms



Switching Time Test Circuit and Waveforms



Package Information: TO-252-3L

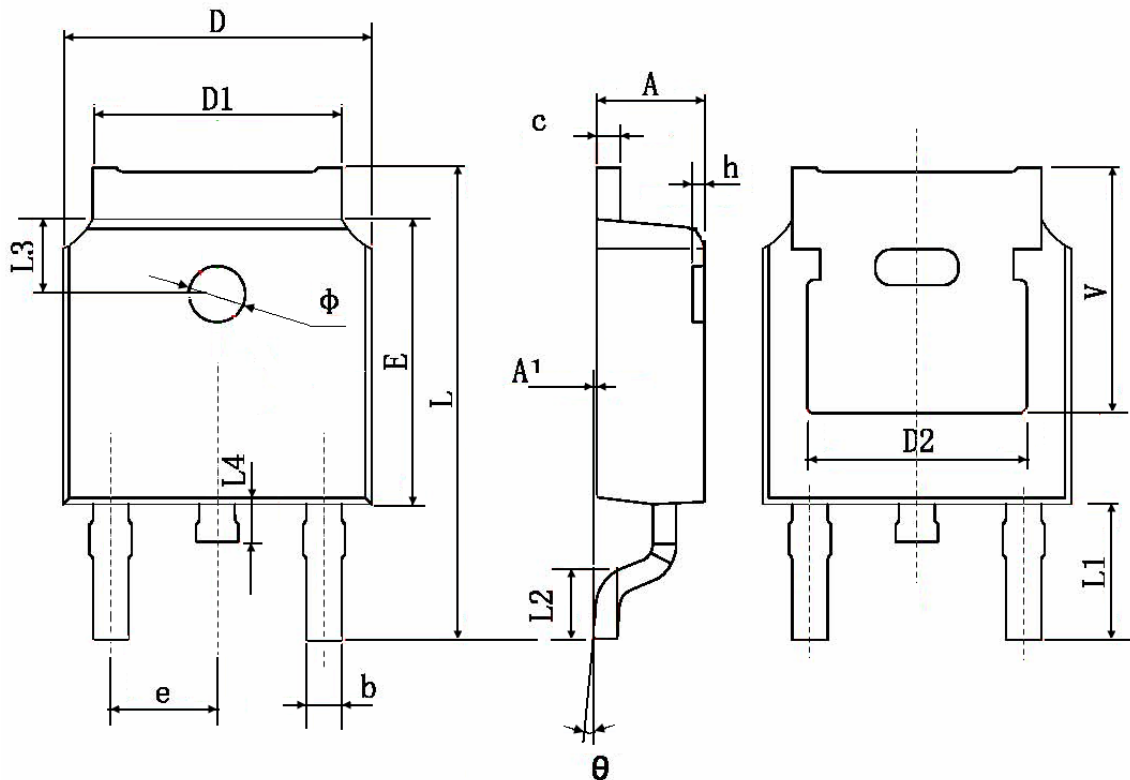

Symbol	Dimensions In Millimeters		Dimensions In Inches	
	Min.	Max.	Min.	Max.
A	2.200	2.400	0.087	0.094
A1	0.000	0.127	0.000	0.005
b	0.660	0.860	0.026	0.034
c	0.460	0.580	0.018	0.023
D	6.500	6.700	0.256	0.264
D1	5.100	5.460	0.201	0.215
D2	4.830 TYP.		0.190 TYP.	
E	6.000	6.200	0.236	0.244
e	2.186	2.386	0.086	0.094
L	9.800	10.400	0.386	0.409
L1	2.900 TYP.		0.114 TYP.	
L2	1.400	1.700	0.055	0.067
L3	1.600 TYP.		0.063 TYP.	
L4	0.600	1.000	0.024	0.039
Φ	1.100	1.300	0.043	0.051
θ	0°	8°	0°	8°
h	0.000	0.300	0.000	0.012
V	5.350 TYP.		0.211 TYP.	