

Jun.1.2023 Copyright 2023 HIROSE ELECTRIC CO., LTD. All Rights Reserved.
In case of consideration for using Automotive equipment / device which demand high reliability, kindly contact our sales window correspondents.

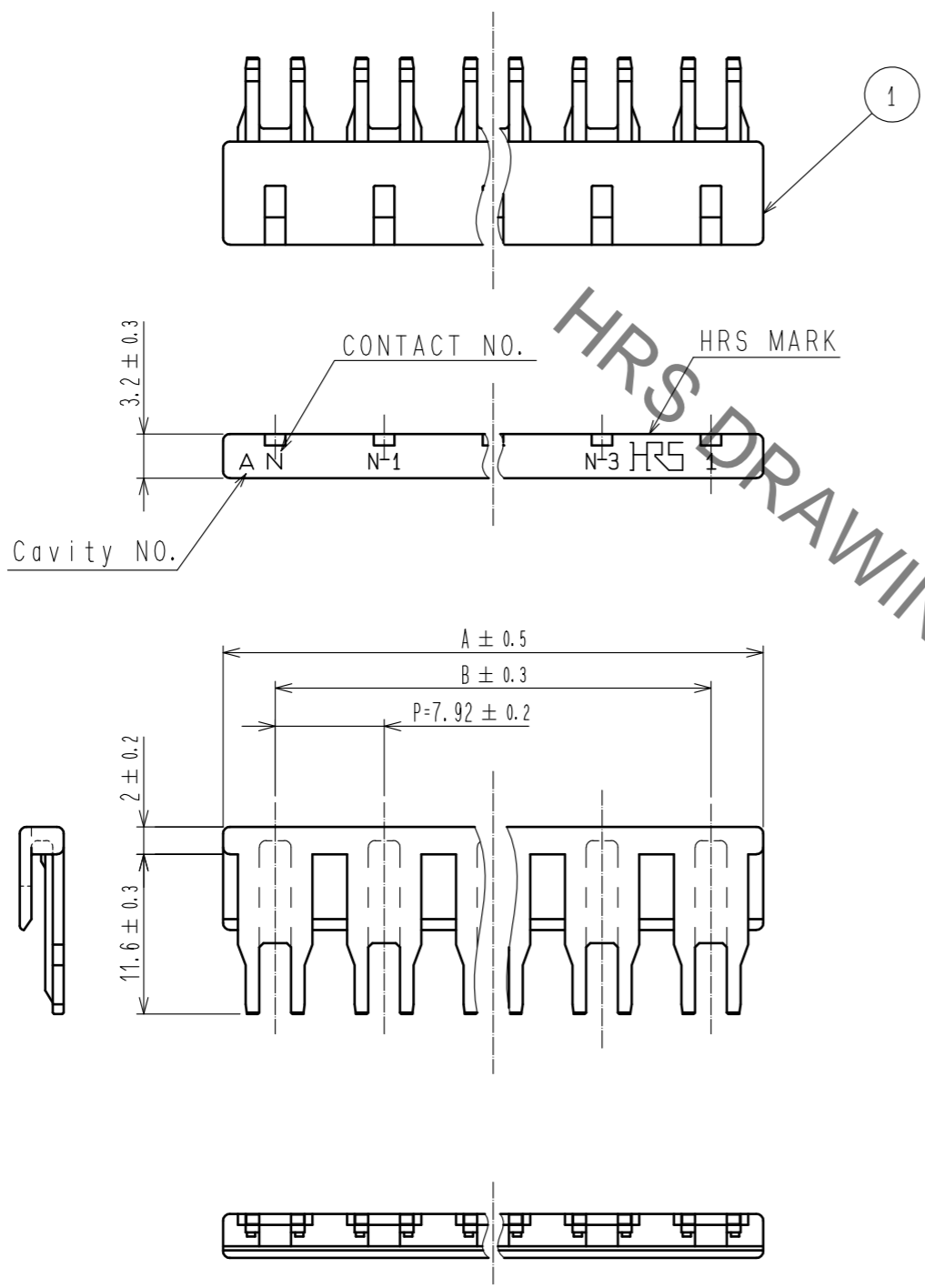

HRS DRAWING FOR REFERENCE

PART No.	CODE No.	NUMBER OF CONTACT	A	B
DF22B/C-2RS/P-7.92	CL680-1200-2-00	2	15.5	7.92
DF22B/C-3RS/P-7.92	CL680-1201-5-00	3	23.42	15.84
DF22B/C-4RS/P-7.92	CL680-1202-8-00	4	31.34	23.76
DF22B/C-5RS/P-7.92	CL680-1203-0-00	5	39.26	31.68

Note 1 : 100 retainers are in one pack.

(Delete)

NO.	MATERIAL	FINISH . REMARKS	NO.	MATERIAL	FINISH . REMARKS		
			1	POLYAMIDE	BLACK, UL94V-0		
UNITS mm		SCALE 2 : 1	COUNT 1	DESCRIPTION OF REVISIONS DIS-H-00012899	DESIGNED TS. KUMAZAWA	CHECKED SZ. ONO	DATE 20220228
HRS HIROSE ELECTRIC CO., LTD.		APPROVED : KI. AKIYAMA 20140918	DRAWING NO. EDC3-164777-01				
		CHECKED : TS. FUKUSHIMA 20140917	PART NO. DF22B/C-*RS/P-7.92				
		DESIGNED : HT. SATO 20140917	CODE NO. CL680-		1/3		
		DRAWN : MI. SAKIMURA 20140912					

Jun.1.2023 Copyright 2023 HIROSE ELECTRIC CO., LTD. All Rights Reserved.
In case of consideration for using Automotive equipment / device which demand high reliability, kindly contact our sales window correspondents.

Precautions

Notification for harness assembly

- 1) When inserting the crimping terminal to the crimping socket, please do not tilt the crimping terminal or twist the cable.
Insertion at tilted angles or twisting the cable may cause deformation of the crimping terminal or crimping socket.
- 2) After inserting the crimping terminal to the crimping socket, please make sure that the lance has been hooked with pulling the cable lightly.
When checking the hook, please avoid bending the cable for preventing terminal drop-off.

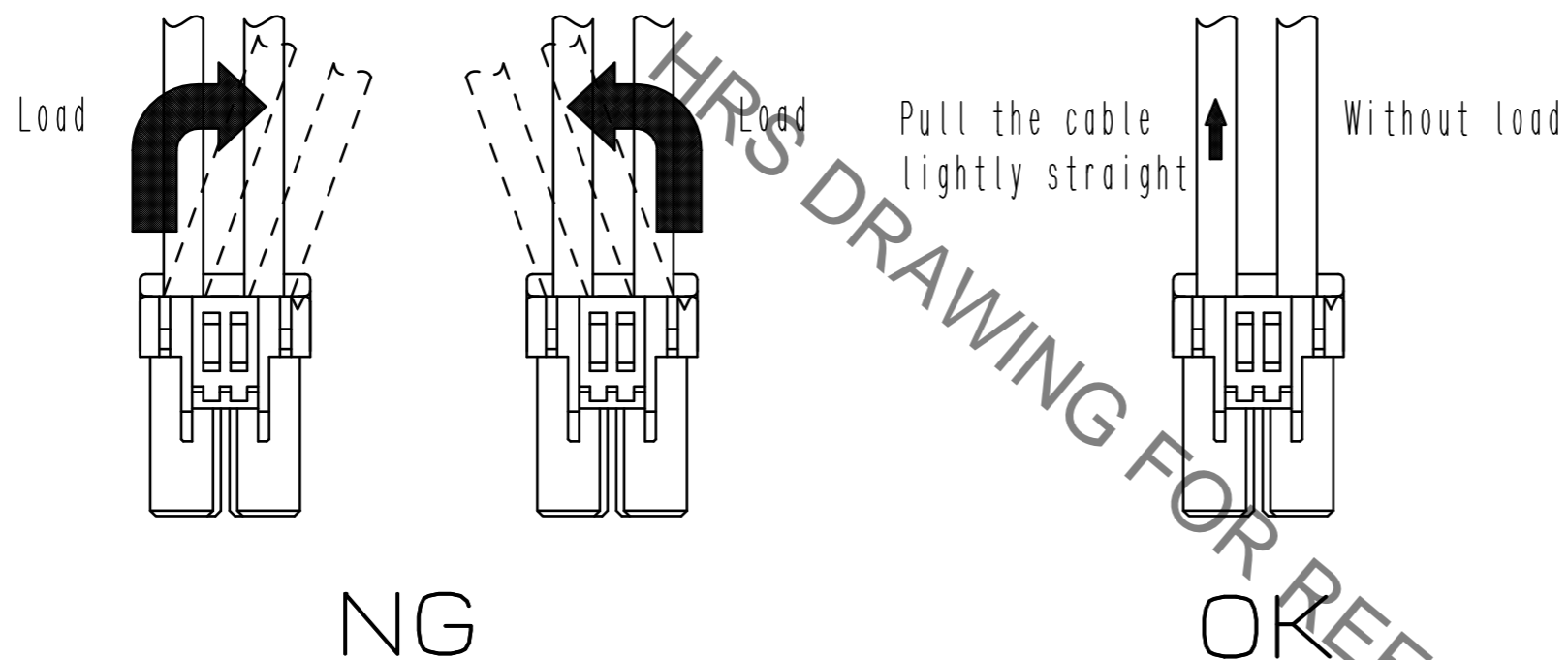

- 3) Bundle cables/Cable Cables
Recommend bundle and strip position of cables are 100 mm or more.
Bundling close to the connectors may cause terminal drop-off, breaking cables and unstable connection.

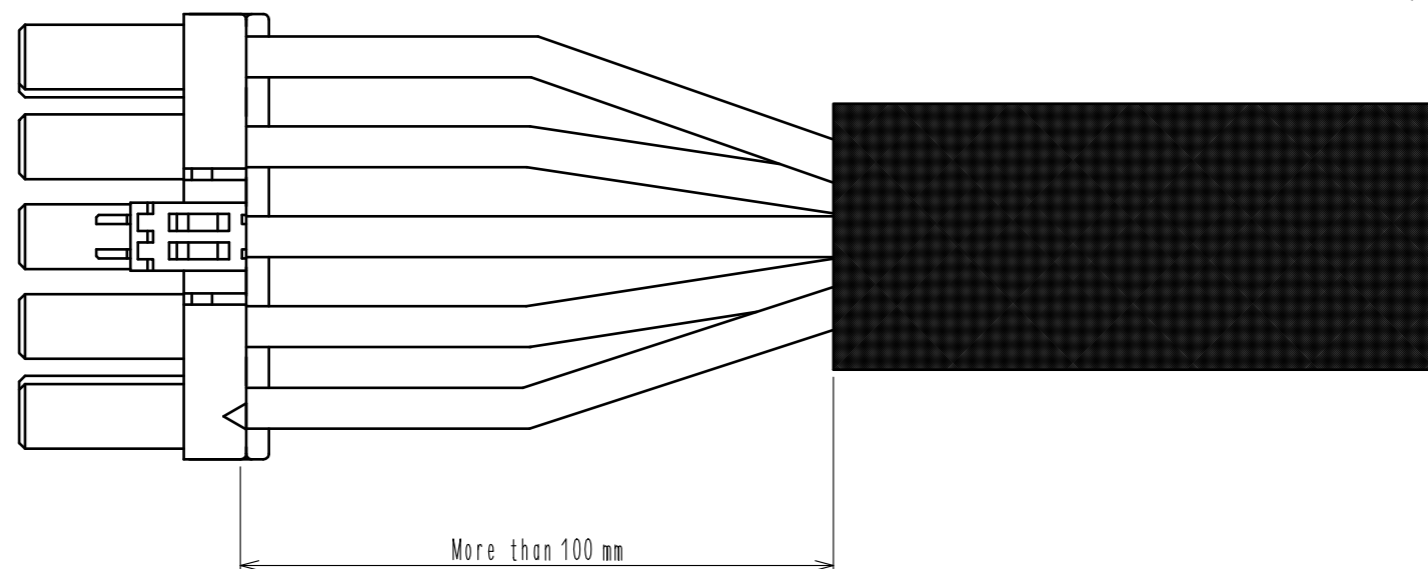

HRS

DRAWING NO.	EDC3-164777-01
PART NO.	DF22B/C-*RS/P-7.92
CODE NO.	CL680-

2/3

Jun.1.2023 Copyright 2023 HIROSE ELECTRIC CO., LTD. All Rights Reserved.
In case of consideration for using Automotive equipment / device which demand high reliability, kindly contact our sales window correspondents.

Precautions

Notification for Insertion/Extraction

1) Please insert/extract the crimping socket straight to the mating connector.
Insertion/Extraction at tilted angles applies load concentration to the connector end and may cause deformation (at connection area, socket and header case, etc). There is a firing risk using this kind of deformed connector.



Insertion/Extraction

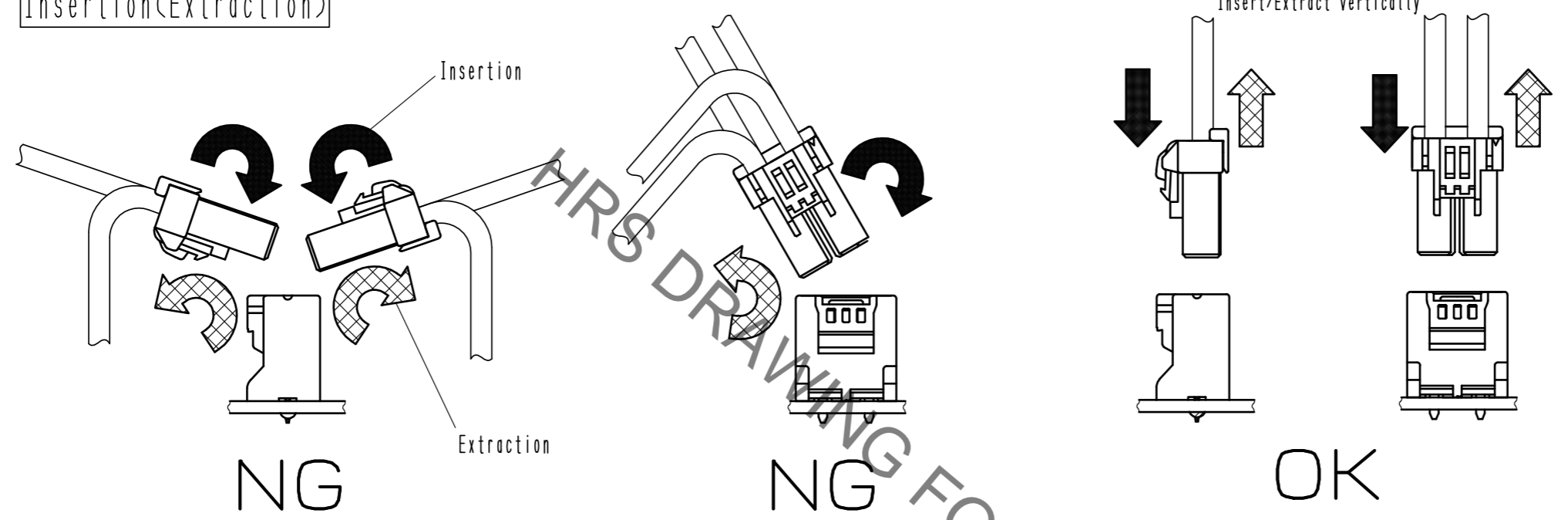

2) When it is hard to extract, please lightly insert the connector beforehand and then pull it with releasing the lock.
Forced extraction has a risk of connector breakage.

Notification of wiring

1) When using a thick cable, short cable length and bending close to the connector end, these load concentrations may cause deformation.
Please note that there is a firing risk using a deformed connector.
When installing, please refrain from stress concentration such as cable bending close to the connector end or cable twisting.

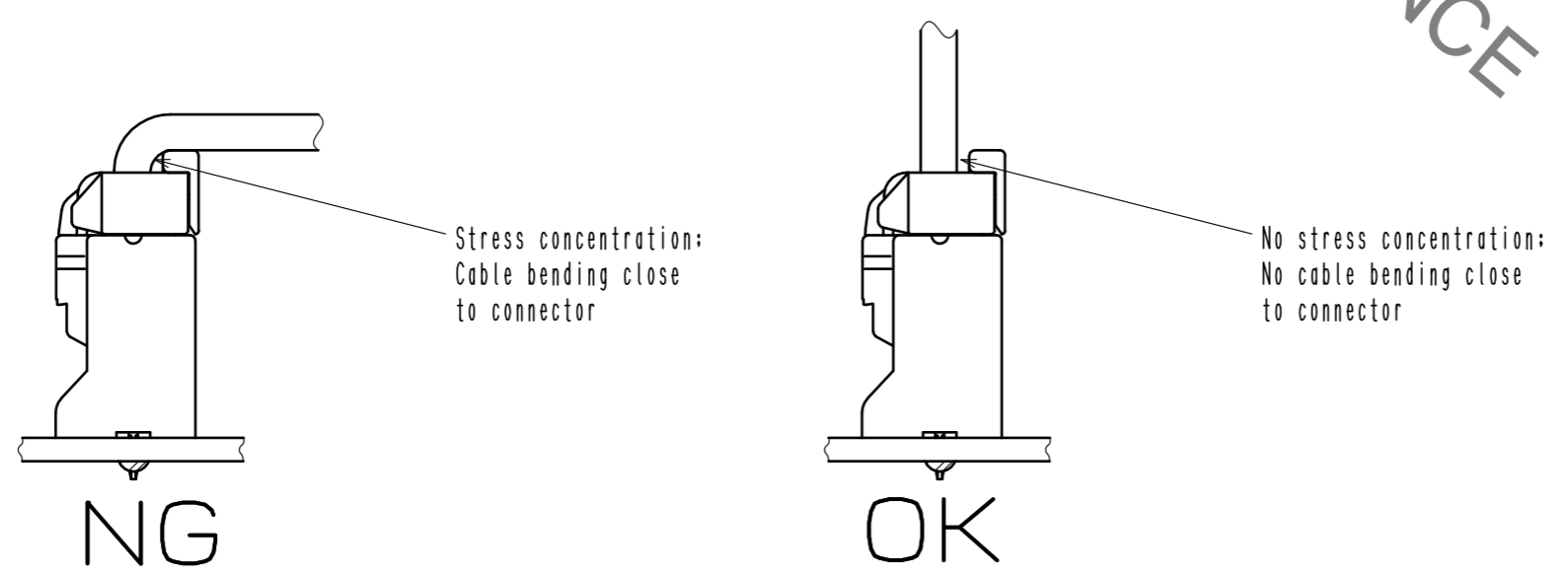

HRS	DRAWING NO.	EDC3-164777-01	
	PART NO.	DF22B/C-*RS/P-7.92	
	CODE NO.	CL680-	3/3