

GENERAL DESCRIPTION

LM2576 Series are step-down switching regulators with all required active functions. It is capable of driving 3A load with excellent line and load regulations. These devices are available in fixed output voltages of 3.3V, 5V and adjustable output version.

LM2576 series operates at a switching frequency of 52kHz thus allowing smaller sized filter components than what would be needed with lower frequency switching regulators. It substantially not only reduces the area of board size but also the size of heat sink, and in some cases no heat sink is required. The $\pm 4\%$ tolerance on output voltage within specified input voltages and output load conditions is guaranteed. Also, the oscillator frequency accuracy is within $\pm 10\%$. External shutdown is included. Featuring 70 μ A (typical) standby current. The output switch includes cycle-by-cycle current limiting, as well as thermal shutdown for full protection under fault conditions.

Features

- Output Voltage: 3.3V, 5V & Adjustable version
- Adjustable Output Voltage Range 1.23V~37V $\pm 4\%$
- 52kHz fixed switching frequency
- Voltage Mode Non-synchronous PWM control
- Thermal Shutdown and Current Limit Protection
- ON/OFF Shutdown Control Input
- High Efficiency
- Short Circuit Protect (SCP)
- Operating Voltage Can be up to 40V
- Output Load Current 3A
- Low Power Standby Mode
- P+ Product Enhancement Tested

Applications

- Simple High-efficiency Step down Regulator
- On-Card Switching Regulators
- Positive to Negative Converter

TYPICAL APPLICATION

OUTPUT VOLTAGE	PART NO.	PACKAGE	PACKING
3.3V	LM2576S-3.3	TO-263-5L(D ² PAK)	500pcs / 13" Reel
5.0V	LM2576S-5.0	TO-263-5L(D ² PAK)	500pcs / 13" Reel
ADJ	LM2576S-ADJ	TO-263-5L(D ² PAK)	500pcs / 13" Reel

Marking:

LM2576S-3.3

	TECH PUBLIC
	LM2576S
-3.3	P+

LM2576S-5.0

	TECH PUBLIC
	LM2576S
-5.0	P+

LM2576S-ADJ

	TECH PUBLIC
	LM2576S
-ADJ	P+

PIN CONFIGURATION

TO-263-5L (D²PAK)

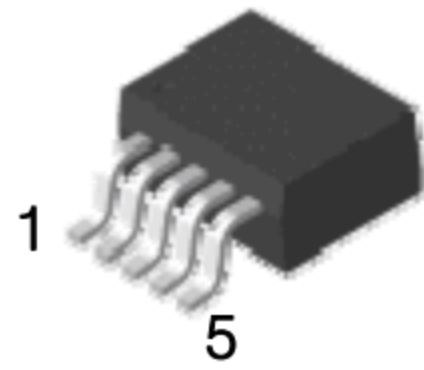

Pin Definition:

1. Input
2. SW Output
3. Ground
4. Feedback
5. Enable

ABSOLUTE MAXIMUM RATINGS

Parameter	Symbol	Limit	Unit
Maximum Supply Voltage	V_{CC}	+45	V
Recommend Operating Supply Voltage	V_{OP}	4.5 to 40	V
SW, EN Pin Input Voltage	V_{SW}, V_{EN}	-0.3 to +25	V
Feedback Pin Voltage	V_{FB}	-0.3 to +25	V
Power Dissipation	P_D	Internally Limited	W
Output Voltage to Ground	V_{OUT}	-1	V
Storage Temperature Range	T_{ST}	-65 to +150	°C
Operating Temperature Range	T_{OP}	-40 to +125	°C
ESD Susceptibility (HBM)		2	kV

THERMAL INFORMATION

Parameter		Symbol	Maximum	Unit
Thermal Resistance (Junction to Case)	TO-263-5L	θ_{JC}	2	°C/W
Thermal Resistance (Junction to Ambient)	TO-263-5L	θ_{JA}	50 (note 2)	°C/W

Electrical Characteristics (T_A=25 C unless otherwise noted)

(T_a = 25°C unless otherwise noted, V_{IN}=12V for 3.3V, 5V, Adjustable version. I_{LOAD}=0.5A)

Parameter		Symbol	Test Condition	Min	Typ	Max	Unit
Output Feedback	ADJ	V _{FB}	4.5V ≤ V _{IN} ≤ 40V 0.2A ≤ I _{LOAD} ≤ 3A	1.180	1.23	1.280	V
Efficiency		η	V _{IN} = 12V, I _{LOAD} = 3A, V _{OUT} = 5V	--	77	--	%
Output Feedback	3.3V	V _{FB}	4.75V ≤ V _{IN} ≤ 40V 0.2A ≤ I _{LOAD} ≤ 3A	3.135	3.3V	3.465	V
Efficiency		η	V _{IN} = 12V, I _{LOAD} = 3A	--	75	--	%
Output Feedback	5V	V _{FB}	7V ≤ V _{IN} ≤ 40V 0.2A ≤ I _{LOAD} ≤ 3A	4.75	5	5.25	V
Efficiency		η	V _{IN} = 12V, I _{LOAD} = 3A	--	77	--	%
Feedback Bias Current		I _{FB}	V _{OUT} = 5V (Adjustable Version)	--	50	100	nA
Oscillator Frequency		F _{OSC}		47	52	58	KHz
Soft-Start Time		T _{SS}	Rising edge of EN on to I _{CL}	--	3	--	mS
Current Limit		I _{CL}	Peak Current, no outside circuit V _{FB} = 0V force driver on	5.9	--	--	A
Saturation Voltage		V _{SAT}	I _{OUT} = 3A, No outside circuit V _{FB} = 0V force driver on	--	1.4	1.8	V
ON/OFF Pin Logic Input Threshold Voltage		V _{IL}	Low (regulator ON)	--	1.2	1.0	V
		V _{IH}	High (regulator OFF)	2.2	1.4	--	
ON/OFF Pin Logic Input Current		I _L	V _{LOGIC} = 5V (OFF)	--	12	30	μA
		I _H	V _{LOGIC} = 0V (ON)	--	0	10	
Maximum Duty Cycle (ON)		DC	V _{FB} = 0V force driver on	93	98	--	%
Maximum Duty Cycle (OFF)			V _{FB} = 12V force driver off	--	0	--	
Quiescent Current		I _Q	V _{FB} = 12V force driver off	--	5	10	mA
Standby Quiescent Current		I _{STBY}	ON/OFF pin = 5V	--	70	200	μA
			V _{IN} = 40V	--		250	
SW Pin Leakage Current	SW pin = 0	I _{SWL}	No outside circuit, V _{FB} = 12V force driver off	--	0.3	2	mA
	SW pin = -1		V _{IN} = 12V	--	7.5	30	mA

BLOCK DIAGRAM

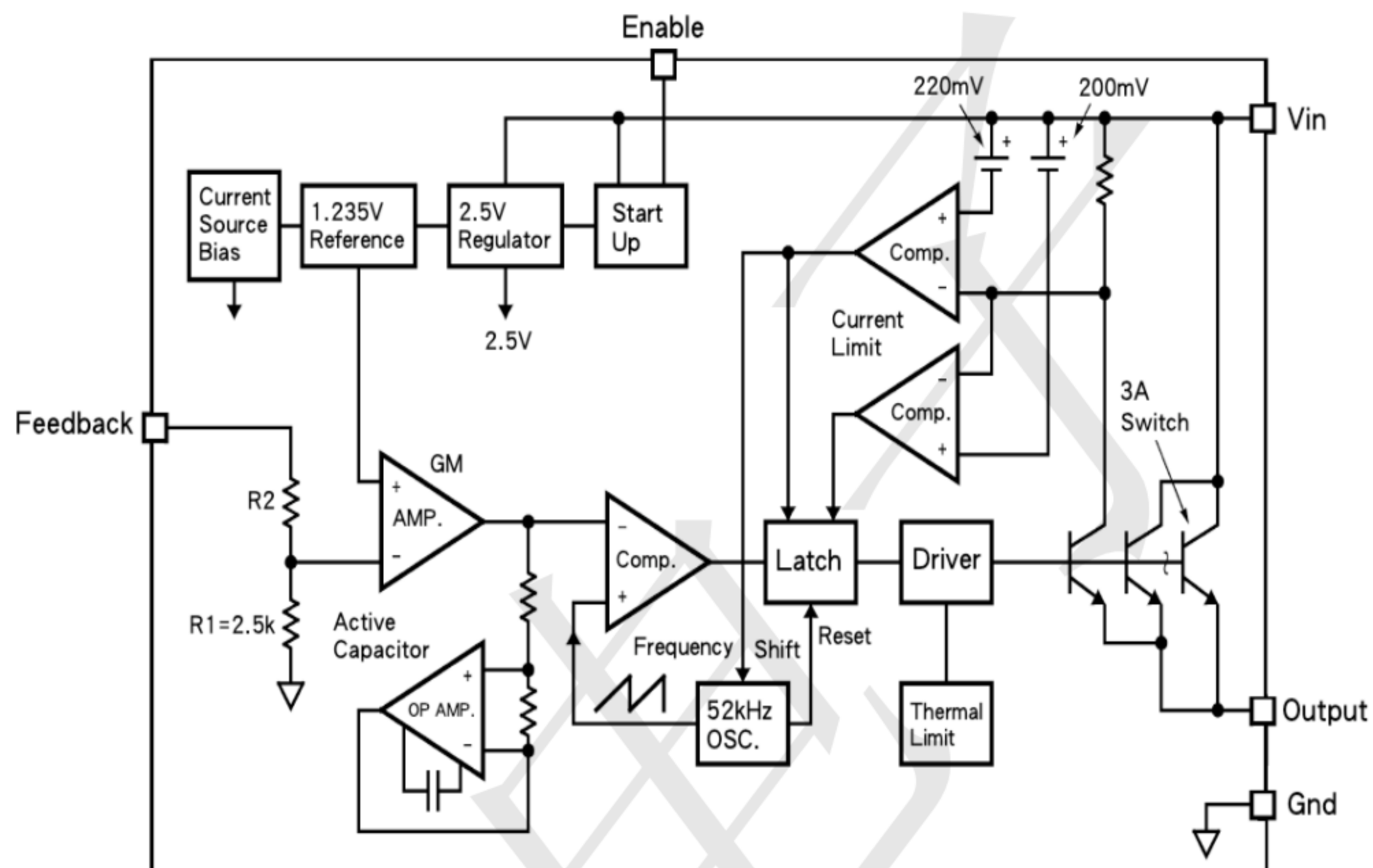

TYPICAL APPLICATION CIRCUIT

1. Adjustable Output Voltage Version

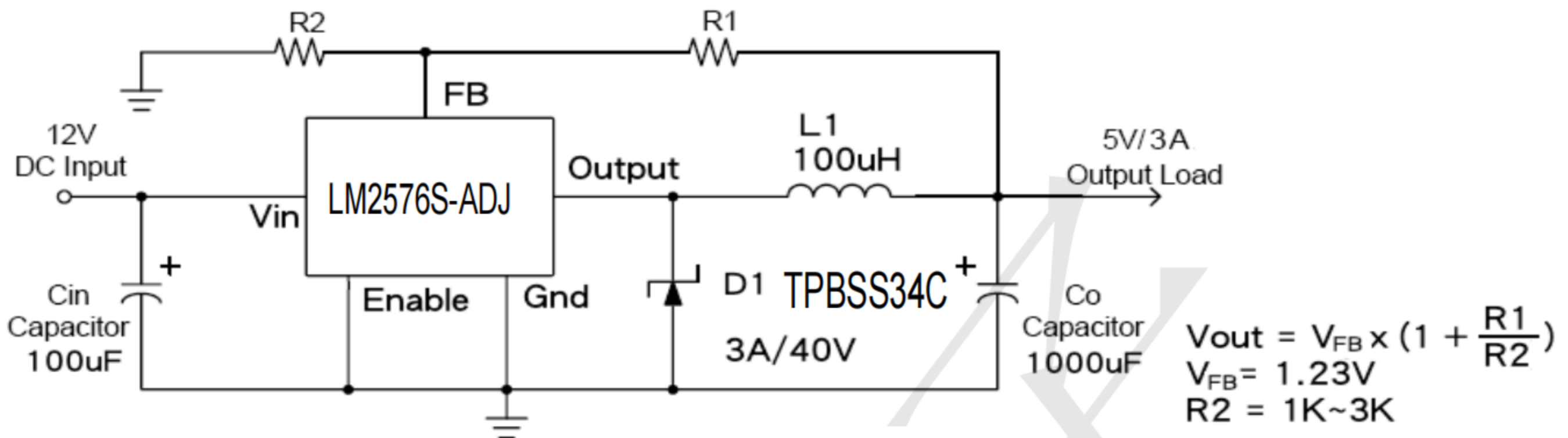

2. Fixed Output Voltage Version

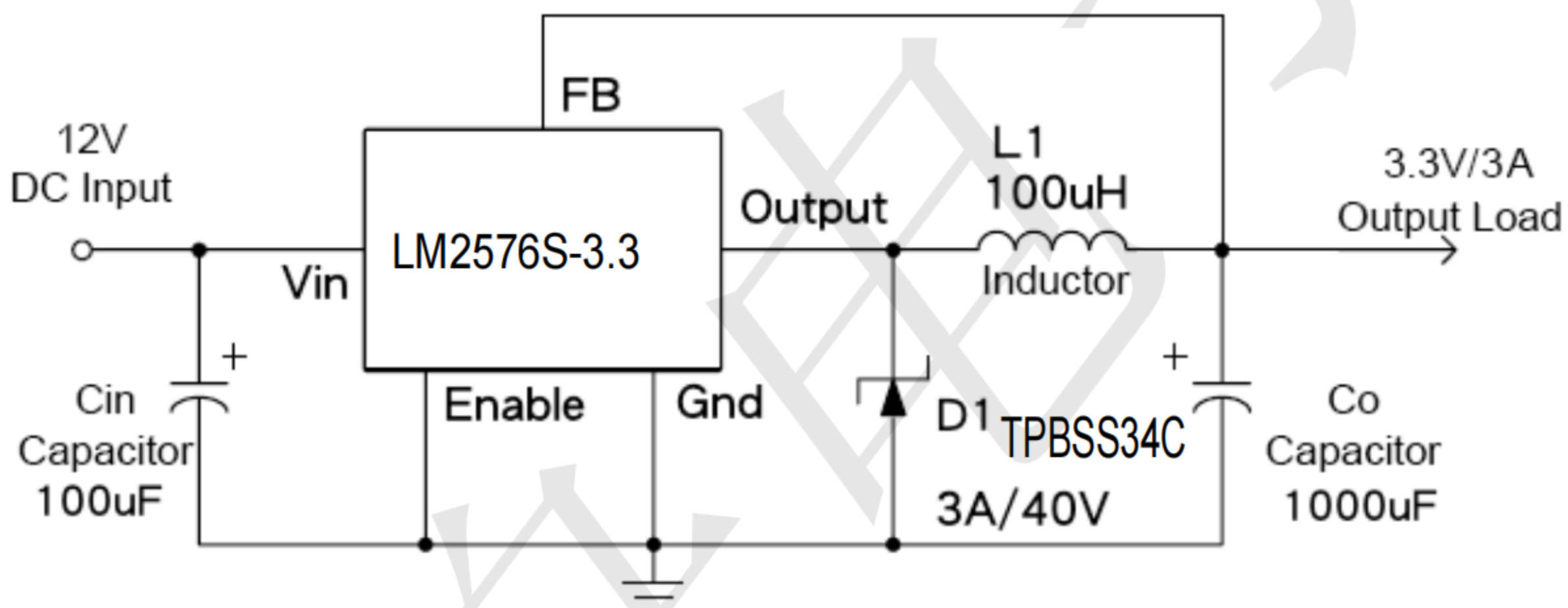

3. Adjustable Output Voltage Version with Delayed Startup

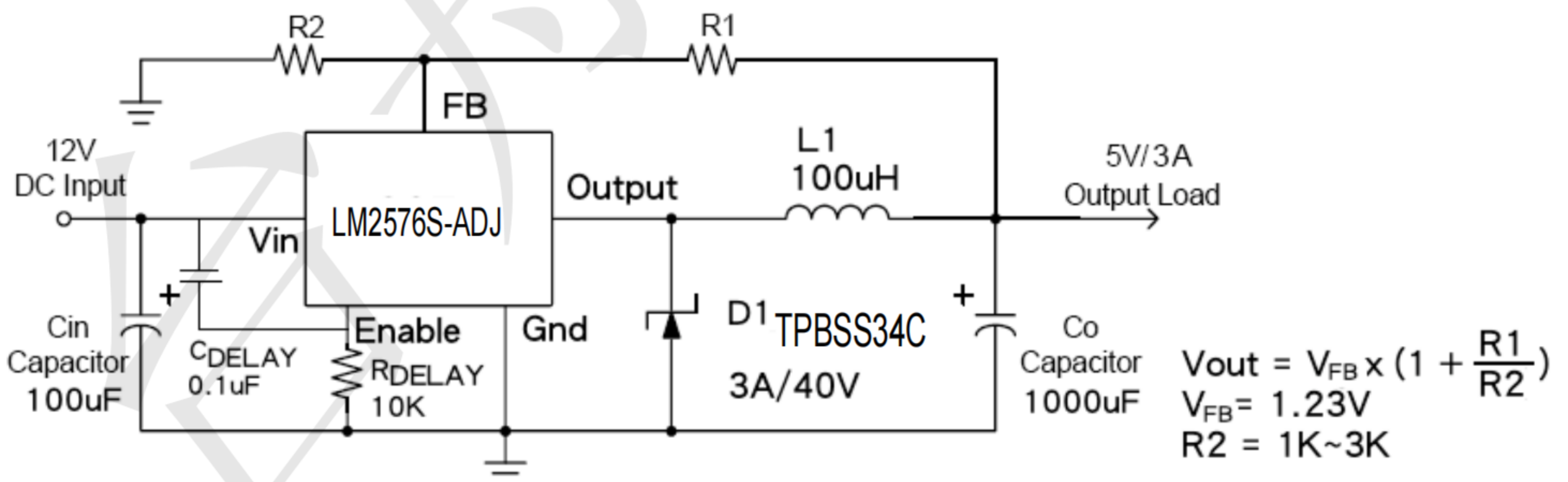

PACKAGE OUTLINE DIMENSIONS (Unit: Millimeters)

TO-263-5L (D²PAK)

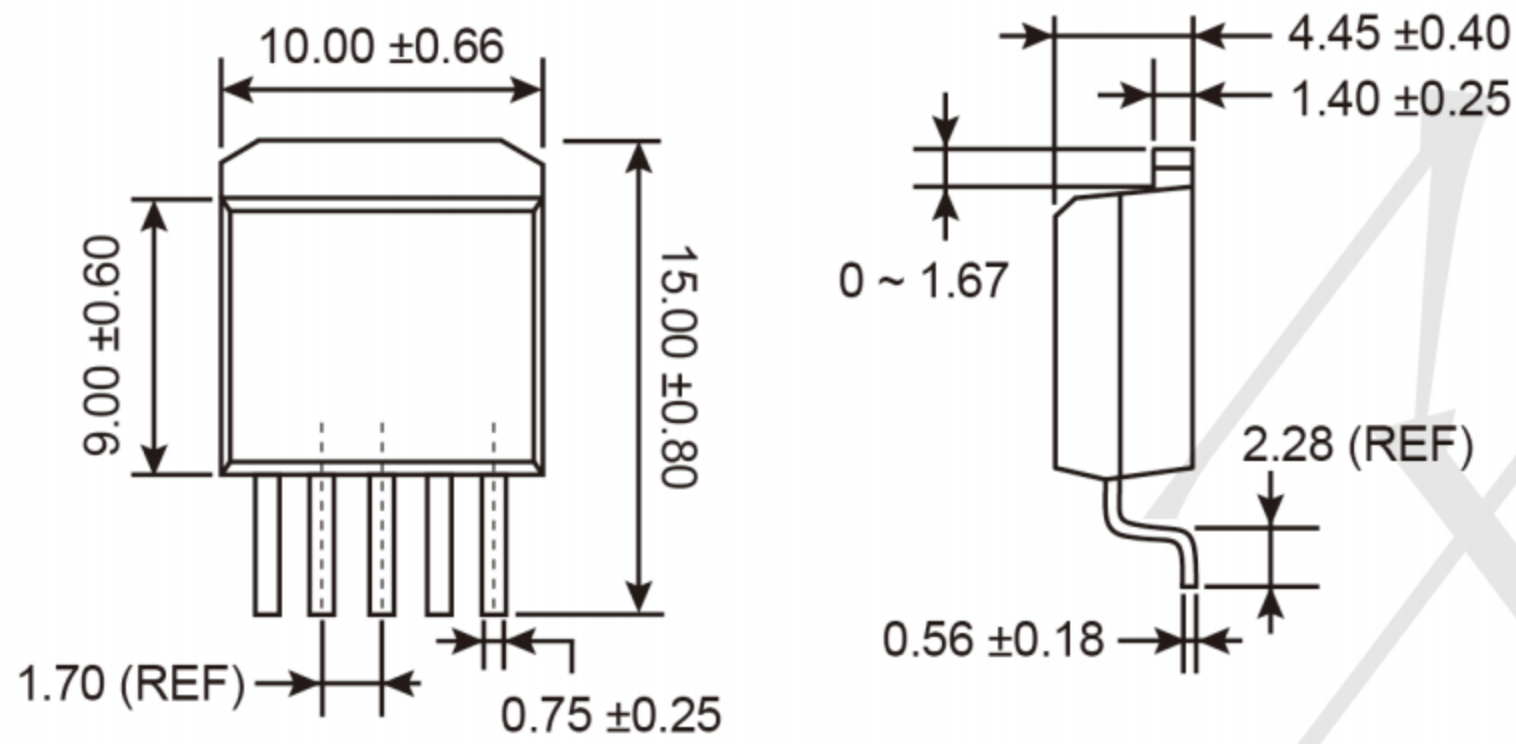

SUGGESTED PAD LAYOUT (Unit: Millimeters)

