

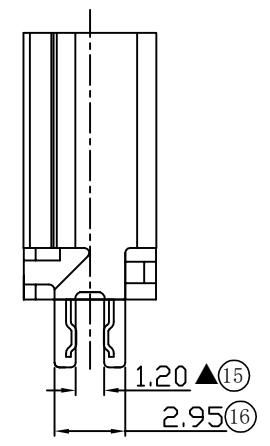

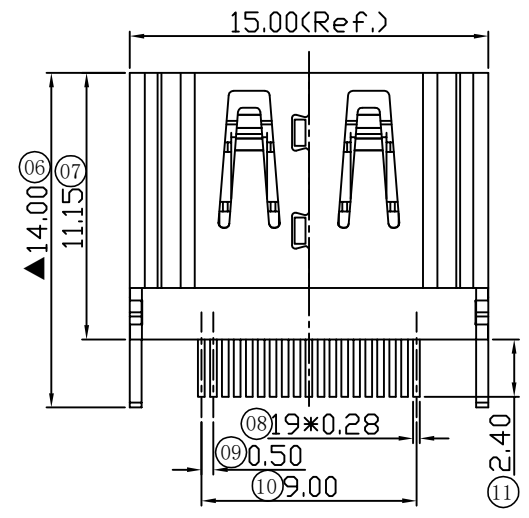

修订	标记	修改摘要	签名	日期
REV	MARK	REVISION DESCRIPTION	SIGNATURE	DATE
AO		NEW DWG		2016-03-12

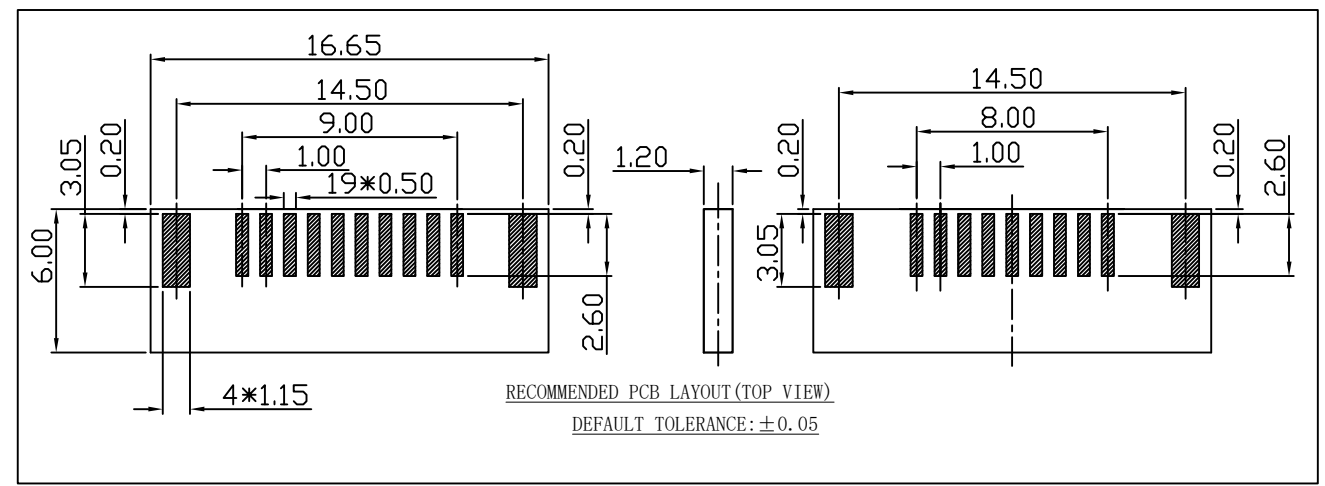
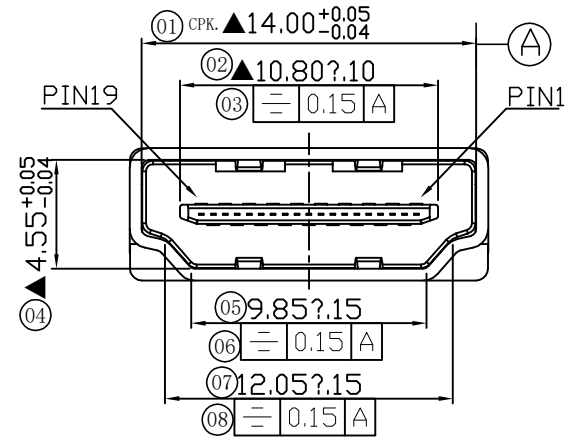

SPECIFICATION

- Electrical characteristics
 - Contact Current Rating: 0.5 A
 - Dielectric Withstanding Voltage: 300V AC
 - Insulation Resistance: a. Mate 100M Ω MIN at 500V/DC
 - b. Unmate 10M Ω MIN at 150V/DC
 - Contact Resistance: 30m Ω MAX
 - Temperature Range: -20 $^{\circ}$ C to +85 $^{\circ}$ C
- Mechanical
 - Mating Face: 44.1N MAX
 - Unmating Face: 9.8N MIN; 39.2N MAX
 - Durability: 5000 Cycles
- Material:
 - HOUSING: THERMOPLASTICS HIGH TEMP LCP+GLASS
 - FIBER BLACK COLOR, UL94V-0
 - CONTACT: Copper Alloy, T=0.20MM
 - SHELL: Copper Alloy (SPCC), T=0.50MM
- PLATING:
 - CONTACT: 1~30 μ " GOLD/TIN PLATING ON CONTACT AREA
 - 100 μ " MIN, TIN PLATING ON SOLDER TAILS
 - 50 μ " MIN, NICKEL UNDERPLATING OVER ALL
 - SHELL: 80 μ " NICKEL UNDERPLATING OVER ALL

		深圳市华德共创科技有限公司 Shenzhen Huade co-create Technology Co., LTD 电话: 0755-23304126 传真: 0755-29940187				
-TOLERANCES- UNLESS OTHERWISE SPECIFIED 公差参数表		 	TITLE: HDMI AF夹板1.2铜壳0.5镀金 产品名称: 黑胶弯端			
X.X ± 0.30	X.X* $\pm 3^{\circ}$	APPD: 核准:	PART NO: 产品编号: HDMI-GD-130PWB			
X.XX ± 0.20	X.XX* $\pm 2^{\circ}$	CHECK: 校对: 王建业	DATE	SCALE	UNIT	CODE NUMBER
X.XXX ± 0.10	X.XXX* $\pm 1^{\circ}$	DRAW: 绘图: 黄艳兰	2016-03-12	1:1	mm	A001