

REV NO	MARK	修改摘要 REVISION DESCRIPTION	签名 SIGNATURE	日期 DATE
		NEW DWG		2016-03-12

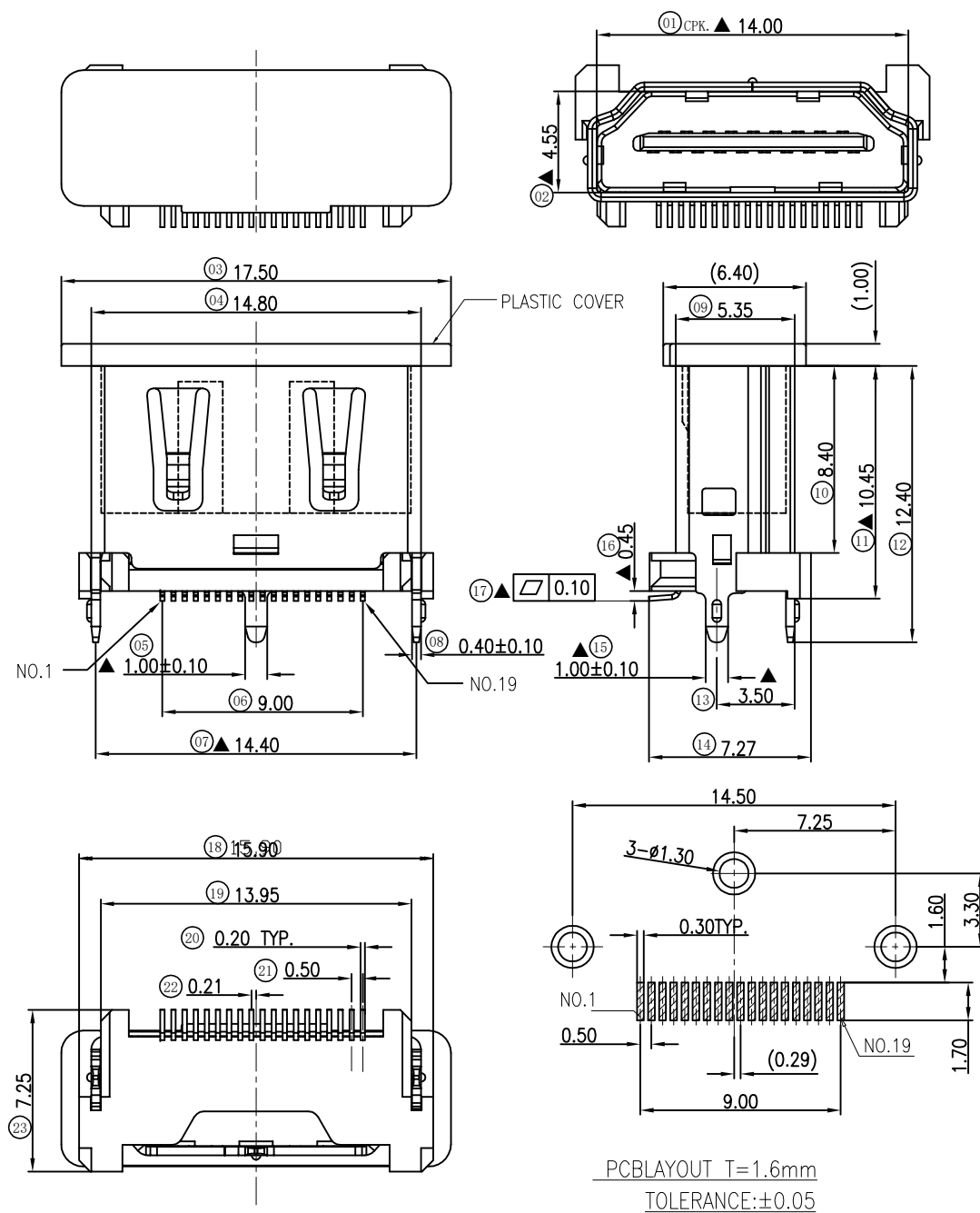

**NOTE:**

- MATERIALS AND FINISHED**  
 INSULATOR : LCP UL-94V0,  
 COVER:LCP UL-94V0  
 SHELL : C2680, NI FINISHED  
 CONTACT MATERIAL :C5191 GOLD FINISHED
- ELECTRICAL CHARACTERISTICS**  
 CONTACT CURRENT RATING : 0.5 AMPS  
 CONTACT RESISTANCE :20 MILLIOHMS MAX.  
 DIELECTRIC WITHSTANDING VOLTAGE : 500 V AC MIN.  
 INSULATION RESISTANCE : 100 MEGAOHMS MIN.
- MECHANICAL**  
 MATING FORCE:4.5Kgf MAX.  
 UNMATING FORCE:1.0 Kgf MIN
- ENVIRONMENTAL**  
 TEMPERATURE RATING : -55°C ~ +105°C

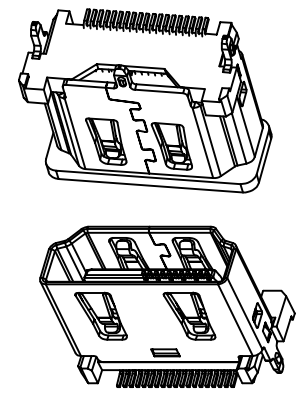

		深圳市华德共创科技有限公司 Shenzhen Huade co-create Technology Co.,LTD 电话: 0755-23304126 传真: 0755-29940187						
-TOLERANCES- UNLESS OTHERWISE SPECIFIED 公差参数表				TITLE: HDMI 立式母座10.5高 铜壳 产品名称: 镀镍黑胶				
X.X	±0.30	X.X*	±3°	APPD: 核准:	PART NO: 产品编号: HDMI-GD-117PWB			
X.XX	±0.20	X.XX*	±2°	CHECK: 校对: 王建业	DATE	SCALE	UNIT	CODE NUMBER
X.XXX	±0.10	X.XXX*	±1°	DRAW: 绘图: 黄艳兰	2016-03-12	1:1	mm	A001