

修 订 REV NO	标 记 MARK	修 改 描 要 REVISION DESCRIPTION	签 名 SIGNATURE	日 期 DATE
		NEW DWG		2016-03-12

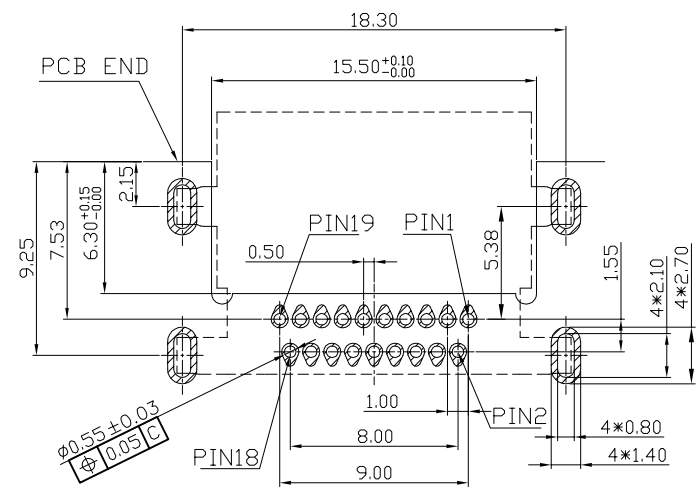

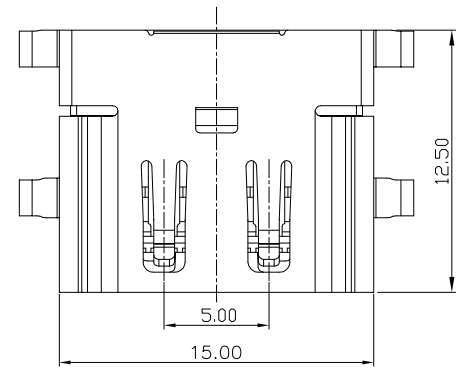

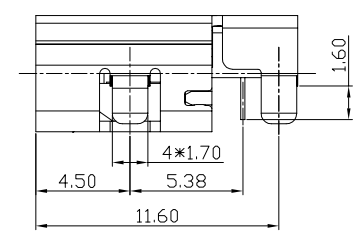
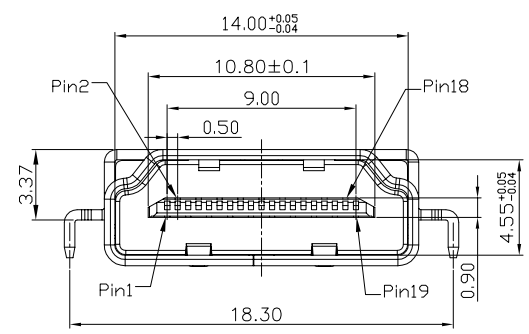

$\phi 0.55 \pm 0.03$   
 $\phi 0.05 C$

RECOMMENDED PCB LAYOUT T=1.60  
 GENERAL TOLERANCES: ±0.05(TOP VIEW)

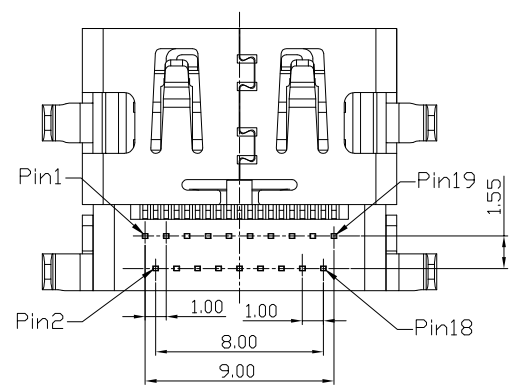

- NOTES:
- ELECTRONIC:
    - CONTACT CURRENT RATING: 0.5A
    - CONTACT RESISTANCE: 30mohm Max
    - INSULATION RESISTANCE: 100 Megohms Min
    - WITHSTAND VOLTAGE: AC 500V,1Min.
  - MECHANICAL:
    - MATING FORCE: 44.1N Max
    - UNMATED FORCE: 9.8N~39.2N Max
    - DURABILITY: 10000 CYCLES
  - ENVIRONMENT CHARACTERISTICS:
    - OPERATING TEMPERATURE: -25°C TO +85°C



 <b>深圳市华德共创科技有限公司</b> Shenzhen Huade co-create Technology Co.,LTD 电话: 0755-23304126 传真: 0755-29940187								
-TOLERANCES- UNLESS OTHERWISE SPECIFIED 公差参数表		 		TITLE: HDMI AF反向沉板不锈钢镀镍 产品名称: 黑胶3.37				
X.X	±0.30	X.X*	±3°	APPD: 核准:	PART NO: 产品编号: HDMI-GD-115PWB			
X.XX	±0.20	X.XX*	±2°	CHECK: 校对: 王建业	DATE	SCALE	UNIT	CODE NUMBER
X.XXX	±0.10	X.XXX*	±1°	DRAW: 绘图: 黄艳兰	2016-03-12	1:1	mm	A001