

OV02B 2-megapixel product brief



12" Wafer-Based 2 Megapixel Image Sensor for Entry Level and Mainstream Mobile Cameras



available in a lead-free package

OmniVision's OV02B is the latest member of its 2 megapixel (MP) image sensor family. The OmniPixel[®]3-HS architecture provides this sensor with a 1.75 micron pixel pitch in a 1/5" optical format. The OV02B is built on 12" wafers while maintaining a die size that is comparable to our existing 2MP sensors, offering an effective alternative to 8" wafer-based sensors for cost sensitive entry level and mainstream smartphones.

Building on the success of its predecessor, the OV02A, while maintaining the same cost, the OV02B has an added SCCB ID (SID) pin, which provides two available hardware I2C addresses to meet the requirements of multicamera applications. It also adds a hardware strobe pin to sync LED flash photography, along with

32 bytes of on-chip OTP memory for storing automatic white balance (AWB) and manufacturer production information. Using a Bayer pattern, it supports both color and monochrome, while also providing a chief ray angle (CRA) of up to 30.69°.

The OV02B is designed for the main and front-facing bokeh cameras in entry level and mainstream smartphones where 2MP has become the industry standard. It also provides a cost-effective solution for the main tablet and notebook cameras. Output formats include 1600 x 1200 at 30 frames per second (fps) and 800 x 600 at 60 fps.

Find out more at www.ovt.com.



Applications

- Mobile Phone Cameras
- Tablet Cameras
- Notebook Cameras
- PC Cameras
- Web Cameras
- Toys

Product Features

- programmable controls:
 - frame rate
 - mirror and flip
 - cropping
 - windowing
- 32 bytes of embedded one-time programmable (OTP) memory
- supports 2x2 mono binning function
- support for output formats: 10-bit/8-bit RAW
- two-wire serial bus control (SCCB)
- supports multi-camera synchronous function
- supports MIPI serial output interface (1-lane)
- support for image sizes:
 - 1600 x 1200 @ 30 fps
 - 800 x 600 @ 60 fps
- supports automatic black level calibration
- supports strobe function

OV02B

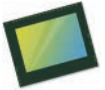

Ordering Information

- **OV02B10-GA5A-001A**
(color, good die with 150 μ m backgrounding, engineering sample)
- **OV02B10-A25A-001A**
(color, lead-free)
25-pin CSP engineering sample
- **OV02B1B-GA5A-001A**
(b&w, good die with 150 μ m backgrounding, engineering sample)
- **OV02B1B-A25A-001A**
(b&w, lead-free)
25-pin CSP engineering sample

Technical Specifications

- **active array size:** 1600 x 1200
- **maximum image transfer rate:**
 - UXGA (1600x1200): 30 fps
 - SVGA (800x600): 60 fps
- **power supply:**
 - analog: 2.7 - 3.0V
 - I/O: 1.7 - 3.0V
- **power requirements:**
 - active: 100 mW
 - standby: <50 μ A
- **temperature range:**
 - operating: -30°C to +85°C junction temperature
 - stable: 0°C to +60°C junction temperature
- **output interfaces:** MIPI 1-lane
- **output formats:** RAW8 and RAW10
- **lens size:** 1/5"
- **lens chief ray angle:** 30.69° non-linear
- **shutter:** rolling shutter
- **pixel size:** 1.75 μ m x 1.75 μ m
- **image area:** 2814 μ m x 2114 μ m

Functional Block Diagram

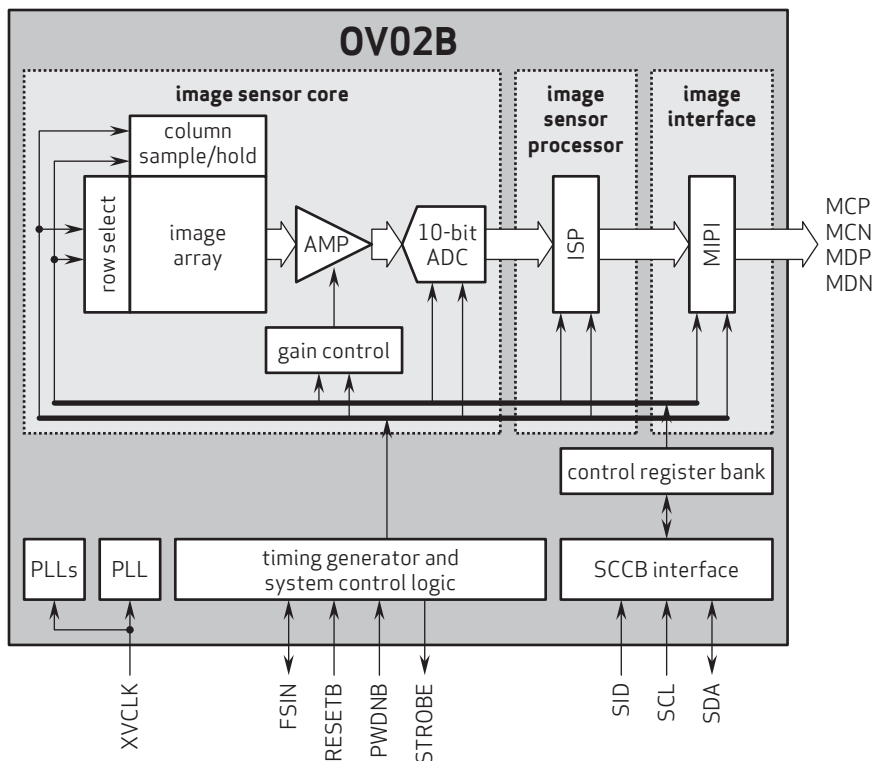

4275 Burton Drive
Santa Clara, CA 95054
USA

Tel: +1 408 567 3000
Fax: +1 408 567 3001
www.ovt.com

OmniVision reserves the right to make changes to their products or to discontinue any product or service without further notice. OmniVision, the OmniVision logo and OmniPixel are registered trademarks of OmniVision Technologies, Inc. All other trademarks are the property of their respective owners.



OmniVision