



Please note that Cypress is an Infineon Technologies Company.

The document following this cover page is marked as “Cypress” document as this is the company that originally developed the product. Please note that Infineon will continue to offer the product to new and existing customers as part of the Infineon product portfolio.

Continuity of document content

The fact that Infineon offers the following product as part of the Infineon product portfolio does not lead to any changes to this document. Future revisions will occur when appropriate, and any changes will be set out on the document history page.

Continuity of ordering part numbers

Infineon continues to support existing part numbers. Please continue to use the ordering part numbers listed in the datasheet for ordering.



CY96F6A6R

F²MC-16FX CY966A0 Series 16-bit Proprietary Microcontroller

CY966A0 series is based on Cypress's advanced F²MC-16FX architecture (16-bit with instruction pipeline for RISC-like performance). The CPU uses the same instruction set as the established F²MC-16LX family thus allowing for easy migration of F²MC-16LX Software to the new F²MC-16FX products. F²MC-16FX product improvements compared to the previous generation include significantly improved performance - even at the same operation frequency, reduced power consumption and faster start-up time. For high processing speed at optimized power consumption an internal PLL can be selected to supply the CPU with up to 32MHz operation frequency from an external 4MHz to 8MHz resonator. The result is a minimum instruction cycle time of 31.2ns going together with excellent EMI behavior. The emitted power is minimized by the on-chip voltage regulator that reduces the internal CPU voltage. A flexible clock tree allows selecting suitable operation frequencies for peripheral resources independent of the CPU speed.

Features

Technology

0.18μm CMOS

CPU

- F²MC-16FX CPU
- Optimized instruction set for controller applications (bit, byte, word and long-word data types, 23 different addressing modes, barrel shift, variety of pointers)
- 8-byte instruction queue
- Signed multiply (16-bit × 16-bit) and divide (32-bit/16-bit) instructions available

System Clock

- On-chip PLL clock multiplier (×1 to ×8, ×1 when PLL stop)
- 4MHz to 8MHz crystal oscillator (maximum frequency when using ceramic resonator depends on Q-factor)
- Up to 8MHz external clock for devices with fast clock input feature
- 32.768kHz subsystem quartz clock
- 100kHz/2MHz internal RC clock for quick and safe startup, clock stop detection function, watchdog
- Clock source selectable from mainclock oscillator, subclock oscillator and on-chip RC oscillator, independently for CPU and 2 clock domains of peripherals
- The subclock oscillator is enabled by the Boot ROM program controlled by a configuration marker after a Power or External reset
- Low Power Consumption - 13 operating modes (different Run, Sleep, Timer, Stop modes)

On-Chip Voltage Regulator

Internal voltage regulator supports a wide MCU supply voltage range (Min=2.7V), offering low power consumption

Low Voltage Detection Function

Reset is generated when supply voltage falls below programmable reference voltage

Code Security

Protects Flash Memory content from unintended read-out

DMA

Automatic transfer function independent of CPU, can be assigned freely to resources

Interrupts

- Fast Interrupt processing
- 8 programmable priority levels
- Non-Maskable Interrupt (NMI)

CAN

- Supports CAN protocol version 2.0 part A and B
- ISO16845 certified
- Bit rates up to 1Mbps
- 32 message objects
- Each message object has its own identifier mask
- Programmable FIFO mode (concatenation of message objects)
- Maskable interrupt
- Disabled Automatic Retransmission mode for Time Triggered CAN applications
- Programmable loop-back mode for self-test operation

USART

- Full duplex USARTs (SCI/LIN)

- Wide range of baud rate settings using a dedicated reload timer
- Special synchronous options for adapting to different synchronous serial protocols
- LIN functionality working either as master or slave LIN device
- Extended support for LIN-Protocol to reduce interrupt load

I²C

- Up to 400kbps
- Master and Slave functionality, 7-bit and 10-bit addressing

A/D Converter

- SAR-type
- 8/10-bit resolution
- Signals interrupt on conversion end, single conversion mode, continuous conversion mode, stop conversion mode, activation by software, external trigger, reload timers and PPGs
- Range Comparator Function
- Scan Disable Function
- ADC Pulse Detection Function

Source Clock Timers

Three independent clock timers (23-bit RC clock timer, 23-bit Main clock timer, 17-bit Sub clock timer)

Hardware Watchdog Timer

- Hardware watchdog timer is active after reset
- Window function of Watchdog Timer is used to select the lower window limit of the watchdog interval

Reload Timers

- 16-bit wide
- Prescaler with $1/2^1$, $1/2^2$, $1/2^3$, $1/2^4$, $1/2^5$, $1/2^6$ of peripheral clock frequency
- Event count function

Free-Running Timers

- Signals an interrupt on overflow, supports timer clear upon match with Output Compare (0, 4)
- Prescaler with 1, $1/2^1$, $1/2^2$, $1/2^3$, $1/2^4$, $1/2^5$, $1/2^6$, $1/2^7$, $1/2^8$ of peripheral clock frequency

Input Capture Units

- 16-bit wide
- Signals an interrupt upon external event
- Rising edge, Falling edge or Both (rising & falling) edges sensitive

Output Compare Units

- 16-bit wide
- Signals an interrupt when a match with Free-running Timer occurs
- A pair of compare registers can be used to generate an output signal

Programmable Pulse Generator

- 16-bit down counter, cycle and duty setting registers
- Can be used as 2×8 -bit PPG
- Interrupt at trigger, counter borrow and/or duty match
- PWM operation and one-shot operation
- Internal prescaler allows 1, 1/4, 1/16, 1/64 of peripheral clock as counter clock or of selected Reload timer underflow as clock input
- Can be triggered by software or reload timer
- Can trigger ADC conversion
- Timing point capture
- Start delay

Stepping Motor Controller

- Stepping Motor Controller with integrated high current output drivers
- Four high current outputs for each channel
- Two synchronized 8/10-bit PWMs per channel
- Internal prescaling for PWM clock: 1, 1/4, 1/5, 1/6, 1/8, 1/10, 1/12, 1/16 of peripheral clock
- Dedicated power supply for high current output drivers

LCD Controller

- LCD controller with up to $4\text{COM} \times 44\text{SEG}$
- Internal or external voltage generation
- Duty cycle: Selectable from options: 1/2, 1/3 and 1/4
- Fixed 1/3 bias
- Programmable frame period
- Clock source selectable from four options (main clock, peripheral clock, subclock or RC oscillator clock)
- Internal divider resistors or external divider resistors
- On-chip data memory for display
- LCD display can be operated in Timer Mode
- Blank display: selectable
- All SEG, COM and V pins can be switched between general and specialized purposes

Sound Generator

- 8-bit PWM signal is mixed with tone frequency from 16-bit reload counter
- PWM clock by internal prescaler: 1, 1/2, 1/4, 1/8 of peripheral clock

Real Time Clock

- Operational on main oscillation (4MHz), sub oscillation (32kHz) or RC oscillation (100kHz/2MHz)
- Capable to correct oscillation deviation of Sub clock or RC oscillator clock (clock calibration)
- Read/write accessible second/minute/hour registers
- Can signal interrupts every half second/second/minute/hour/day
- Internal clock divider and prescaler provide exact 1s clock

External Interrupts

- Edge or Level sensitive
- Interrupt mask bit per channel
- Each available CAN channel RX has an external interrupt for wake-up
- Selected USART channels SIN have an external interrupt for wake-up

Non Maskable Interrupt

- Disabled after reset, can be enabled by Boot-ROM depending on ROM configuration block
- Once enabled, cannot be disabled other than by reset
- High or Low level sensitive
- Pin shared with external interrupt 0

I/O Ports

- Most of the external pins can be used as general purpose I/O
- All push-pull outputs (except when used as I²C SDA/SCL line)
- Bit-wise programmable as input/output or peripheral signal
- Bit-wise programmable input enable

- One input level per GPIO-pin (either Automotive or CMOS hysteresis)

- Bit-wise programmable pull-up resistor

Built-in On Chip Debugger (OCD)

- One-wire debug tool interface
- Break function
 - Hardware break: 6 points (shared with code event)
 - Software break: 4096 points
- Event function
 - Code event: 6 points (shared with hardware break)
 - Data event: 6 points
 - Event sequencer: 2 levels + reset
- Execution time measurement function
- Trace function: 42 branches
- Security function

Flash Memory

- Dual operation flash allowing reading of one Flash bank while programming or erasing the other bank
- Command sequencer for automatic execution of programming algorithm and for supporting DMA for programming of the Flash Memory
- Supports automatic programming, Embedded Algorithm
- Write/Erase/Erase-Suspend/Resume commands
- A flag indicating completion of the automatic algorithm
- Erase can be performed on each sector individually
- Sector protection
- Flash Security feature to protect the content of the Flash
- Low voltage detection during Flash erase or write

Contents

Features	1
1. Product Lineup	5
2. Block Diagram	6
3. Pin Assignment	7
4. Pin Description	8
5. Pin Circuit Type	10
6. I/O Circuit Type	14
7. Memory Map	21
8. Ramstart Addresses	22
9. User ROM Memory Map for Flash Devices	23
10. Serial Programming Communication Interface	24
11. Interrupt Vector Table	25
12. Handling Precautions	29
12.1 Precautions for Product Design.....	29
12.2 Precautions for Package Mounting.....	30
12.3 Precautions for Use Environment.....	31
13. HANDLING DEVICES	32
14. Electrical Characteristics	36
14.1 Absolute Maximum Ratings.....	36
14.2 Recommended Operating Conditions	39
14.3 DC Characteristics	40
14.3.1 Current Rating.....	40
14.3.2 Pin Characteristics	43
14.4 AC Characteristics.....	46
14.4.1 Main Clock Input Characteristics.....	46
14.4.2 Sub Clock Input Characteristics	47
14.4.3 Built-in RC Oscillation Characteristics.....	48
14.4.4 Internal Clock Timing	48
14.4.5 Operating Conditions of PLL	49
14.4.6 Reset Input.....	49
14.4.7 Power-on Reset Timing.....	50
14.4.8 USART Timing	51
14.4.9 External Input Timing	53
14.4.10 I ² C Timing.....	54
14.5 A/D Converter.....	55
14.5.1 Electrical Characteristics for the A/D Converter	55
14.5.2 Accuracy and Setting of the A/D Converter Sampling Time.....	56
14.5.3 Definition of A/D Converter Terms	57
14.6 High Current Output Slew Rate	59
14.7 Low Voltage Detection Function Characteristics	60
14.8 Flash Memory Write/Erase Characteristics	62
15. Example Characteristics	63
16. Ordering Information	66
17. Package Dimension	67
18. Major Changes	68
Document History	75
Sales, Solutions, and Legal Information	76

1. Product Lineup

Features		CY966A0	Remark
Product Type		Flash Memory Product	
Subclock		Subclock can be set by software	
Dual Operation Flash Memory	RAM	-	
128.5KB + 32KB	8KB	CY96F6A5R, CY96F6A5A	Product Options R: MCU with CAN A: MCU without CAN
256.5KB + 32KB	16KB	CY96F6A6R	
Package		LQFP-120 LQM120	
DMA		4ch	
USART		5ch	LIN-USART 0 to 2/4/5
	with automatic LIN-Header transmission/reception	2ch	LIN-USART 0/1
	with 16 byte RX- and TX-FIFO		
I ² C		1ch	I ² C 0
8/10-bit A/D Converter		32ch	AN 0 to 31
	with Data Buffer	No	
	with Range Comparator	Yes	
	with Scan Disable	Yes	
	with ADC Pulse Detection	Yes	
16-bit Reload Timer (RLT)		5ch	RLT 0 to 3/6
16-bit Free-Running Timer (FRT)		2ch	FRT 0/1
16-bit Input Capture Unit (ICU)		8ch (5 channels for LIN-USART)	ICU 0 to 7 (ICU 0/1/4 to 6 for LIN-USART)
16-bit Output Compare Unit (OCU)		4ch	OCU 0 to 3
8/16-bit Programmable Pulse Generator (PPG)		12ch (16-bit) / 24ch (8-bit)	PPG 0 to 7/12 to 15
	with Timing point capture	Yes	
	with Start delay	Yes	
	with Ramp	No	
CAN Interface		1ch	CAN 0 32 Message Buffers
Stepping Motor Controller (SMC)		5ch	SMC 0 to 4
External Interrupts (INT)		16ch	INT 0 to 15
Non-Maskable Interrupt (NMI)		1ch	
Sound Generator (SG)		2ch	SG 0/1
LCD Controller		4COM x 44SEG	COM 0 to 3 SEG 0 to 4/7 to 45
Real Time Clock (RTC)		1ch	
I/O Ports		95 (Dual clock mode) 97 (Single clock mode)	
Clock Calibration Unit (CAL)		1ch	
Clock Output Function		2ch	
Low Voltage Detection Function		Yes	Low voltage detection function can be disabled by software
Hardware Watchdog Timer		Yes	
On-chip RC-oscillator		Yes	
On-chip Debugger		Yes	

Note: All signals of the peripheral function in each product cannot be allocated by limiting the pins of package. It is necessary to use the port relocate function of the general I/O port according to your function use.

2. Block Diagram

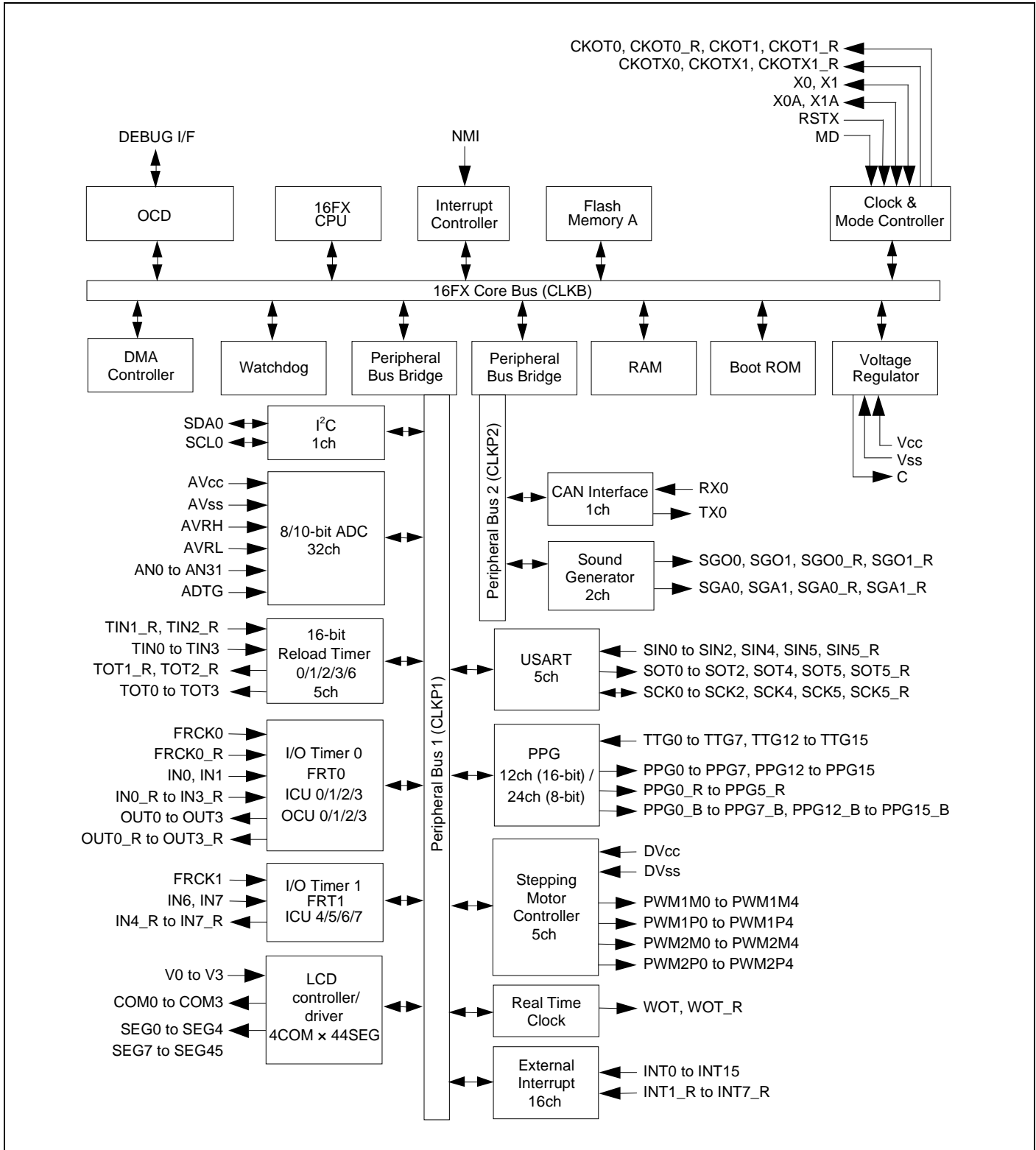

3. Pin Assignment

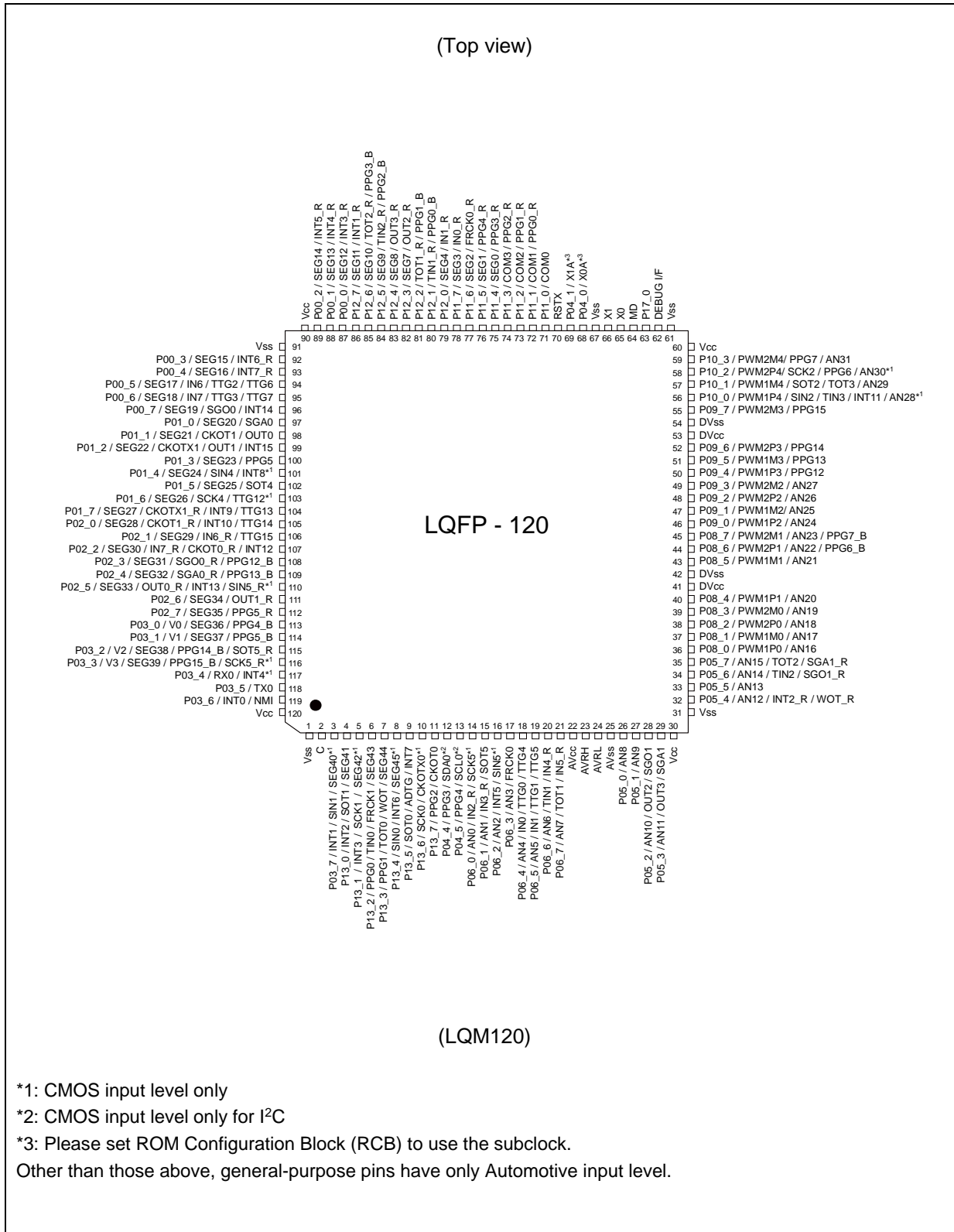

4. Pin Description

Pin Name	Feature	Description
ADTG	ADC	A/D converter trigger input pin
ANn	ADC	A/D converter channel n input pin
AVcc	Supply	Analog circuits power supply pin
AVRH	ADC	A/D converter high reference voltage input pin
AVRL	ADC	A/D converter low reference voltage input pin
AVss	Supply	Analog circuits power supply pin
C	Voltage regulator	Internally regulated power supply stabilization capacitor pin
CKOTn	Clock Output function	Clock Output function n output pin
CKOTn_R	Clock Output function	Relocated Clock Output function n output pin
CKOTXn	Clock Output function	Clock Output function n inverted output pin
CKOTXn_R	Clock Output function	Relocated Clock Output function n inverted output pin
COMn	LCD	LCD Common driver pin
DEBUG I/F	OCD	On Chip Debugger input/output pin
DVcc	Supply	SMC pins power supply
DVss	Supply	SMC pins power supply
FRCKn	Free-Running Timer	Free-Running Timer n input pin
FRCKn_R	Free-Running Timer	Relocated Free-Running Timer n input pin
INn	ICU	Input Capture Unit n input pin
INn_R	ICU	Relocated Input Capture Unit n input pin
INTn	External Interrupt	External Interrupt n input pin
INTn_R	External Interrupt	Relocated External Interrupt n input pin
MD	Core	Input pin for specifying the operating mode
NMI	External Interrupt	Non-Maskable Interrupt input pin
OUTn	OCU	Output Compare Unit n waveform output pin
OUTn_R	OCU	Relocated Output Compare Unit n waveform output pin
Pnn_m	GPIO	General purpose I/O pin
PPGn	PPG	Programmable Pulse Generator n output pin (16bit/8bit)
PPGn_R	PPG	Relocated Programmable Pulse Generator n output pin (16bit/8bit)
PPGn_B	PPG	Programmable Pulse Generator n output pin (16bit/8bit)
PWMn	SMC	SMC PWM high current output pin
RSTX	Core	Reset input pin
RXn	CAN	CAN interface n RX input pin
SCKn	USART	USART n serial clock input/output pin
SCKn_R	USART	Relocated USART n serial clock input/output pin
SCLn	I ² C	I ² C interface n clock I/O input/output pin
SDAn	I ² C	I ² C interface n serial data I/O input/output pin
SEGn	LCD	LCD Segment driver pin
SGAn	Sound Generator	Sound Generator amplitude output pin
SGAn_R	Sound Generator	Relocated Sound Generator amplitude output pin
SGOn	Sound Generator	Sound Generator sound/tone output pin

Pin Name	Feature	Description
SGOn_R	Sound Generator	Relocated Sound Generator sound/tone output pin
SINn	USART	USART n serial data input pin
SINn_R	USART	Relocated USART n serial data input pin
SOTn	USART	USART n serial data output pin
SOTn_R	USART	Relocated USART n serial data output pin
TINn	Reload Timer	Reload Timer n event input pin
TINn_R	Reload Timer	Relocated Reload Timer n event input pin
TOTn	Reload Timer	Reload Timer n output pin
TOTn_R	Reload Timer	Relocated Reload Timer n output pin
TTGn	PPG	Programmable Pulse Generator n trigger input pin
TXn	CAN	CAN interface n TX output pin
Vn	LCD	LCD voltage reference pin
Vcc	Supply	Power supply pin
Vss	Supply	Power supply pin
WOT	RTC	Real Time clock output pin
WOT_R	RTC	Relocated Real Time clock output pin
X0	Clock	Oscillator input pin
X0A	Clock	Subclock Oscillator input pin
X1	Clock	Oscillator output pin
X1A	Clock	Subclock Oscillator output pin

5. Pin Circuit Type

Pin No.	I/O Circuit Type*	Pin Name
1	Supply	Vss
2	F	C
3	P	P03_7 / INT1 / SIN1 / SEG40
4	J	P13_0 / INT2 / SOT1 / SEG41
5	P	P13_1 / INT3 / SCK1 / SEG42
6	J	P13_2 / PPG0 / TIN0 / FRCK1 / SEG43
7	J	P13_3 / PPG1 / TOT0 / WOT / SEG44
8	P	P13_4 / SIN0 / INT6 / SEG45
9	H	P13_5 / SOT0 / ADTG / INT7
10	M	P13_6 / SCK0 / CKOTX0
11	H	P13_7 / PPG2 / CKOT0
12	N	P04_4 / PPG3 / SDA0
13	N	P04_5 / PPG4 / SCL0
14	I	P06_0 / AN0 / IN2_R / SCK5
15	K	P06_1 / AN1 / IN3_R / SOT5
16	I	P06_2 / AN2 / INT5 / SIN5
17	K	P06_3 / AN3 / FRCK0
18	K	P06_4 / AN4 / IN0 / TTG0 / TTG4
19	K	P06_5 / AN5 / IN1 / TTG1 / TTG5
20	K	P06_6 / AN6 / TIN1 / IN4_R
21	K	P06_7 / AN7 / TOT1 / IN5_R
22	Supply	AVcc
23	G	AVRH
24	G	AVRL
25	Supply	AVss
26	K	P05_0 / AN8
27	K	P05_1 / AN9
28	K	P05_2 / AN10 / OUT2 / SGO1
29	K	P05_3 / AN11 / OUT3 / SGA1
30	Supply	Vcc
31	Supply	Vss
32	K	P05_4 / AN12 / INT2_R / WOT_R
33	K	P05_5 / AN13
34	K	P05_6 / AN14 / TIN2 / SGO1_R
35	K	P05_7 / AN15 / TOT2 / SGA1_R
36	R	P08_0 / PWM1P0 / AN16
37	R	P08_1 / PWM1M0 / AN17

Pin No.	I/O Circuit Type*	Pin Name
38	R	P08_2 / PWM2P0 / AN18
39	R	P08_3 / PWM2M0 / AN19
40	R	P08_4 / PWM1P1 / AN20
41	Supply	DVcc
42	Supply	DVss
43	R	P08_5 / PWM1M1 / AN21
44	R	P08_6 / PWM2P1 / AN22 / PPG6_B
45	R	P08_7 / PWM2M1 / AN23 / PPG7_B
46	R	P09_0 / PWM1P2 / AN24
47	R	P09_1 / PWM1M2 / AN25
48	R	P09_2 / PWM2P2 / AN26
49	R	P09_3 / PWM2M2 / AN27
50	T	P09_4 / PWM1P3 / PPG12
51	T	P09_5 / PWM1M3 / PPG13
52	T	P09_6 / PWM2P3 / PPG14
53	Supply	DVcc
54	Supply	DVss
55	T	P09_7 / PWM2M3 / PPG15
56	S	P10_0 / PWM1P4 / SIN2 / TIN3 / INT11 / AN28
57	R	P10_1 / PWM1M4 / SOT2 / TOT3 / AN29
58	S	P10_2 / PWM2P4 / SCK2 / PPG6 / AN30
59	R	P10_3 / PWM2M4 / PPG7 / AN31
60	Supply	Vcc
61	Supply	Vss
62	O	DEBUG I/F
63	H	P17_0
64	C	MD
65	A	X0
66	A	X1
67	Supply	Vss
68	B	P04_0 / X0A
69	B	P04_1 / X1A
70	C	RSTX
71	J	P11_0 / COM0
72	J	P11_1 / COM1 / PPG0_R
73	J	P11_2 / COM2 / PPG1_R
74	J	P11_3 / COM3 / PPG2_R
75	J	P11_4 / SEG0 / PPG3_R
76	J	P11_5 / SEG1 / PPG4_R

Pin No.	I/O Circuit Type*	Pin Name
77	J	P11_6 / SEG2 / FRCK0_R
78	J	P11_7 / SEG3 / IN0_R
79	J	P12_0 / SEG4 / IN1_R
80	H	P12_1 / TIN1_R / PPG0_B
81	H	P12_2 / TOT1_R / PPG1_B
82	J	P12_3 / SEG7 / OUT2_R
83	J	P12_4 / SEG8 / OUT3_R
84	J	P12_5 / SEG9 / TIN2_R / PPG2_B
85	J	P12_6 / SEG10 / TOT2_R / PPG3_B
86	J	P12_7 / SEG11 / INT1_R
87	J	P00_0 / SEG12 / INT3_R
88	J	P00_1 / SEG13 / INT4_R
89	J	P00_2 / SEG14 / INT5_R
90	Supply	Vcc
91	Supply	Vss
92	J	P00_3 / SEG15 / INT6_R
93	J	P00_4 / SEG16 / INT7_R
94	J	P00_5 / SEG17 / IN6 / TTG2 / TTG6
95	J	P00_6 / SEG18 / IN7 / TTG3 / TTG7
96	J	P00_7 / SEG19 / SGO0 / INT14
97	J	P01_0 / SEG20 / SGA0
98	J	P01_1 / SEG21 / CKOT1 / OUT0
99	J	P01_2 / SEG22 / CKOTX1 / OUT1 / INT15
100	J	P01_3 / SEG23 / PPG5
101	P	P01_4 / SEG24 / SIN4 / INT8
102	J	P01_5 / SEG25 / SOT4
103	P	P01_6 / SEG26 / SCK4 / TTG12
104	J	P01_7 / SEG27 / CKOTX1_R / INT9 / TTG13
105	J	P02_0 / SEG28 / CKOT1_R / INT10 / TTG14
106	J	P02_1 / SEG29 / IN6_R / TTG15
107	J	P02_2 / SEG30 / IN7_R / CKOT0_R / INT12
108	J	P02_3 / SEG31 / SGO0_R / PPG12_B
109	J	P02_4 / SEG32 / SGA0_R / PPG13_B
110	P	P02_5 / SEG33 / OUT0_R / INT13 / SIN5_R
111	J	P02_6 / SEG34 / OUT1_R
112	J	P02_7 / SEG35 / PPG5_R
113	L	P03_0 / V0 / SEG36 / PPG4_B
114	L	P03_1 / V1 / SEG37 / PPG5_B
115	L	P03_2 / V2 / SEG38 / PPG14_B / SOT5_R

Pin No.	I/O Circuit Type*	Pin Name
116	Q	P03_3 / V3 / SEG39 / PPG15_B / SCK5_R
117	M	P03_4 / RX0 / INT4
118	H	P03_5 / TX0
119	H	P03_6 / INTO / NMI
120	Supply	Vcc

*: See "I/O Circuit Type" for details on the I/O circuit types.

6. I/O Circuit Type

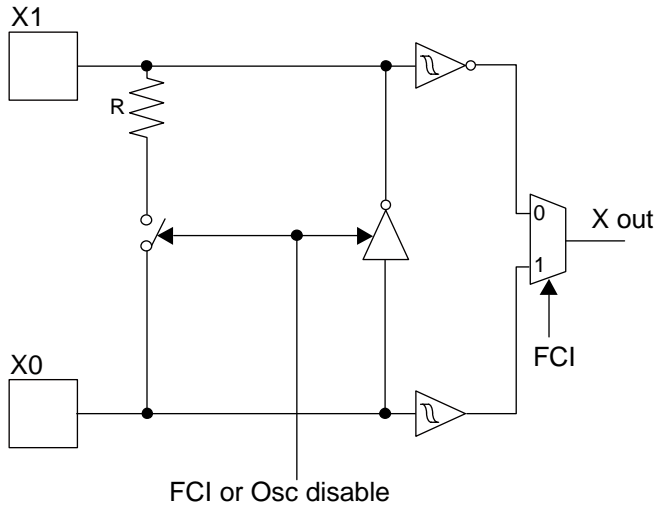
Type	Circuit	Remarks
A	 <p>The diagram illustrates a high-speed oscillation circuit. It features two pins, X0 and X1, connected to a crystal resonator. A feedback resistor R is connected to X1. A switch labeled "FCI or Osc disable" is connected to the circuit. The output is labeled "X out" and is connected to a multiplexer with inputs 0 and 1, where input 1 is labeled "FCI".</p>	<p>High-speed oscillation circuit:</p> <ul style="list-style-type: none"> ■ Programmable between oscillation mode (external crystal or resonator connected to X0/X1 pins) and Fast external Clock Input (FCI) mode (external clock connected to X0 pin) ■ Feedback resistor = approx. 1.0MΩ ■ The amplitude: 1.8V±0.15V to operate by the internal supply voltage

Type	Circuit	Remarks
B		<p>Low-speed oscillation circuit shared with GPIO functionality:</p> <ul style="list-style-type: none"> ■ Feedback resistor = approx. 5.0MΩ ■ GPIO functionality selectable (CMOS level output (I_{OL} = 4mA, I_{OH} = -4mA), Automotive input with input shutdown function and programmable pull-up resistor)
C		<p>CMOS hysteresis input pin</p>

Type	Circuit	Remarks
F		<p>Power supply input protection circuit</p>
G		<ul style="list-style-type: none"> ■ A/D converter ref+ (AVRH)/ ref- (AVRL) power supply input pin with protection circuit ■ Without protection circuit against V_{CC} for pins AVRH/AVRL
H		<ul style="list-style-type: none"> ■ CMOS level output (I_{OL} = 4mA, I_{OH} = -4mA) ■ Automotive input with input shutdown function ■ Programmable pull-up resistor
I		<ul style="list-style-type: none"> ■ CMOS level output (I_{OL} = 4mA, I_{OH} = -4mA) ■ CMOS hysteresis input with input shutdown function ■ Programmable pull-up resistor ■ Analog input

Type	Circuit	Remarks
J		<ul style="list-style-type: none"> ■ CMOS level output ($I_{OL} = 4\text{mA}$, $I_{OH} = -4\text{mA}$) ■ Automotive input with input shutdown function ■ Programmable pull-up resistor ■ SEG or COM output
K		<ul style="list-style-type: none"> ■ CMOS level output ($I_{OL} = 4\text{mA}$, $I_{OH} = -4\text{mA}$) ■ Automotive input with input shutdown function ■ Programmable pull-up resistor ■ Analog input
L		<ul style="list-style-type: none"> ■ CMOS level output ($I_{OL} = 4\text{mA}$, $I_{OH} = -4\text{mA}$) ■ Automotive input with input shutdown function ■ Programmable pull-up resistor ■ Vn input or SEG output

Type	Circuit	Remarks
M		<ul style="list-style-type: none"> ■ CMOS level output ($I_{OL} = 4\text{mA}$, $I_{OH} = -4\text{mA}$) ■ CMOS hysteresis input with input shutdown function ■ Programmable pull-up resistor
N		<ul style="list-style-type: none"> ■ CMOS level output ($I_{OL} = 3\text{mA}$, $I_{OH} = -3\text{mA}$) ■ CMOS hysteresis input with input shutdown function ■ Programmable pull-up resistor <p>*: N-channel transistor has slew rate control according to I^2C spec, irrespective of usage.</p>
O		<ul style="list-style-type: none"> ■ Open-drain I/O ■ Output 25mA, $V_{CC} = 2.7\text{V}$ ■ TTL input

Type	Circuit	Remarks
P		<ul style="list-style-type: none"> ■ CMOS level output ($I_{OL} = 4\text{mA}$, $I_{OH} = -4\text{mA}$) ■ CMOS hysteresis inputs with input shutdown function ■ Programmable pull-up resistor ■ SEG or COM output
Q		<ul style="list-style-type: none"> ■ CMOS level output ($I_{OL} = 4\text{mA}$, $I_{OH} = -4\text{mA}$) ■ CMOS hysteresis inputs with input shutdown function ■ Programmable pull-up resistor ■ Vn input or SEG output
R		<ul style="list-style-type: none"> ■ CMOS level output (programmable $I_{OL} = 4\text{mA}$, $I_{OH} = -4\text{mA}$ and $I_{OL} = 30\text{mA}$, $I_{OH} = -30\text{mA}$) ■ Automotive input with input shutdown function ■ Programmable pull-up / pull-down resistor ■ Analog input

Type	Circuit	Remarks
S	<p>Standby control for input shutdown</p> <p>Pull-up control</p> <p>Pout</p> <p>Nout</p> <p>Pull-down control</p> <p>R</p> <p>Hysteresis input</p> <p>Analog input</p>	<ul style="list-style-type: none"> ■ CMOS level output (programmable $I_{OL} = 4\text{mA}$, $I_{OH} = -4\text{mA}$ and $I_{OL} = 30\text{mA}$, $I_{OH} = -30\text{mA}$) ■ CMOS hysteresis input with input shutdown function ■ Programmable pull-up / pull-down resistor ■ Analog input
T	<p>Standby control for input shutdown</p> <p>Pull-up control</p> <p>Pout</p> <p>Nout</p> <p>Pull-down control</p> <p>R</p> <p>Automotive input</p>	<ul style="list-style-type: none"> ■ CMOS level output (programmable $I_{OL} = 4\text{mA}$, $I_{OH} = -4\text{mA}$ and $I_{OL} = 30\text{mA}$, $I_{OH} = -30\text{mA}$) ■ Automotive input with input shutdown function ■ Programmable pull-up / pull-down resistor

7. Memory Map

FF:FFFF _H	USER ROM*1
DE:0000 _H DD:FFFF _H	Reserved
10:0000 _H	Boot-ROM
0F:C000 _H	Peripheral
0E:9000 _H	Reserved
01:0000 _H	ROM/RAM MIRROR
00:8000 _H	Internal RAM bank0
RAMSTART0*2	Reserved
00:0C00 _H	Peripheral
00:0380 _H	GPR*3
00:0180 _H	DMA
00:0100 _H	Reserved
00:00F0 _H	Reserved
00:0000 _H	Peripheral

*1: For details about USER ROM area, see “User ROM Memory Map For Flash Devices” on the following pages.

*2: For RAMSTART addresses, see the table on the next page.

*3: Unused GPR banks can be used as RAM area.

GPR: General-Purpose Register

The DMA area is only available if the device contains the corresponding resource.

The available RAM and ROM area depends on the device.

8. Ramstart Addresses

Devices	Bank 0 RAM Size	RAMSTART0
CY96F6A5	8KB	00:6200 _H
CY96F6A6	16KB	00:4200 _H

9. User ROM Memory Map for Flash Devices

		CY96F6A5		CY96F6A6	
CPU mode address	Flash memory mode address	Flash size 128.5KB + 32KB		Flash size 256.5KB + 32KB	
FF:FFFF _H	3F:FFFF _H	SA39 - 64KB		SA39 - 64KB	Bank A of Flash A
FF:0000 _H	3F:0000 _H				
FE:FFFF _H	3E:FFFF _H	SA38 - 64KB		SA38 - 64KB	
FE:0000 _H	3E:0000 _H				
FD:FFFF _H	3D:FFFF _H	Reserved		SA37 - 64KB	
FD:0000 _H	3D:0000 _H				
FC:FFFF _H	3C:FFFF _H			SA36 - 64KB	
FC:0000 _H	3C:0000 _H				
FB:FFFF _H				Reserved	
DF:A000 _H				Reserved	
DF:9FFF _H	1F:9FFF _H	SA4 - 8KB		SA4 - 8KB	Bank B of Flash A
DF:8000 _H	1F:8000 _H				
DF:7FFF _H	1F:7FFF _H	SA3 - 8KB		SA3 - 8KB	
DF:6000 _H	1F:6000 _H				
DF:5FFF _H	1F:5FFF _H	SA2 - 8KB		SA2 - 8KB	
DF:4000 _H	1F:4000 _H				
DF:3FFF _H	1F:3FFF _H	SA1 - 8KB		SA1 - 8KB	
DF:2000 _H	1F:2000 _H				
DF:1FFF _H	1F:1FFF _H	SAS - 512B*		SAS - 512B*	Bank A of Flash A
DF:0000 _H	1F:0000 _H				
DE:FFFF _H		Reserved		Reserved	
DE:0000 _H					

*: Physical address area of SAS-512B is from DF:0000_H to DF:01FF_H.

Others (from DF:0200_H to DF:1FFF_H) is mirror area of SAS-512B.

Sector SAS contains the ROM configuration block RCBA at CPU address DF:0000_H -DF:01FF_H.

SAS can not be used for E²PROM emulation.

10. Serial Programming Communication Interface

USART pins for Flash serial programming (MD = 0, DEBUG I/F = 0, Serial Communication mode)

CY966A0		
Pin Number	USART Number	Normal Function
8	USART0	SIN0
9		SOT0
10		SCK0
3	USART1	SIN1
4		SOT1
5		SCK1
56	USART2	SIN2
57		SOT2
58		SCK2
101	USART4	SIN4
102		SOT4
103		SCK4

11. Interrupt Vector Table

Vector Number	Offset in Vector Table	Vector Name	Cleared by DMA	Index in ICR to Program	Description
0	3FC _H	CALLV0	No	-	CALLV instruction
1	3F8 _H	CALLV1	No	-	CALLV instruction
2	3F4 _H	CALLV2	No	-	CALLV instruction
3	3F0 _H	CALLV3	No	-	CALLV instruction
4	3EC _H	CALLV4	No	-	CALLV instruction
5	3E8 _H	CALLV5	No	-	CALLV instruction
6	3E4 _H	CALLV6	No	-	CALLV instruction
7	3E0 _H	CALLV7	No	-	CALLV instruction
8	3DC _H	RESET	No	-	Reset vector
9	3D8 _H	INT9	No	-	INT9 instruction
10	3D4 _H	EXCEPTION	No	-	Undefined instruction execution
11	3D0 _H	NMI	No	-	Non-Maskable Interrupt
12	3CC _H	DLY	No	12	Delayed Interrupt
13	3C8 _H	RC_TIMER	No	13	RC Clock Timer
14	3C4 _H	MC_TIMER	No	14	Main Clock Timer
15	3C0 _H	SC_TIMER	No	15	Sub Clock Timer
16	3BC _H	LVDI	No	16	Low Voltage Detector
17	3B8 _H	EXTINT0	Yes	17	External Interrupt 0
18	3B4 _H	EXTINT1	Yes	18	External Interrupt 1
19	3B0 _H	EXTINT2	Yes	19	External Interrupt 2
20	3AC _H	EXTINT3	Yes	20	External Interrupt 3
21	3A8 _H	EXTINT4	Yes	21	External Interrupt 4
22	3A4 _H	EXTINT5	Yes	22	External Interrupt 5
23	3A0 _H	EXTINT6	Yes	23	External Interrupt 6
24	39C _H	EXTINT7	Yes	24	External Interrupt 7
25	398 _H	EXTINT8	Yes	25	External Interrupt 8
26	394 _H	EXTINT9	Yes	26	External Interrupt 9
27	390 _H	EXTINT10	Yes	27	External Interrupt 10
28	38C _H	EXTINT11	Yes	28	External Interrupt 11
29	388 _H	EXTINT12	Yes	29	External Interrupt 12
30	384 _H	EXTINT13	Yes	30	External Interrupt 13
31	380 _H	EXTINT14	Yes	31	External Interrupt 14
32	37C _H	EXTINT15	Yes	32	External Interrupt 15
33	378 _H	CAN0	No	33	CAN Controller 0
34	374 _H	-	-	34	Reserved
35	370 _H	-	-	35	Reserved
36	36C _H	-	-	36	Reserved
37	368 _H	-	-	37	Reserved
38	364 _H	PPG0	Yes	38	Programmable Pulse Generator 0
39	360 _H	PPG1	Yes	39	Programmable Pulse Generator 1

Vector Number	Offset in Vector Table	Vector Name	Cleared by DMA	Index in ICR to Program	Description
40	35C _H	PPG2	Yes	40	Programmable Pulse Generator 2
41	358 _H	PPG3	Yes	41	Programmable Pulse Generator 3
42	354 _H	PPG4	Yes	42	Programmable Pulse Generator 4
43	350 _H	PPG5	Yes	43	Programmable Pulse Generator 5
44	34C _H	PPG6	Yes	44	Programmable Pulse Generator 6
45	348 _H	PPG7	Yes	45	Programmable Pulse Generator 7
46	344 _H	-	-	46	Reserved
47	340 _H	-	-	47	Reserved
48	33C _H	-	-	48	Reserved
49	338 _H	-	-	49	Reserved
50	334 _H	PPG12	Yes	50	Programmable Pulse Generator 12
51	330 _H	PPG13	Yes	51	Programmable Pulse Generator 13
52	32C _H	PPG14	Yes	52	Programmable Pulse Generator 14
53	328 _H	PPG15	Yes	53	Programmable Pulse Generator 15
54	324 _H	-	-	54	Reserved
55	320 _H	-	-	55	Reserved
56	31C _H	-	-	56	Reserved
57	318 _H	-	-	57	Reserved
58	314 _H	RLT0	Yes	58	Reload Timer 0
59	310 _H	RLT1	Yes	59	Reload Timer 1
60	30C _H	RLT2	Yes	60	Reload Timer 2
61	308 _H	RLT3	Yes	61	Reload Timer 3
62	304 _H	-	-	62	Reserved
63	300 _H	-	-	63	Reserved
64	2FC _H	RLT6	Yes	64	Reload Timer 6
65	2F8 _H	ICU0	Yes	65	Input Capture Unit 0
66	2F4 _H	ICU1	Yes	66	Input Capture Unit 1
67	2F0 _H	ICU2	Yes	67	Input Capture Unit 2
68	2EC _H	ICU3	Yes	68	Input Capture Unit 3
69	2E8 _H	ICU4	Yes	69	Input Capture Unit 4
70	2E4 _H	ICU5	Yes	70	Input Capture Unit 5
71	2E0 _H	ICU6	Yes	71	Input Capture Unit 6
72	2DC _H	ICU7	Yes	72	Input Capture Unit 7
73	2D8 _H	-	-	73	Reserved
74	2D4 _H	-	-	74	Reserved
75	2D0 _H	-	-	75	Reserved
76	2CC _H	-	-	76	Reserved
77	2C8 _H	OCU0	Yes	77	Output Compare Unit 0

Vector Number	Offset in Vector Table	Vector Name	Cleared by DMA	Index in ICR to Program	Description
78	2C4 _H	OCU1	Yes	78	Output Compare Unit 1
79	2C0 _H	OCU2	Yes	79	Output Compare Unit 2
80	2BC _H	OCU3	Yes	80	Output Compare Unit 3
81	2B8 _H	-	-	81	Reserved
82	2B4 _H	-	-	82	Reserved
83	2B0 _H	-	-	83	Reserved
84	2AC _H	-	-	84	Reserved
85	2A8 _H	-	-	85	Reserved
86	2A4 _H	-	-	86	Reserved
87	2A0 _H	-	-	87	Reserved
88	29C _H	-	-	88	Reserved
89	298 _H	FRT0	Yes	89	Free-Running Timer 0
90	294 _H	FRT1	Yes	90	Free-Running Timer 1
91	290 _H	-	-	91	Reserved
92	28C _H	-	-	92	Reserved
93	288 _H	RTC0	No	93	Real Time Clock
94	284 _H	CAL0	No	94	Clock Calibration Unit
95	280 _H	SG0	No	95	Sound Generator 0
96	27C _H	IIC0	Yes	96	I ² C interface 0
97	278 _H	-	-	97	Reserved
98	274 _H	ADC0	Yes	98	A/D Converter 0
99	270 _H	-	-	99	Reserved
100	26C _H	-	-	100	Reserved
101	268 _H	LINR0	Yes	101	LIN USART 0 RX
102	264 _H	LINT0	Yes	102	LIN USART 0 TX
103	260 _H	LINR1	Yes	103	LIN USART 1 RX
104	25C _H	LINT1	Yes	104	LIN USART 1 TX
105	258 _H	LINR2	Yes	105	LIN USART 2 RX
106	254 _H	LINT2	Yes	106	LIN USART 2 TX
107	250 _H	-	-	107	Reserved
108	24C _H	-	-	108	Reserved
109	248 _H	LINR4	Yes	109	LIN USART 4 RX
110	244 _H	LINT4	Yes	110	LIN USART 4 TX
111	240 _H	LINR5	Yes	111	LIN USART 5 RX
112	23C _H	LINT5	Yes	112	LIN USART 5 TX
113	238 _H	-	-	113	Reserved
114	234 _H	-	-	114	Reserved
115	230 _H	-	-	115	Reserved

Vector Number	Offset in Vector Table	Vector Name	Cleared by DMA	Index in ICR to Program	Description
116	22C _H	-	-	116	Reserved
117	228 _H	-	-	117	Reserved
118	224 _H	-	-	118	Reserved
119	220 _H	-	-	119	Reserved
120	21C _H	-	-	120	Reserved
121	218 _H	SG1	No	121	Sound Generator 1
122	214 _H	-	-	122	Reserved
123	210 _H	-	-	123	Reserved
124	20C _H	-	-	124	Reserved
125	208 _H	-	-	125	Reserved
126	204 _H	-	-	126	Reserved
127	200 _H	-	-	127	Reserved
128	1FC _H	-	-	128	Reserved
129	1F8 _H	-	-	129	Reserved
130	1F4 _H	-	-	130	Reserved
131	1F0 _H	-	-	131	Reserved
132	1EC _H	-	-	132	Reserved
133	1E8 _H	FLASHA	Yes	133	Flash memory A interrupt
134	1E4 _H	-	-	134	Reserved
135	1E0 _H	-	-	135	Reserved
136	1DC _H	-	-	136	Reserved
137	1D8 _H	-	-	137	Reserved
138	1D4 _H	-	-	138	Reserved
139	1D0 _H	ADCRC0	No	139	A/D Converter 0 - Range Comparator
140	1CC _H	ADCPD0	No	140	A/D Converter 0 - Pulse detection
141	1C8 _H	-	-	141	Reserved
142	1C4 _H	-	-	142	Reserved
143	1C0 _H	-	-	143	Reserved

12. Handling Precautions

Any semiconductor devices have inherently a certain rate of failure. The possibility of failure is greatly affected by the conditions in which they are used (circuit conditions, environmental conditions, etc.). This page describes precautions that must be observed to minimize the chance of failure and to obtain higher reliability from your Cypress semiconductor devices.

12.1 Precautions for Product Design

This section describes precautions when designing electronic equipment using semiconductor devices.

■ Absolute Maximum Ratings

Semiconductor devices can be permanently damaged by application of stress (voltage, current, temperature, etc.) in excess of certain established limits, called absolute maximum ratings. Do not exceed these ratings.

■ Recommended Operating Conditions

Recommended operating conditions are normal operating ranges for the semiconductor device. All the device's electrical characteristics are warranted when operated within these ranges.

Always use semiconductor devices within the recommended operating conditions. Operation outside these ranges may adversely affect reliability and could result in device failure.

No warranty is made with respect to uses, operating conditions, or combinations not represented on the data sheet. Users considering application outside the listed conditions are advised to contact their sales representative beforehand.

■ Processing and Protection of Pins

These precautions must be followed when handling the pins which connect semiconductor devices to power supply and input/output functions.

(1) Preventing Over-Voltage and Over-Current Conditions

Exposure to voltage or current levels in excess of maximum ratings at any pin is likely to cause deterioration within the device, and in extreme cases leads to permanent damage of the device. Try to prevent such overvoltage or over-current conditions at the design stage.

(2) Protection of Output Pins

Shorting of output pins to supply pins or other output pins, or connection to large capacitance can cause large current flows. Such conditions if present for extended periods of time can damage the device. Therefore, avoid this type of connection.

(3) Handling of Unused Input Pins

Unconnected input pins with very high impedance levels can adversely affect stability of operation. Such pins should be connected through an appropriate resistance to a power supply pin or ground pin.

■ Latch-up

Semiconductor devices are constructed by the formation of P-type and N-type areas on a substrate. When subjected to abnormally high voltages, internal parasitic PNPN junctions (called thyristor structures) may be formed, causing large current levels in excess of several hundred mA to flow continuously at the power supply pin. This condition is called latch-up.

CAUTION: The occurrence of latch-up not only causes loss of reliability in the semiconductor device, but can cause injury or damage from high heat, smoke or flame. To prevent this from happening, do the following:

- (1) Be sure that voltages applied to pins do not exceed the absolute maximum ratings. This should include attention to abnormal noise, surge levels, etc.
- (2) Be sure that abnormal current flows do not occur during the power-on sequence.

■ Observance of Safety Regulations and Standards

Most countries in the world have established standards and regulations regarding safety, protection from electromagnetic interference, etc. Customers are requested to observe applicable regulations and standards in the design of products.

■ Fail-Safe Design

Any semiconductor devices have inherently a certain rate of failure. You must protect against injury, damage or loss from such failures by incorporating safety design measures into your facility and equipment such as redundancy, fire protection, and prevention of over-current levels and other abnormal operating conditions.

■ Precautions Related to Usage of Devices

Cypress semiconductor devices are intended for use in standard applications (computers, office automation and other office equipment, industrial, communications, and measurement equipment, personal or household devices, etc.).

CAUTION: Customers considering the use of our products in special applications where failure or abnormal operation may directly affect human lives or cause physical injury or property damage, or where extremely high levels of reliability are demanded (such as aerospace systems, atomic energy controls, sea floor repeaters, vehicle operating controls, medical devices for life support, etc.) are requested to consult with sales representatives before such use. The company will not be responsible for damages arising from such use without prior approval.

12.2 Precautions for Package Mounting

Package mounting may be either lead insertion type or surface mount type. In either case, for heat resistance during soldering, you should only mount under Cypress's recommended conditions. For detailed information about mount conditions, contact your sales representative.

■ Lead Insertion Type

Mounting of lead insertion type packages onto printed circuit boards may be done by two methods: direct soldering on the board, or mounting by using a socket.

Direct mounting onto boards normally involves processes for inserting leads into through-holes on the board and using the flow soldering (wave soldering) method of applying liquid solder. In this case, the soldering process usually causes leads to be subjected to thermal stress in excess of the absolute ratings for storage temperature. Mounting processes should conform to Cypress recommended mounting conditions.

If socket mounting is used, differences in surface treatment of the socket contacts and IC lead surfaces can lead to contact deterioration after long periods. For this reason it is recommended that the surface treatment of socket contacts and IC leads be verified before mounting.

■ Surface Mount Type

Surface mount packaging has longer and thinner leads than lead-insertion packaging, and therefore leads are more easily deformed or bent. The use of packages with higher pin counts and narrower pin pitch results in increased susceptibility to open connections caused by deformed pins, or shorting due to solder bridges.

You must use appropriate mounting techniques. Cypress recommends the solder reflow method, and has established a ranking of mounting conditions for each product. Users are advised to Cypress mount packages in accordance with Cypress ranking of recommended conditions.

■ Lead-Free Packaging

CAUTION: When ball grid array (BGA) packages with Sn-Ag-Cu balls are mounted using Sn-Pb eutectic soldering, junction strength may be reduced under some conditions of use.

■ Storage of Semiconductor Devices

Because plastic chip packages are formed from plastic resins, exposure to natural environmental conditions will cause absorption of moisture. During mounting, the application of heat to a package that has absorbed moisture can cause surfaces to peel, reducing moisture resistance and causing packages to crack. To prevent, do the following:

- (1) Avoid exposure to rapid temperature changes, which cause moisture to condense inside the product. Store products in locations where temperature changes are slight.
- (2) Use dry boxes for product storage. Products should be stored below 70% relative humidity, and at temperatures between 5°C and 30°C.
When you open Dry Package that recommends humidity 40% to 70% relative humidity.
- (3) When necessary, Cypress packages semiconductor devices in highly moisture-resistant aluminum laminate bags, with a silica gel desiccant. Devices should be sealed in their aluminum laminate bags for storage.
- (4) Avoid storing packages where they are exposed to corrosive gases or high levels of dust.

■ Baking

Packages that have absorbed moisture may be de-moisturized by baking (heat drying). Follow the Cypress recommended conditions for baking.

Condition: 125°C/24 h

■ Static Electricity

Because semiconductor devices are particularly susceptible to damage by static electricity, you must take the following precautions:

- (1) Maintain relative humidity in the working environment between 40% and 70%. Use of an apparatus for ion generation may be needed to remove electricity.
- (2) Electrically ground all conveyors, solder vessels, soldering irons and peripheral equipment.
- (3) Eliminate static body electricity by the use of rings or bracelets connected to ground through high resistance (on the level of 1 MΩ).
Wearing of conductive clothing and shoes, use of conductive floor mats and other measures to minimize shock loads is recommended.
- (4) Ground all fixtures and instruments, or protect with anti-static measures.
- (5) Avoid the use of styrofoam or other highly static-prone materials for storage of completed board assemblies.

12.3 Precautions for Use Environment

Reliability of semiconductor devices depends on ambient temperature and other conditions as described above.

For reliable performance, do the following:

- (1) Humidity
Prolonged use in high humidity can lead to leakage in devices as well as printed circuit boards. If high humidity levels are anticipated, consider anti-humidity processing.
- (2) Discharge of Static Electricity
When high-voltage charges exist close to semiconductor devices, discharges can cause abnormal operation. In such cases, use anti-static measures or processing to prevent discharges.
- (3) Corrosive Gases, Dust, or Oil
Exposure to corrosive gases or contact with dust or oil may lead to chemical reactions that will adversely affect the device. If you use devices in such conditions, consider ways to prevent such exposure or to protect the devices.
- (4) Radiation, Including Cosmic Radiation
Most devices are not designed for environments involving exposure to radiation or cosmic radiation. Users should provide shielding as appropriate.
- (5) Smoke, Flame
CAUTION: Plastic molded devices are flammable, and therefore should not be used near combustible substances. If devices begin to smoke or burn, there is danger of the release of toxic gases.

Customers considering the use of Cypress products in other special environmental conditions should consult with sales representatives.

13. HANDLING DEVICES

Special Care is Required for the following when Handling the Device:

- Latch-up prevention
- Unused pins handling
- External clock usage
- Notes on PLL clock mode operation
- Power supply pins (V_{cc}/V_{ss})
- Crystal oscillator and ceramic resonator circuit
- Turn on sequence of power supply to A/D converter and analog inputs
- Pin handling when not using the A/D converter
- Notes on Power-on
- Stabilization of power supply voltage
- SMC power supply pins
- Serial communication
- Mode Pin (MD)

1. Latch-Up Prevention

CMOS IC chips may suffer latch-up under the following conditions:

- A voltage higher than V_{cc} or lower than V_{ss} is applied to an input or output pin.
- A voltage higher than the rated voltage is applied between V_{cc} pins and V_{ss} pins.
- The AV_{cc} power supply is applied before the V_{cc} voltage.

Latch-up may increase the power supply current dramatically, causing thermal damages to the device.

For the same reason, extra care is required to not let the analog power-supply voltage (AV_{cc}, AVRH) exceed the digital power-supply voltage.

2. Unused Pins Handling

Unused input pins can be left open when the input is disabled (corresponding bit of Port Input Enable register PIER = 0).

Leaving unused input pins open when the input is enabled may result in misbehavior and possible permanent damage of the device. To prevent latch-up, they must therefore be pulled up or pulled down through resistors which should be more than 2kΩ..

Unused bidirectional pins can be set either to the output state and be then left open, or to the input state with either input disabled or external pull-up/pull-down resistor as described above.

3. External Clock Usage

The permitted frequency range of an external clock depends on the oscillator type and configuration.

See AC Characteristics for detailed modes and frequency limits. Single and opposite phase external clocks must be connected as follows:

(1) Single Phase External Clock for Main Oscillator

When using a single phase external clock for the Main oscillator, X0 pin must be driven and X1 pin left open.

And supply 1.8V power to the external clock.

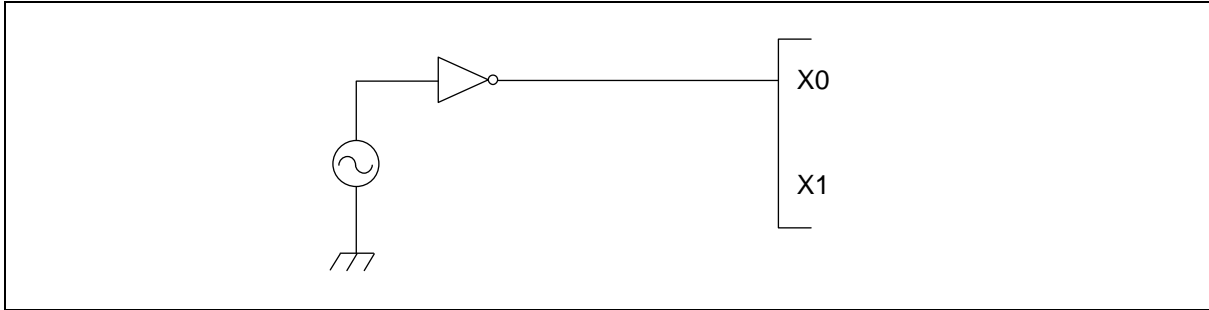

(2) Single Phase External Clock for Sub Oscillator

When using a single phase external clock for the Sub oscillator, “External clock mode” must be selected and X0A/P04_0 pin must be driven. X1A/P04_1 pin can be configured as GPIO.

(3) Opposite Phase External Clock

When using an opposite phase external clock, X1 (X1A) pins must be supplied with a clock signal which has the opposite phase to the X0 (X0A) pins. Supply level on X0 and X1 pins must be 1.8V.

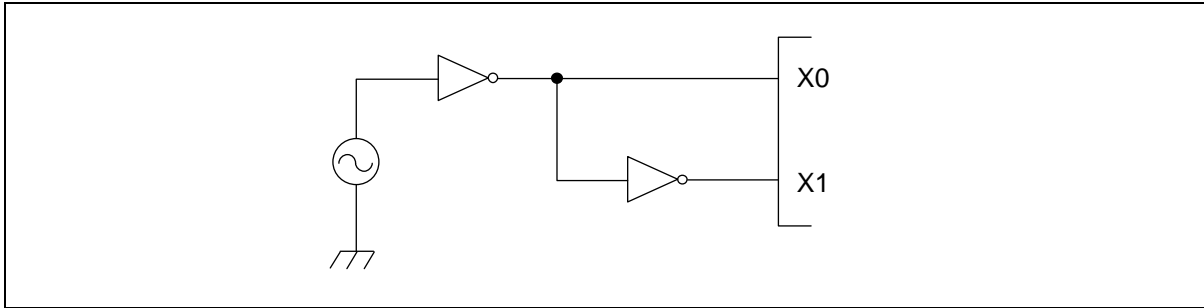

4. Notes on PLL Clock Mode Operation

If the microcontroller is operated with PLL clock mode and no external oscillator is operating or no external clock is supplied, the microcontroller attempts to work with the free oscillating PLL. Performance of this operation, however, cannot be guaranteed.

5. Power Supply Pins (Vcc/Vss)

It is required that all V_{CC}-level as well as all V_{SS}-level power supply pins are at the same potential. If there is more than one V_{CC} or V_{SS} level, the device may operate incorrectly or be damaged even within the guaranteed operating range.

V_{CC} and V_{SS} pins must be connected to the device from the power supply with lowest possible impedance.

The smoothing capacitor at V_{CC} pin must use the one of a capacity value that is larger than C_s.

Besides this, as a measure against power supply noise, it is required to connect a bypass capacitor of about 0.1 μF between V_{CC} and V_{SS} pins as close as possible to V_{CC} and V_{SS} pins.

6. Crystal Oscillator and ceramic resonator Circuit

Noise at X0, X1 pins or X0A, X1A pins might cause abnormal operation. It is required to provide bypass capacitors with shortest possible distance to X0, X1 pins and X0A, X1A pins, crystal oscillator (or ceramic resonator) and ground lines, and, to the utmost effort, that the lines of oscillation circuit do not cross the lines of other circuits.

It is highly recommended to provide a printed circuit board art work surrounding X0, X1 pins and X0A, X1A pins with a ground area for stabilizing the operation.

It is highly recommended to evaluate the quartz/MCU or resonator/MCU system at the quartz or resonator manufacturer, especially when using low-Q resonators at higher frequencies.

7. Turn on Sequence of Power Supply to A/D Converter and Analog Inputs

It is required to turn the A/D converter power supply (AV_{CC}, AVR_H, AVR_L) and analog inputs (AN_n) on after turning the digital power supply (V_{CC}) on.

It is also required to turn the digital power off after turning the A/D converter supply and analog inputs off. In this case, AVR_H must not exceed AV_{CC}. Input voltage for ports shared with analog input ports also must not exceed AV_{CC} (turning the analog and digital power supplies simultaneously on or off is acceptable).

8. Pin Handling when not using the A/D Converter

If the A/D converter is not used, the power supply pins for A/D converter should be connected such as AV_{CC} = V_{CC}, AV_{SS} = AVR_H = AVR_L = V_{SS}.

9. Notes on Power-on

To prevent malfunction of the internal voltage regulator, supply voltage profile while turning the power supply on should be slower than 50 μ s from 0.2V to 2.7V.

10. Stabilization of Power Supply Voltage

If the power supply voltage varies acutely even within the operation safety range of the V_{CC} power supply voltage, a malfunction may occur. The V_{CC} power supply voltage must therefore be stabilized. As stabilization guidelines, the power supply voltage must be stabilized in such a way that V_{CC} ripple fluctuations (peak to peak value) in the commercial frequencies (50Hz to 60Hz) fall within 10% of the standard V_{CC} power supply voltage and the transient fluctuation rate becomes 0.1V/ μ s or less in instantaneous fluctuation for power supply switching.

11. SMC Power Supply Pins

All DV_{CC} / DV_{SS} pins must be set to the same level as the V_{CC} / V_{SS} pins.

Note that the SMC I/O pin state is undefined if DV_{CC} is powered on and V_{CC} is below 3V. To avoid this, V_{CC} must always be powered on before DV_{CC} .

DV_{CC} / DV_{SS} must be applied when using SMC I/O pin as GPIO.

12. Serial Communication

There is a possibility to receive wrong data due to noise or other causes on the serial communication.

Therefore, design a printed circuit board so as to avoid noise.

Consider receiving of wrong data when designing the system. For example apply a checksum and retransmit the data if an error occurs.

13. Mode Pin (MD)

Connect the mode pin directly to V_{CC} or V_{SS} pin. To prevent the device unintentionally entering test mode due to noise, lay out the printed circuit board so as to minimize the distance from the mode pin to V_{CC} or V_{SS} pin and provide a low-impedance connection.

14. Electrical Characteristics

14.1 Absolute Maximum Ratings

Parameter	Symbol	Condition	Rating		Unit	Remarks
			Min	Max		
Power supply voltage* ¹	V _{CC}	-	V _{SS} - 0.3	V _{SS} + 6.0	V	
Analog power supply voltage* ¹	AV _{CC}	-	V _{SS} - 0.3	V _{SS} + 6.0	V	V _{CC} = AV _{CC} * ²
Analog reference voltage* ¹	AVRH, AVRL	-	V _{SS} - 0.3	V _{SS} + 6.0	V	AV _{CC} ≥ AVRH, AV _{CC} ≥ AVRL, AVRH > AVRL, AVRL ≥ AV _{SS}
SMC Power supply* ¹	DV _{CC}	-	V _{SS} - 0.3	V _{SS} + 6.0	V	V _{CC} = AV _{CC} = DV _{CC} * ²
LCD power supply voltage* ¹	V0 to V3	-	V _{SS} - 0.3	V _{SS} + 6.0	V	V0 to V3 must not exceed V _{CC}
Input voltage* ¹	V _I	-	V _{SS} - 0.3	V _{SS} + 6.0	V	V _I ≤ (D)V _{CC} + 0.3V* ³
Output voltage* ¹	V _O	-	V _{SS} - 0.3	V _{SS} + 6.0	V	V _O ≤ (D)V _{CC} + 0.3V* ³
Maximum Clamp Current	I _{CLAMP}	-	-4.0	+4.0	mA	Applicable to general purpose I/O pins * ⁴
Total Maximum Clamp Current	Σ I _{CLAMP}	-	-	32	mA	Applicable to general purpose I/O pins * ⁴
"L" level maximum output current	I _{OLSMC}	I _{OL}	-	15	mA	Normal port
		T _A = -40°C	-	52	mA	High current port
		T _A = +25°C	-	39	mA	
		T _A = +85°C	-	32	mA	
"L" level average output current	I _{OLAVSMC}	I _{OLAV}	-	4	mA	
		T _A = -40°C	-	40	mA	High current port
		T _A = +25°C	-	30	mA	
		T _A = +85°C	-	25	mA	
"L" level maximum overall output current	ΣI _{OLSMC}	ΣI _{OL}	-	62	mA	
		ΣI _{OLAVSMC}	-	300	mA	High current port
"L" level average overall output current	ΣI _{OLAVSMC}	ΣI _{OLAV}	-	31	mA	Normal port
		ΣI _{OLAVSMC}	-	210	mA	High current port
"H" level maximum output current	I _{OHSMC}	I _{OH}	-	-15	mA	Normal port
		T _A = -40°C	-	-52	mA	High current port
		T _A = +25°C	-	-39	mA	
		T _A = +85°C	-	-32	mA	
"H" level average output current	I _{OHAVSMC}	I _{OHAV}	-	-4	mA	
		T _A = -40°C	-	-40	mA	High current port
		T _A = +25°C	-	-30	mA	
		T _A = +85°C	-	-25	mA	
"H" level maximum overall output current	ΣI _{OHSMC}	ΣI _{OH}	-	-62	mA	
		ΣI _{OHSMC}	-	-300	mA	High current port
"H" level average overall output current	ΣI _{OHAVSMC}	ΣI _{OHAV}	-	-31	mA	Normal port
		ΣI _{OHAVSMC}	-	-210	mA	High current port
Power consumption* ⁵	P _D	T _A = +105°C	-	357* ⁶	mW	
Operating ambient temperature	T _A	-	-40	+105	°C	
Storage temperature	T _{STG}	-	-55	+150	°C	

*1: This parameter is based on V_{SS} = AV_{SS} = DV_{SS} = 0V.

*2: AV_{CC} and V_{CC} and DV_{CC} must be set to the same voltage. It is required that AV_{CC} does not exceed V_{CC}, DV_{CC} and that the voltage at the analog inputs does not exceed AV_{CC} when the power is switched on.

*3: V_I and V_O should not exceed V_{CC} + 0.3V. V_I should also not exceed the specified ratings. However if the maximum current to/from an input is limited by some means with external components, the I_{CLAMP} rating supersedes the V_I rating. Input/Output voltages of high current ports depend on DV_{CC}. Input/Output voltages of standard ports depend on V_{CC}.

*4: • Applicable to all general purpose I/O pins (Pnn_m).
• Use within recommended operating conditions.

- Use at DC voltage (current).
- The +B signal should always be applied a limiting resistance placed between the +B signal and the microcontroller.
- The value of the limiting resistance should be set so that when the +B signal is applied the input current to the microcontroller pin does not exceed rated values, either instantaneously or for prolonged periods.
- Note that when the microcontroller drive current is low, such as in the power saving modes, the +B input potential may pass through the protective diode and increase the potential at the V_{CC} pin, and this may affect other devices.
- Note that if a +B signal is input when the microcontroller power supply is off (not fixed at 0V), the power supply is provided from the pins, so that incomplete operation may result.
- Note that if the +B input is applied during power-on, the power supply is provided from the pins and the resulting supply voltage may not be sufficient to operate the Power reset.
- The DEBUG I/F pin has only a protective diode against V_{SS} . Hence it is only permitted to input a negative clamping current (4mA). For protection against positive input voltages, use an external clamping diode which limits the input voltage to maximum 6.0V.

• Sample recommended circuits:

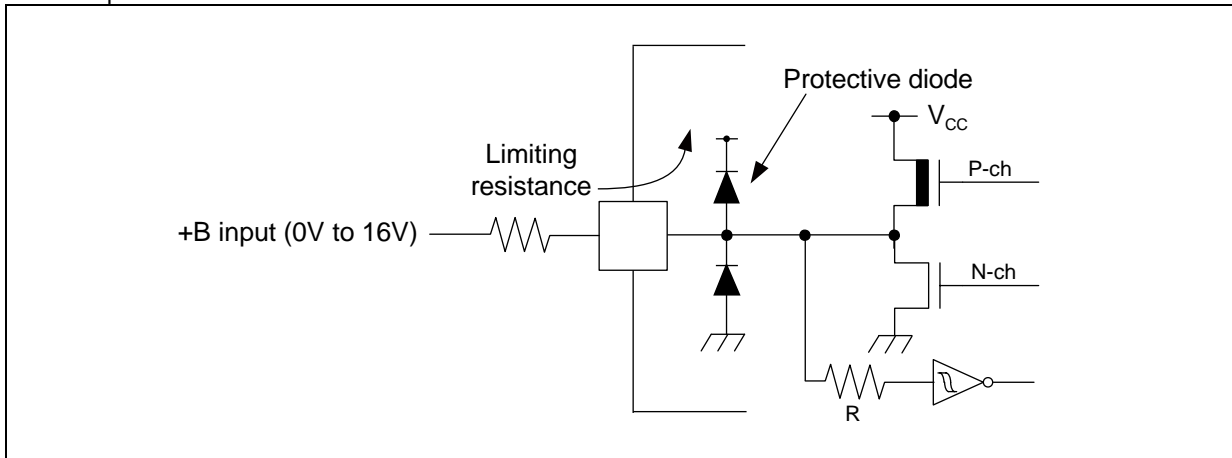

*5: The maximum permitted power dissipation depends on the ambient temperature, the air flow velocity and the thermal conductance of the package on the PCB.

The actual power dissipation depends on the customer application and can be calculated as follows:

$$P_D = P_{IO} + P_{INT}$$

$$P_{IO} = \sum (V_{OL} \times I_{OL} + V_{OH} \times I_{OH}) \text{ (I/O load power dissipation, sum is performed on all I/O ports)}$$

$$P_{INT} = V_{CC} \times (I_{CC} + I_A) \text{ (internal power dissipation)}$$

I_{CC} is the total core current consumption into V_{CC} as described in the “DC characteristics” and depends on the selected operation mode and clock frequency and the usage of functions like Flash programming.

I_A is the analog current consumption into AV_{CC} .

*6: Worst case value for a package mounted on single layer PCB at specified T_A without air flow.

WARNING

Semiconductor devices can be permanently damaged by application of stress (voltage, current, temperature, etc.) in excess of absolute maximum ratings. Do not exceed these ratings.

14.2 Recommended Operating Conditions
 $(V_{SS} = AV_{SS} = DV_{SS} = 0V)$

Parameter	Symbol	Value			Unit	Remarks
		Min	Typ	Max		
Power supply voltage	V_{CC} ,	2.7	-	5.5	V	
	AV_{CC} , DV_{CC}	2.0	-	5.5	V	Maintains RAM data in stop mode
Smoothing capacitor at C pin	C_S	0.5	1.0 to 3.9	4.7	μF	1.0 μF (Allowance within $\pm 50\%$) 3.9 μF (Allowance within $\pm 20\%$) Please use the ceramic capacitor or the capacitor of the frequency response of this level. The smoothing capacitor at V_{CC} must use the one of a capacity value that is larger than C_S .

WARNING

The recommended operating conditions are required in order to ensure the normal operation of the semiconductor device. All of the device's electrical characteristics are warranted when the device is operated within these ranges.

Always use semiconductor devices within their recommended operating condition ranges. Operation outside these ranges may adversely affect reliability and could result in device failure. No warranty is made with respect to uses, operating conditions, or combinations not represented on the data sheet. Users considering application outside the listed conditions are advised to contact their representatives beforehand.

14.3 DC Characteristics
14.3.1 Current Rating
(V_{CC} = AV_{CC} = DV_{CC} = 2.7V to 5.5V, V_{SS} = AV_{SS} = DV_{SS} = 0V, T_A = - 40°C to + 105°C)

Parameter	Symbol	Pin Name	Conditions	Value			Unit	Remarks
				Min	Typ	Max		
Power supply current in Run modes ^{*1}	I _{CCPLL}	V _{CC}	PLL Run mode with CLKS1/2 = CLKB = CLKP1/2 = 32MHz	-	28	-	mA	T _A = +25°C
			Flash 0 wait (CLKRC and CLKSC stopped)	-	-	38	mA	T _A = +105°C
	I _{CCMAIN}		Main Run mode with CLKS1/2 = CLKB = CLKP1/2 = 4MHz	-	3.5	-	mA	T _A = +25°C
			Flash 0 wait (CLKPLL, CLKSC and CLKRC stopped)	-	-	8	mA	T _A = +105°C
	I _{CCRCH}		RC Run mode with CLKS1/2 = CLKB = CLKP1/2 = CLKRC = 2MHz	-	1.8	-	mA	T _A = +25°C
			Flash 0 wait (CLKMC, CLKPLL and CLKSC stopped)	-	-	6	mA	T _A = +105°C
	I _{CCRCL}		RC Run mode with CLKS1/2 = CLKB = CLKP1/2 = CLKRC = 100kHz	-	0.16	-	mA	T _A = +25°C
			Flash 0 wait (CLKMC, CLKPLL and CLKSC stopped)	-	-	3.5	mA	T _A = +105°C
	I _{CCSUB}		Sub Run mode with CLKS1/2 = CLKB = CLKP1/2 = 32kHz	-	0.1	-	mA	T _A = +25°C
			Flash 0 wait (CLKMC, CLKPLL and CLKRC stopped)	-	-	3.3	mA	T _A = +105°C

Parameter	Symbol	Pin Name	Conditions	Value			Unit	Remarks	
				Min	Typ	Max			
Power supply current in Sleep modes ¹	I _{CCSPLL}	V _{CC}	PLL Sleep mode with CLK _{S1/2} = CLK _{P1/2} = 32MHz (CLK _{RC} and CLK _{SC} stopped)	-	9.5	-	mA	T _A = +25°C	
			-	-	15	mA	T _A = +105°C		
	I _{CCSMAN}		Main Sleep mode with CLK _{S1/2} = CLK _{P1/2} = 4MHz, SMCR:LPMSS = 0 (CLK _{PLL} , CLK _{RC} and CLK _{SC} stopped)	-	1.1	-	mA	T _A = +25°C	
			-	-	4.7	mA	T _A = +105°C		
	I _{CCSRCH}		RC Sleep mode with CLK _{S1/2} = CLK _{P1/2} = CLK _{RC} = 2MHz, SMCR:LPMSS = 0 (CLK _{MC} , CLK _{PLL} and CLK _{SC} stopped)	-	0.6	-	mA	T _A = +25°C	
			-	-	4.1	mA	T _A = +105°C		
	I _{CCSRCL}		RC Sleep mode with CLK _{S1/2} = CLK _{P1/2} = CLK _{RC} = 100kHz (CLK _{MC} , CLK _{PLL} and CLK _{SC} stopped)	-	0.07	-	mA	T _A = +25°C	
			-	-	2.9	mA	T _A = +105°C		
	I _{CCSSUB}		Sub Sleep mode with CLK _{S1/2} = CLK _{P1/2} = 32kHz, (CLK _{MC} , CLK _{PLL} and CLK _{RC} stopped)	-	0.04	-	mA	T _A = +25°C	
			-	-	2.7	mA	T _A = +105°C		
	Power supply current in Timer modes ²		I _{CCTPLL}	PLL Timer mode with CLK _{PLL} = 32MHz (CLK _{RC} and CLK _{SC} stopped)	-	1800	2250	μA	T _A = +25°C
				-	-	3220	μA	T _A = +105°C	
I _{CCTMAIN}		Main Timer mode with CLK _{MC} = 4MHz, SMCR:LPMSS = 0 (CLK _{PLL} , CLK _{RC} and CLK _{SC} stopped)	-	285	330	μA	T _A = +25°C		
		-	-	1200	μA	T _A = +105°C			
I _{CCTRCH}		RC Timer mode with CLK _{RC} = 2MHz, SMCR:LPMSS = 0 (CLK _{PLL} , CLK _{MC} and CLK _{SC} stopped)	-	160	215	μA	T _A = +25°C		
		-	-	1110	μA	T _A = +105°C			
I _{CCTRCL}		RC Timer mode with CLK _{RC} = 100kHz (CLK _{PLL} , CLK _{MC} and CLK _{SC} stopped)	-	35	75	μA	T _A = +25°C		
		-	-	910	μA	T _A = +105°C			
I _{CCTSUB}		Sub Timer mode with CLK _{SC} = 32kHz (CLK _{MC} , CLK _{PLL} and CLK _{RC} stopped)	-	25	65	μA	T _A = +25°C		
		-	-	885	μA	T _A = +105°C			

Parameter	Symbol	Pin Name	Conditions	Value			Unit	Remarks
				Min	Typ	Max		
Power supply current in Stop mode*3	I _{CCH}	V _{CC}	-	-	20	60	μA	T _A = +25°C
				-	-	880	μA	T _A = +105°C
Flash Power Down current	I _{CCFLASHPD}		-	-	36	70	μA	
Power supply current for active Low Voltage detector*4	I _{CCCLVD}		Low voltage detector enabled	-	5	-	μA	T _A = +25°C
				-	-	12.5	μA	T _A = +105°C
Flash Write/ Erase current**5	I _{CCFLASH}		-	-	12.5	-	mA	T _A = +25°C
		-		-	20	mA	T _A = +105°C	

*1: The power supply current is measured with a 4MHz external clock connected to the Main oscillator and a 32kHz external clock connected to the Sub oscillator. See chapter "Standby mode and voltage regulator control circuit" of the Hardware Manual for further details about voltage regulator control. Current for "On Chip Debugger" part is not included. Power supply current in Run mode does not include Flash Write / Erase current.

*2: The power supply current in Timer mode is the value when Flash is in Power-down / reset mode. When Flash is not in Power-down / reset mode, I_{CCFLASHPD} must be added to the Power supply current. The power supply current is measured with a 4MHz external clock connected to the Main oscillator and a 32kHz external clock connected to the Sub oscillator. The current for "On Chip Debugger" part is not included.

*3: The power supply current in Stop mode is the value when Flash is in Power-down / reset mode. When Flash is not in Power-down / reset mode, I_{CCFLASHPD} must be added to the Power supply current.

*4: When low voltage detector is enabled, I_{CCCLVD} must be added to Power supply current.

*5: When Flash Write / Erase program is executed, I_{CCFLASH} must be added to Power supply current.

14.3.2 Pin Characteristics
 $(V_{CC} = AV_{CC} = DV_{CC} = 2.7V \text{ to } 5.5V, V_{SS} = AV_{SS} = DV_{SS} = 0V, T_A = -40^{\circ}C \text{ to } +105^{\circ}C)$

Parameter	Symbol	Pin Name	Conditions	Value			Unit	Remarks
				Min	Typ	Max		
"H" level input voltage	V_{IH}	Port inputs Pnn_m	-	$V_{CC} \times 0.7$	-	$V_{CC} + 0.3$	V	CMOS Hysteresis input
			-	$V_{CC} \times 0.8$	-	$V_{CC} + 0.3$	V	AUTOMOTIVE Hysteresis input
	V_{IHx0S}	X0	External clock in "Fast Clock Input mode"	$VD \times 0.8$	-	VD	V	VD=1.8V±0.15V
	V_{IHx0AS}	X0A	External clock in "Oscillation mode"	$V_{CC} \times 0.8$	-	$V_{CC} + 0.3$	V	
	V_{IHR}	RSTX	-	$V_{CC} \times 0.8$	-	$V_{CC} + 0.3$	V	CMOS Hysteresis input
	V_{IHM}	MD	-	$V_{CC} - 0.3$	-	$V_{CC} + 0.3$	V	CMOS Hysteresis input
	V_{IHD}	DEBUG I/F	-	2.0	-	$V_{CC} + 0.3$	V	TTL Input
"L" level input voltage	V_{IL}	Port inputs Pnn_m	-	$V_{SS} - 0.3$	-	$V_{CC} \times 0.3$	V	CMOS Hysteresis input
			-	$V_{SS} - 0.3$	-	$V_{CC} \times 0.5$	V	AUTOMOTIVE Hysteresis input
	V_{ILx0S}	X0	External clock in "Fast Clock Input mode"	V_{SS}	-	$VD \times 0.2$	V	VD=1.8V±0.15V
	V_{ILx0AS}	X0A	External clock in "Oscillation mode"	$V_{SS} - 0.3$	-	$V_{CC} \times 0.2$	V	
	V_{ILR}	RSTX	-	$V_{SS} - 0.3$	-	$V_{CC} \times 0.2$	V	CMOS Hysteresis input
	V_{ILM}	MD	-	$V_{SS} - 0.3$	-	$V_{SS} + 0.3$	V	CMOS Hysteresis input
	V_{ILD}	DEBUG I/F	-	$V_{SS} - 0.3$	-	0.8	V	TTL Input

Parameter	Symbol	Pin Name	Conditions	Value			Unit	Remarks	
				Min	Typ	Max			
"H" level output voltage	V _{OH4}	4mA type	4.5V ≤ (D)V _{CC} ≤ 5.5V I _{OH} = -4mA	(D)V _{CC} - 0.5	-	(D)V _{CC}	V		
			2.7V ≤ (D)V _{CC} < 4.5V I _{OH} = -1.5mA						
	V _{OH30}	High Drive type	4.5V ≤ DV _{CC} ≤ 5.5V I _{OH} = -52mA	DV _{CC} - 0.5	-	DV _{CC}	V		T _A = -40°C
			2.7V ≤ DV _{CC} < 4.5V I _{OH} = -18mA						
			4.5V ≤ DV _{CC} ≤ 5.5V I _{OH} = -39mA						
			2.7V ≤ DV _{CC} < 4.5V I _{OH} = -16mA						
			4.5V ≤ DV _{CC} ≤ 5.5V I _{OH} = -32mA						
			2.7V ≤ DV _{CC} < 4.5V I _{OH} = -14.5mA						
			4.5V ≤ DV _{CC} ≤ 5.5V I _{OH} = -30mA						
			2.7V ≤ DV _{CC} < 4.5V I _{OH} = -14mA						
	V _{OH3}	3mA type	4.5V ≤ V _{CC} ≤ 5.5V I _{OH} = -3mA	V _{CC} - 0.5	-	V _{CC}	V		T _A = +25°C
			2.7V ≤ V _{CC} < 4.5V I _{OH} = -1.5mA						
"L" level output voltage	V _{OL4}	4mA type	4.5V ≤ (D)V _{CC} ≤ 5.5V I _{OL} = +4mA	-	-	0.4	V		
			2.7V ≤ (D)V _{CC} < 4.5V I _{OL} = +1.7mA						
	V _{OL30}	High Drive type	4.5V ≤ DV _{CC} ≤ 5.5V I _{OL} = +52mA	-	-	0.5	V		T _A = -40°C
			2.7V ≤ DV _{CC} < 4.5V I _{OL} = +22mA						
			4.5V ≤ DV _{CC} ≤ 5.5V I _{OL} = +39mA						
			2.7V ≤ DV _{CC} < 4.5V I _{OL} = +18mA						
			4.5V ≤ DV _{CC} ≤ 5.5V I _{OL} = +32mA						
			2.7V ≤ DV _{CC} < 4.5V I _{OL} = +14mA						
			4.5V ≤ DV _{CC} ≤ 5.5V I _{OL} = +30mA						
			2.7V ≤ DV _{CC} < 4.5V I _{OL} = +13.5mA						
	V _{OL3}	3mA type	2.7V ≤ V _{CC} < 5.5V I _{OL} = +3mA	-	-	0.4	V		T _A = +25°C
	V _{OLD}	DEBUG I/F	V _{CC} = 2.7V I _{OL} = +25mA	0	-	0.25	V		T _A = +85°C
							T _A = +105°C		

Parameter	Symbol	Pin Name	Conditions	Value			Unit	Remarks
				Min	Typ	Max		
Input leak current	I_{IL}	Pnn_m	$V_{SS} < V_I < V_{CC}$ $AV_{SS}, AV_{RL} < V_I < AV_{CC}, AV_{RH}$	- 1	-	+ 1	μA	Single port pin except high current output I/O for SMC
		P08_m, P09_m, P10_m	$DV_{SS} < V_I < DV_{CC}$ $AV_{SS}, AV_{RL} < V_I < AV_{CC}, AV_{RH}$	- 3	-	+ 3	μA	
Total LCD leak current	$\Sigma I_{LCD} $	All SEG/ COM pin	$V_{CC} = 5.0V$	-	0.5	10	μA	Maximum leakage current of all LCD pins
Internal LCD divide resistance	R_{LCD}	Between V3 and V2, V2 and V1, V1 and V0	$V_{CC} = 5.0V$	6.25	12.5	25	$k\Omega$	
Pull-up resistance value	R_{PU}	Pnn_m	$V_{CC} = 5.0V \pm 10\%$	25	50	100	$k\Omega$	
Pull-down resistance value	R_{DOWN}	P08_m, P09_m, P10_m	$V_{CC} = 5.0V \pm 10\%$	25	50	100	$k\Omega$	
Input capacitance	C_{IN}	Other than C, Vcc, Vss, DVcc, DVss, AVcc, AVss, AVRH, AVRL, P08_m, P09_m, P10_m	-	-	5	15	pF	
		P08_m, P09_m, P10_m	-	-	15	30	pF	

*: In the case of driving stepping motor directly or high current outputs, set "1" to the bit in the Port High Drive Register (PHDRnn:HDx="1").

14.4 AC Characteristics

14.4.1 Main Clock Input Characteristics

($V_{CC} = AV_{CC} = DV_{CC} = 2.7V$ to $5.5V$, $V_D = 1.8V \pm 0.15V$, $V_{SS} = AV_{SS} = DV_{SS} = 0V$, $T_A = -40^\circ C$ to $+105^\circ C$)

Parameter	Symbol	Pin Name	Value			Unit	Remarks
			Min	Typ	Max		
Input frequency	f_c	X0, X1	4	-	8	MHz	When using a crystal oscillator, PLL off
			-	-	8	MHz	When using an opposite phase external clock, PLL off
			4	-	8	MHz	When using a crystal oscillator or opposite phase external clock, PLL on
Input frequency	f_{FCI}	X0	-	-	8	MHz	When using a single phase external clock in "Fast Clock Input mode", PLL off
			4	-	8	MHz	When using a single phase external clock in "Fast Clock Input mode", PLL on
Input clock cycle	t_{CYLH}	-	125	-	-	ns	
Input clock pulse width	P_{WH}, P_{WL}	-	55	-	-	ns	

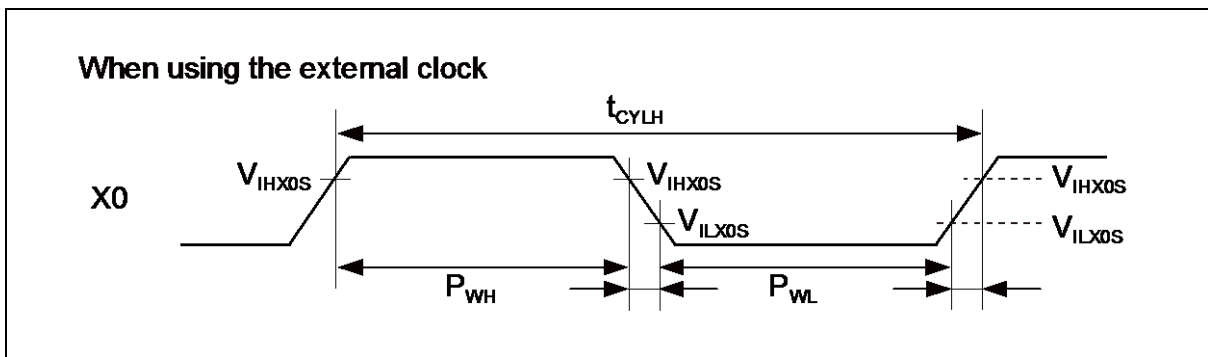
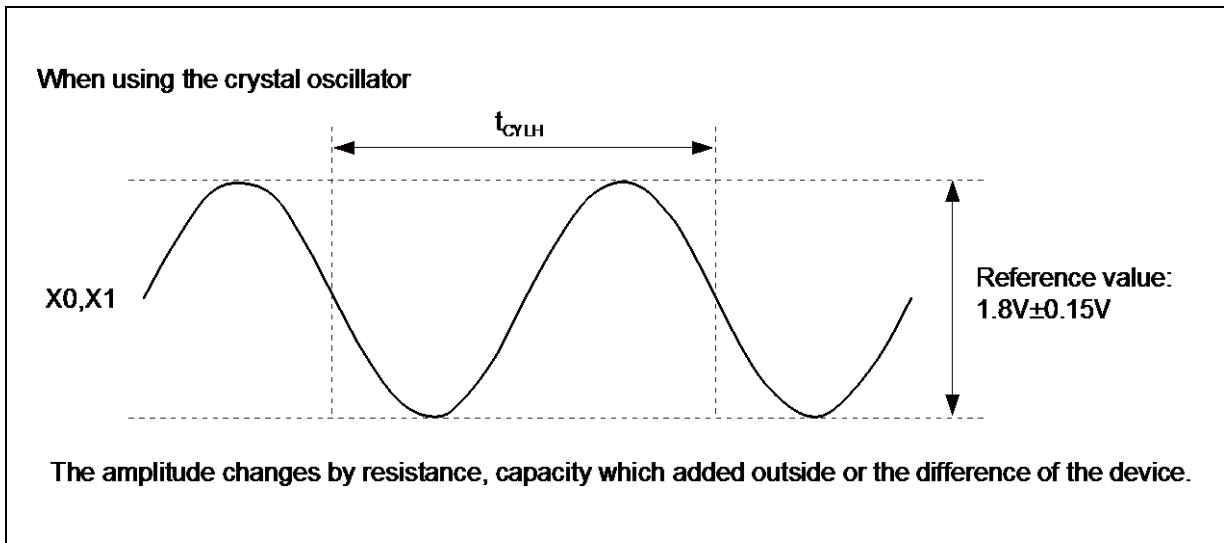

14.4.2 Sub Clock Input Characteristics

($V_{CC} = AV_{CC} = DV_{CC} = 2.7V$ to $5.5V$, $V_{SS} = AV_{SS} = DV_{SS} = 0V$, $T_A = -40^{\circ}C$ to $+105^{\circ}C$)

Parameter	Symbol	Pin Name	Conditions	Value			Unit	Remarks
				Min	Typ	Max		
Input frequency	f_{CL}	X0A, X1A	-	-	32.768	-	kHz	When using an oscillation circuit
			-	-	-	100		kHz
		X0A	-	-	-	50	kHz	When using a single phase external clock
Input clock cycle	t_{CYLL}	-	-	10	-	-	μs	
Input clock pulse width	-	-	P_{WH}/t_{CYLL} , P_{WL}/t_{CYLL}	30	-	70	%	

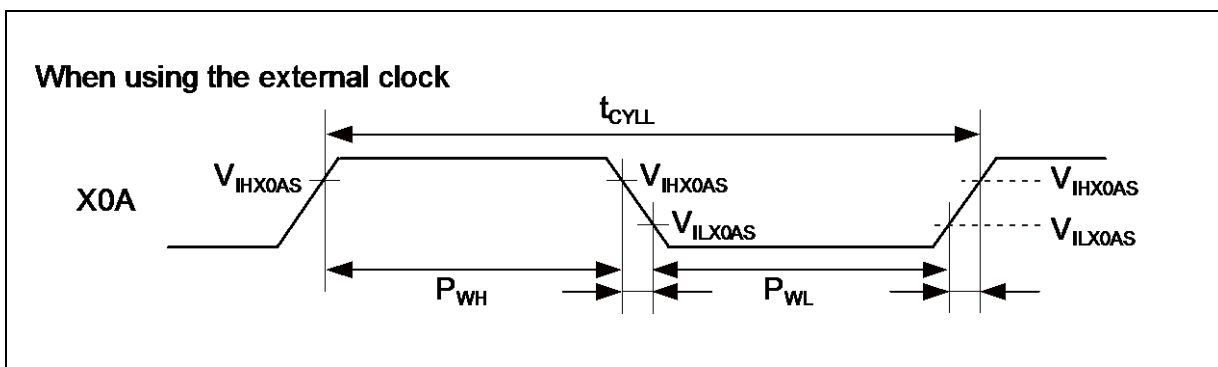
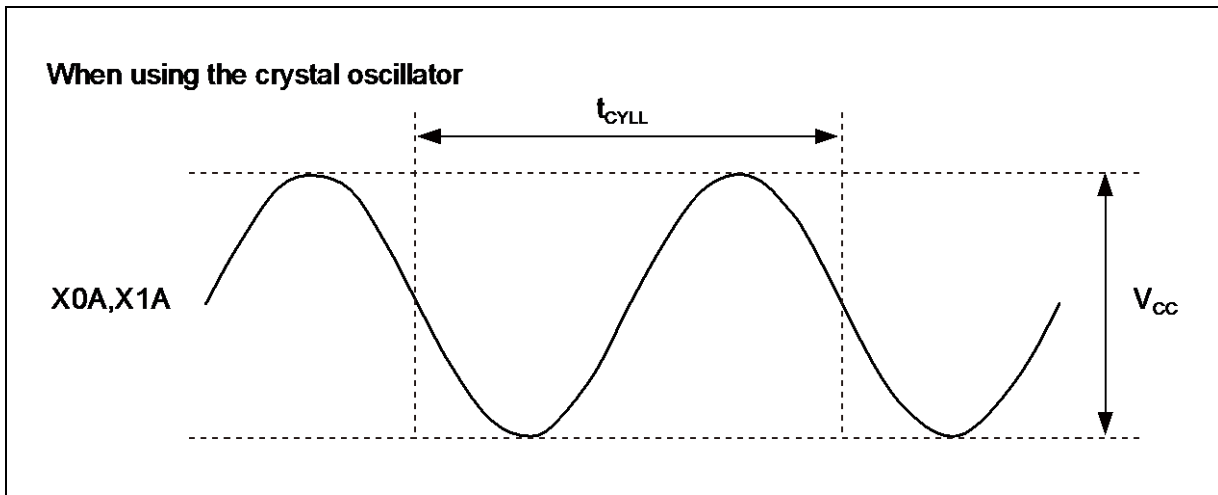

14.4.3 Built-in RC Oscillation Characteristics

($V_{CC} = AV_{CC} = DV_{CC} = 2.7V$ to $5.5V$, $V_{SS} = AV_{SS} = DV_{SS} = 0V$, $T_A = -40^{\circ}C$ to $+105^{\circ}C$)

Parameter	Symbol	Value			Unit	Remarks
		Min	Typ	Max		
Clock frequency	f_{RC}	50	100	200	kHz	When using slow frequency of RC oscillator
		1	2	4	MHz	When using fast frequency of RC oscillator
RC clock stabilization time	t_{RCSTAB}	80	160	320	μs	When using slow frequency of RC oscillator (16 RC clock cycles)
		64	128	256	μs	When using fast frequency of RC oscillator (256 RC clock cycles)

14.4.4 Internal Clock Timing

($V_{CC} = AV_{CC} = DV_{CC} = 2.7V$ to $5.5V$, $V_{SS} = AV_{SS} = DV_{SS} = 0V$, $T_A = -40^{\circ}C$ to $+105^{\circ}C$)

Parameter	Symbol	Value		Unit
		Min	Max	
Internal System clock frequency (CLKS1 and CLKS2)	f_{CLKS1}, f_{CLKS2}	-	54	MHz
Internal CPU clock frequency (CLKB), Internal peripheral clock frequency (CLKP1)	f_{CLKB}, f_{CLKP1}	-	32	MHz
Internal peripheral clock frequency (CLKP2)	f_{CLKP2}	-	32	MHz

14.4.5 Operating Conditions of PLL

($V_{CC} = AV_{CC} = DV_{CC} = 2.7V$ to $5.5V$, $V_{SS} = AV_{SS} = DV_{SS} = 0V$, $T_A = -40^{\circ}C$ to $+105^{\circ}C$)

Parameter	Symbol	Value			Unit	Remarks
		Min	Typ	Max		
PLL oscillation stabilization wait time	t_{LOCK}	1	-	4	ms	For CLKMC = 4MHz
PLL input clock frequency	f_{PLLI}	4	-	8	MHz	
PLL oscillation clock frequency	f_{CLKVCO}	56	-	108	MHz	Permitted VCO output frequency of PLL (CLKVCO)
PLL phase jitter	t_{PSKEW}	-5	-	+5	ns	For CLKMC (PLL input clock) \geq 4MHz

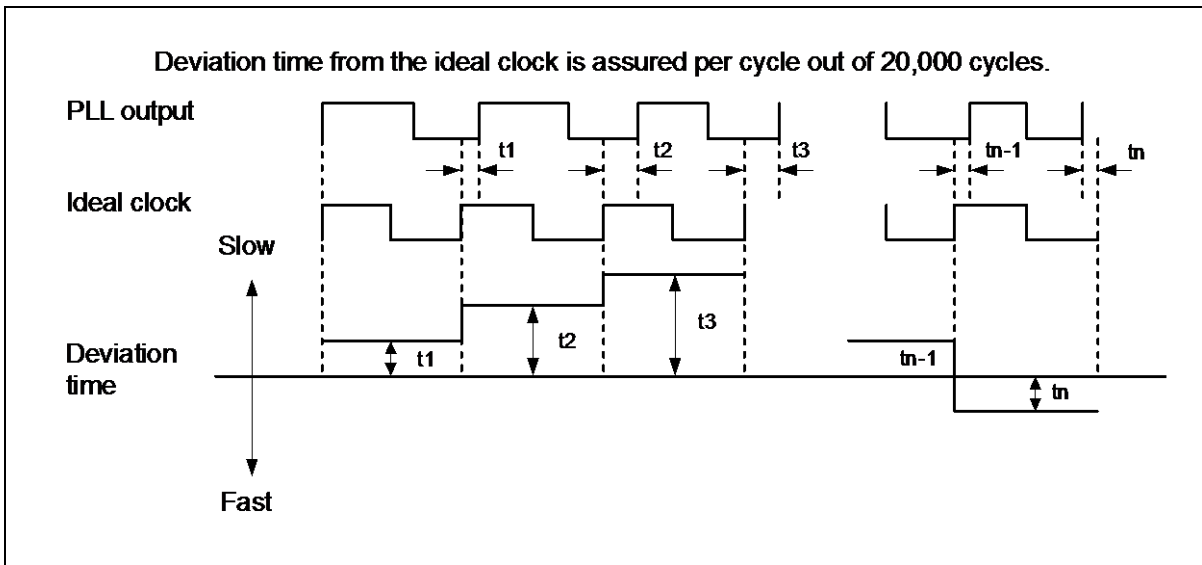

14.4.6 Reset Input

($V_{CC} = AV_{CC} = DV_{CC} = 2.7V$ to $5.5V$, $V_{SS} = AV_{SS} = DV_{SS} = 0V$, $T_A = -40^{\circ}C$ to $+105^{\circ}C$)

Parameter	Symbol	Pin Name	Value		Unit
			Min	Max	
Reset input time	t_{RSTL}	RSTX	10	-	μS
Rejection of reset input time			1	-	μS

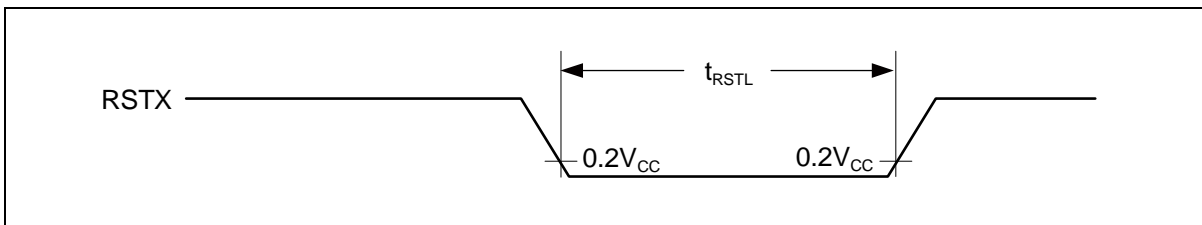

14.4.7 Power-on Reset Timing

($V_{CC} = AV_{CC} = DV_{CC} = 2.7V$ to $5.5V$, $V_{SS} = AV_{SS} = DV_{SS} = 0V$, $T_A = -40^{\circ}C$ to $+105^{\circ}C$)

Parameter	Symbol	Pin Name	Value			Unit
			Min	Typ	Max	
Power on rise time	t_R	Vcc	0.05	-	30	ms
Power off time	t_{OFF}	Vcc	1	-	-	ms

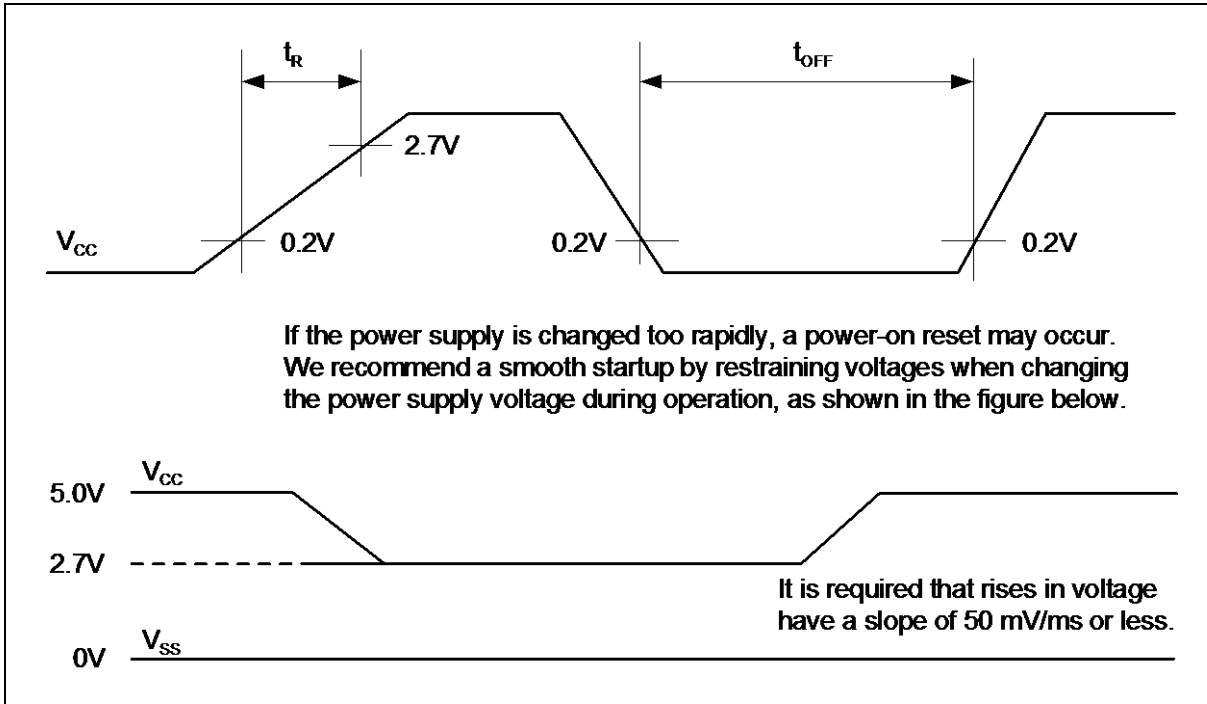

14.4.8 USART Timing
 $(V_{CC} = AV_{CC} = DV_{CC} = 2.7V \text{ to } 5.5V, V_{SS} = AV_{SS} = DV_{SS} = 0V, T_A = -40^\circ C \text{ to } +105^\circ C, C_L = 50pF)$

Parameter	Symbol	Pin Name	Conditions	4.5V ≤ V _{CC} < 5.5V		2.7V ≤ V _{CC} < 4.5V		Unit
				Min	Max	Min	Max	
Serial clock cycle time	t _{SCYC}	SCKn	Internal shift clock mode	4t _{CLKP1}	-	4t _{CLKP1}	-	ns
SCK ↓ → SOT delay time	t _{SLOVI}	SCKn, SOTn		- 20	+ 20	- 30	+ 30	ns
SOT → SCK ↑ delay time	t _{OVSHI}	SCKn, SOTn		N × t _{CLKP1} - 20*	-	N × t _{CLKP1} - 30*	-	ns
SIN → SCK ↑ setup time	t _{IVSHI}	SCKn, SINn		t _{CLKP1} + 45	-	t _{CLKP1} + 55	-	ns
SCK ↑ → SIN hold time	t _{SHIXI}	SCKn, SINn		0	-	0	-	ns
Serial clock "L" pulse width	t _{LSLH}	SCKn	External shift clock mode	t _{CLKP1} + 10	-	t _{CLKP1} + 10	-	ns
Serial clock "H" pulse width	t _{SHSL}	SCKn		t _{CLKP1} + 10	-	t _{CLKP1} + 10	-	ns
SCK ↓ → SOT delay time	t _{SLOVE}	SCKn, SOTn		-	2t _{CLKP1} + 45	-	2t _{CLKP1} + 55	ns
SIN → SCK ↑ setup time	t _{IVSHE}	SCKn, SINn		t _{CLKP1} /2 + 10	-	t _{CLKP1} /2 + 10	-	ns
SCK ↑ → SIN hold time	t _{SHIXE}	SCKn, SINn		t _{CLKP1} + 10	-	t _{CLKP1} + 10	-	ns
SCK fall time	t _F	SCKn		-	20	-	20	ns
SCK rise time	t _R	SCKn		-	20	-	20	ns

- Notes:
- AC characteristic in CLK synchronized mode.
 - C_L is the load capacity value of pins when testing.
 - Depending on the used machine clock frequency, the maximum possible baud rate can be limited by some parameters. These parameters are shown in "CY96600 series HARDWARE MANUAL".
 - t_{CLKP1} indicates the peripheral clock 1 (CLKP1), Unit: ns
 - These characteristics only guarantee the same relocate port number.
For example, the combination of SCKn and SOTn_R is not guaranteed.

- *: Parameter N depends on t_{SCYC} and can be calculated as follows:
- If t_{SCYC} = 2 × k × t_{CLKP1}, then N = k, where k is an integer > 2
 - If t_{SCYC} = (2 × k + 1) × t_{CLKP1}, then N = k + 1, where k is an integer > 1

Examples:

t _{SCYC}	N
4 × t _{CLKP1}	2
5 × t _{CLKP1} , 6 × t _{CLKP1}	3
7 × t _{CLKP1} , 8 × t _{CLKP1}	4
...	...

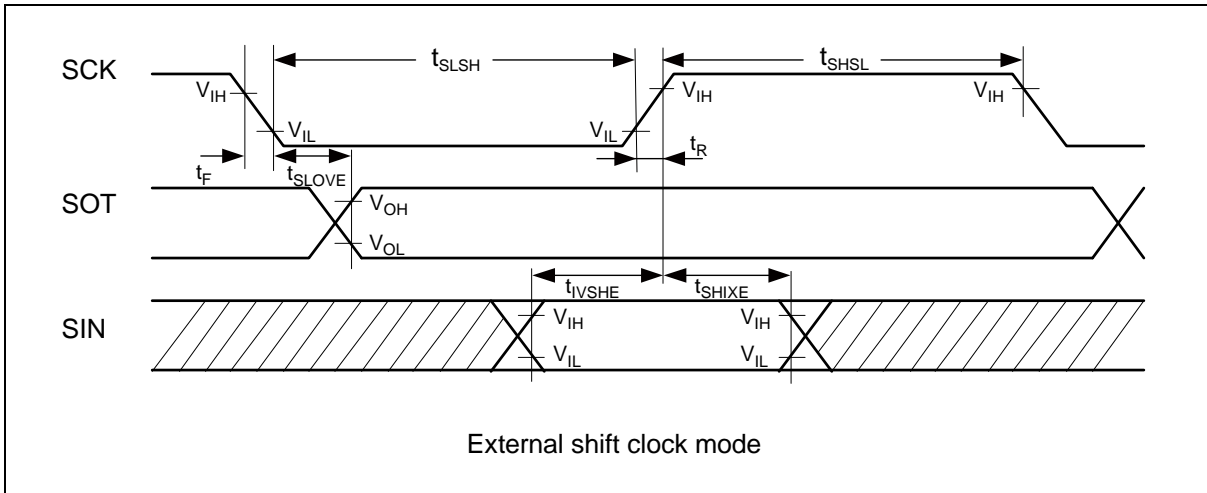
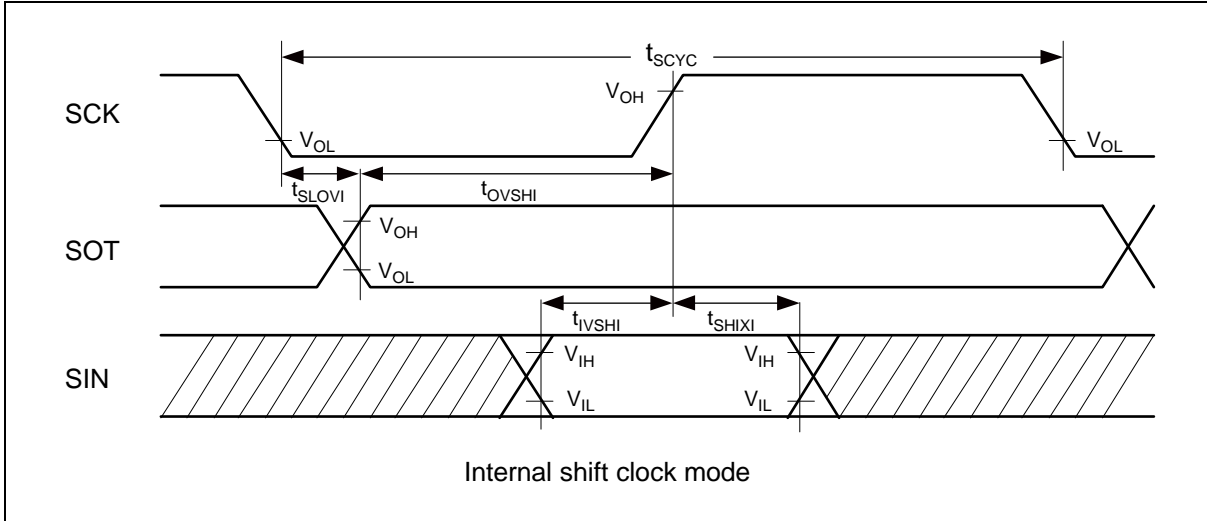

14.4.9 External Input Timing

($V_{CC} = AV_{CC} = DV_{CC} = 2.7V$ to $5.5V$, $V_{SS} = AV_{SS} = DV_{SS} = 0V$, $T_A = -40^{\circ}C$ to $+105^{\circ}C$)

Parameter	Symbol	Pin Name	Value		Unit	Remarks
			Min	Max		
Input pulse width	t_{INH} , t_{INL}	Pnn_m	$2t_{CLKP1} + 200$ ($t_{CLKP1} = 1/f_{CLKP1}$)*	-	ns	General Purpose I/O
		ADTG				A/D Converter trigger input
		TINn, TINn_R				Reload Timer
		TTGn				PPG trigger input
		FRCKn, FRCKn_R				Free-Running Timer input clock
		INn, INn_R				Input Capture
		INTn, INTn_R	External Interrupt			
		NMI	Non-Maskable Interrupt			
				200	-	ns

*: t_{CLKP1} indicates the peripheral clock1 (CLKP1) cycle time except stop when in stop mode.

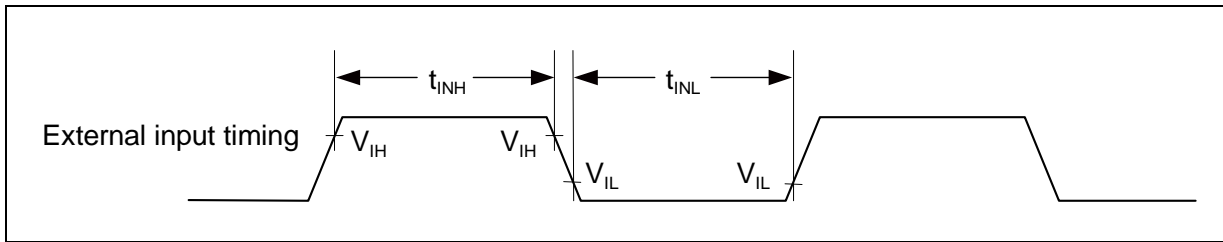

14.4.10 I²C Timing
 $(V_{CC} = AV_{CC} = DV_{CC} = 2.7V \text{ to } 5.5V, V_{SS} = AV_{SS} = DV_{SS} = 0V, T_A = -40^{\circ}C \text{ to } +105^{\circ}C)$

Parameter	Symbol	Conditions	Typical Mode		High-Speed Mode ^{*4}		Unit
			Min	Max	Min	Max	
SCL clock frequency	f_{SCL}		0	100	0	400	kHz
(Repeated) START condition hold time SDA ↓ → SCL ↓	t_{HDSTA}		4.0	-	0.6	-	μs
SCL clock "L" width	t_{LOW}		4.7	-	1.3	-	μs
SCL clock "H" width	t_{HIGH}		4.0	-	0.6	-	μs
(Repeated) START condition setup time SCL ↑ → SDA ↓	t_{SUSTA}		4.7	-	0.6	-	μs
Data hold time SCL ↓ → SDA ↓ ↑	t_{HDDAT}	$C_L = 50pF,$ $R = (V_p/I_{OL})^{*1}$	0	3.45^{*2}	0	0.9^{*3}	μs
Data setup time SDA ↓ ↑ → SCL ↑	t_{SUDAT}		250	-	100	-	ns
STOP condition setup time SCL ↑ → SDA ↑	t_{SUSTO}		4.0	-	0.6	-	μs
Bus free time between "STOP condition" and "START condition"	t_{BUS}		4.7	-	1.3	-	μs
Pulse width of spikes which will be suppressed by input noise filter	t_{SP}	-	0	$(1-1.5) \times$ t_{CLKP1}^{*5}	0	$(1-1.5) \times$ t_{CLKP1}^{*5}	ns

*1: R and C_L represent the pull-up resistance and load capacitance of the SCL and SDA lines, respectively.

V_p indicates the power supply voltage of the pull-up resistance and I_{OL} indicates V_{OL} guaranteed current.

*2: The maximum t_{HDDAT} only has to be met if the device does not extend the "L" width (t_{LOW}) of the SCL signal.

*3: A high-speed mode I²C bus device can be used on a standard mode I²C bus system as long as the device satisfies the requirement of "t_{SUDAT} ≥ 250ns".

*4: For use at over 100kHz, set the peripheral clock1 (CLKP1) to at least 6MHz.

*5: t_{CLKP1} indicates the peripheral clock1 (CLKP1) cycle time.

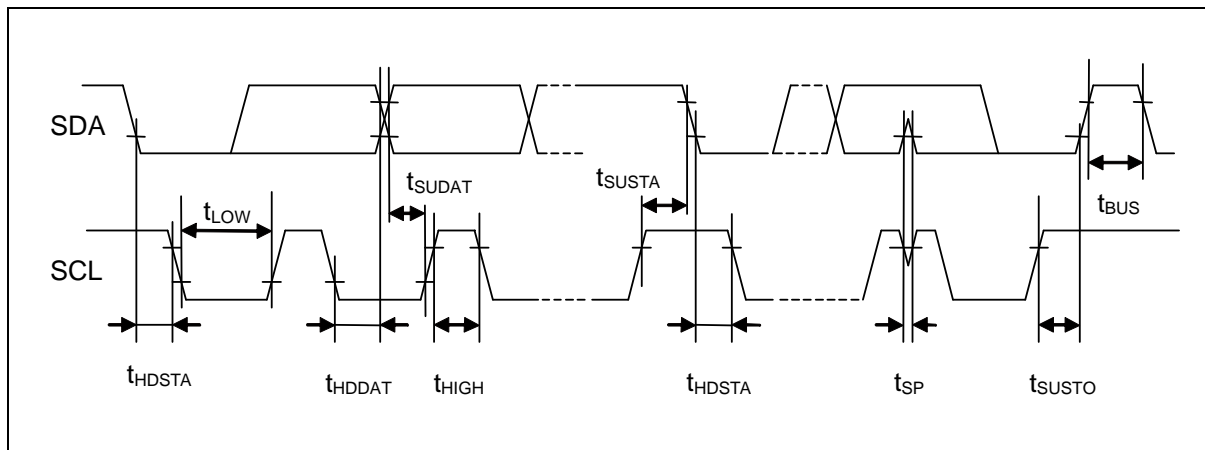

14.5 A/D Converter
14.5.1 Electrical Characteristics for the A/D Converter

 (V_{CC} = AV_{CC} = DV_{CC} = 2.7V to 5.5V, V_{SS} = AV_{SS} = DV_{SS} = 0V, T_A = - 40°C to + 105°C)

Parameter	Symbol	Pin Name	Value			Unit	Remarks
			Min	Typ	Max		
Resolution	-	-	-	-	10	bit	
Total error	-	-	- 3.0	-	+ 3.0	LSB	
Nonlinearity error	-	-	- 2.5	-	+ 2.5	LSB	
Differential Nonlinearity error	-	-	- 1.9	-	+ 1.9	LSB	
Zero transition voltage	V _{OT}	ANn	Typ - 20	AVRL + 0.5LSB	Typ + 20	mV	
Full scale transition voltage	V _{FST}	ANn	Typ - 20	AVRH - 1.5LSB	Typ + 20	mV	
Compare time*	-	-	1.0	-	5.0	μs	4.5V ≤ AV _{CC} ≤ 5.5V
			2.2	-	8.0	μs	2.7V ≤ AV _{CC} < 4.5V
Sampling time*	-	-	0.5	-	-	μs	4.5V ≤ AV _{CC} ≤ 5.5V
			1.2	-	-	μs	2.7V ≤ AV _{CC} < 4.5V
Power supply current	I _A	AV _{CC}	-	2.0	3.1	mA	A/D Converter active
	I _{AH}		-	-	3.3	μA	A/D Converter not operated
Reference power supply current (between AVRH and AVRL)	I _R	AVRH	-	520	810	μA	A/D Converter active
	I _{RH}		-	-	1.0	μA	A/D Converter not operated
Analog input capacity	C _{VIN}	AN0 to 15	-	-	16.0	pF	Normal outputs
		AN16 to 31	-	-	17.8	pF	High current outputs
Analog impedance	R _{VIN}	ANn	-	-	2050	Ω	4.5V ≤ AV _{CC} ≤ 5.5V
			-	-	3600	Ω	2.7V ≤ AV _{CC} < 4.5V
Analog port input current (during conversion)	I _{AIN}	AN0 to 15	- 0.3	-	+ 0.3	μA	AV _{SS} , AVRL < V _{AIN} < AV _{CC} , AVRH
		AN16 to 31	- 3.0	-	+ 3.0	μA	
Analog input voltage	V _{AIN}	ANn	AVRL	-	AVRH	V	
Reference voltage range	-	AVRH	AV _{CC} - 0.1	-	AV _{CC}	V	
		AVRL	AV _{SS}	-	AV _{SS} + 0.1	V	
Variation between channels	-	ANn	-	-	4.0	LSB	

*: Time for each channel.

14.5.2 Accuracy and Setting of the A/D Converter Sampling Time

If the external impedance is too high or the sampling time too short, the analog voltage charged to the internal sample and hold capacitor is insufficient, adversely affecting the A/D conversion precision.

To satisfy the A/D conversion precision, a sufficient sampling time must be selected. The required sampling time (T_{samp}) depends on the external driving impedance R_{ext} , the board capacitance of the A/D converter input pin C_{ext} and the AV_{CC} voltage level. The following replacement model can be used for the calculation:

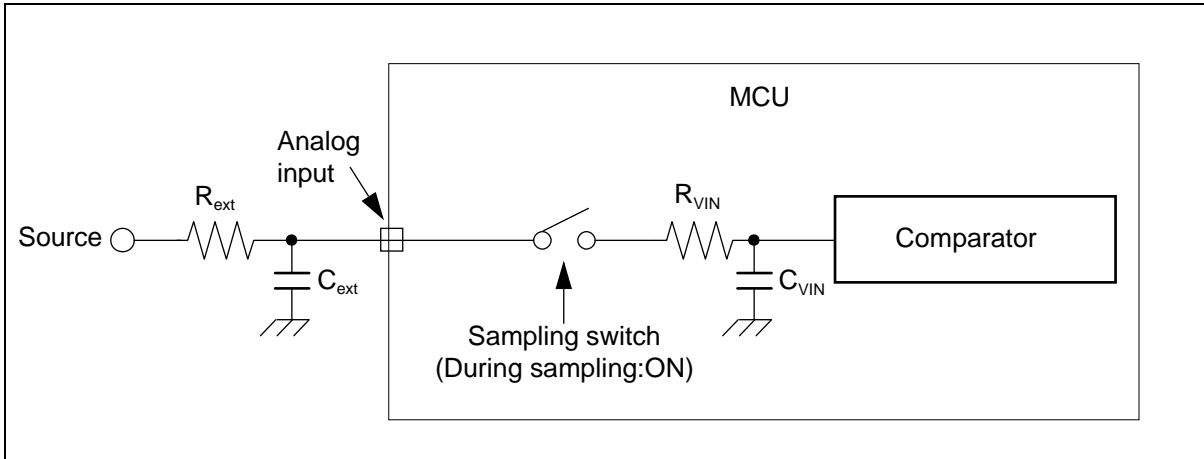

R_{ext} : External driving impedance

C_{ext} : Capacitance of PCB at A/D converter input

C_{VIN} : Analog input capacity (I/O, analog switch and ADC are contained)

R_{VIN} : Analog input impedance (I/O, analog switch and ADC are contained)

The following approximation formula for the replacement model above can be used:

$$T_{\text{samp}} = 7.62 \times (R_{\text{ext}} \times C_{\text{ext}} + (R_{\text{ext}} + R_{\text{VIN}}) \times C_{\text{VIN}})$$

- Do not select a sampling time below the absolute minimum permitted value.
($0.5\mu\text{s}$ for $4.5\text{V} \leq AV_{\text{CC}} \leq 5.5\text{V}$, $1.2\mu\text{s}$ for $2.7\text{V} \leq AV_{\text{CC}} < 4.5\text{V}$)
- If the sampling time cannot be sufficient, connect a capacitor of about $0.1\mu\text{F}$ to the analog input pin.
- A big external driving impedance also adversely affects the A/D conversion precision due to the pin input leakage current I_{IL} (static current before the sampling switch) or the analog input leakage current I_{AIN} (total leakage current of pin input and comparator during sampling). The effect of the pin input leakage current I_{IL} cannot be compensated by an external capacitor.
- The accuracy gets worse as $|AV_{\text{RH}} - AV_{\text{RL}}|$ becomes smaller.

14.5.3 Definition of A/D Converter Terms

- Resolution : Analog variation that is recognized by an A/D converter.
- Nonlinearity error : Deviation of the actual conversion characteristics from a straight line that connects the zero transition point (0b0000000000 ←→ 0b0000000001) to the full-scale transition point (0b1111111110 ←→ 0b1111111111).
- Differential nonlinearity error : Deviation from the ideal value of the input voltage that is required to change the output code by 1LSB.
- Total error : Difference between the actual value and the theoretical value. The total error includes zero transition error, full-scale transition error and nonlinearity error.
- Zero transition voltage: Input voltage which results in the minimum conversion value.
- Full scale transition voltage: Input voltage which results in the maximum conversion value.

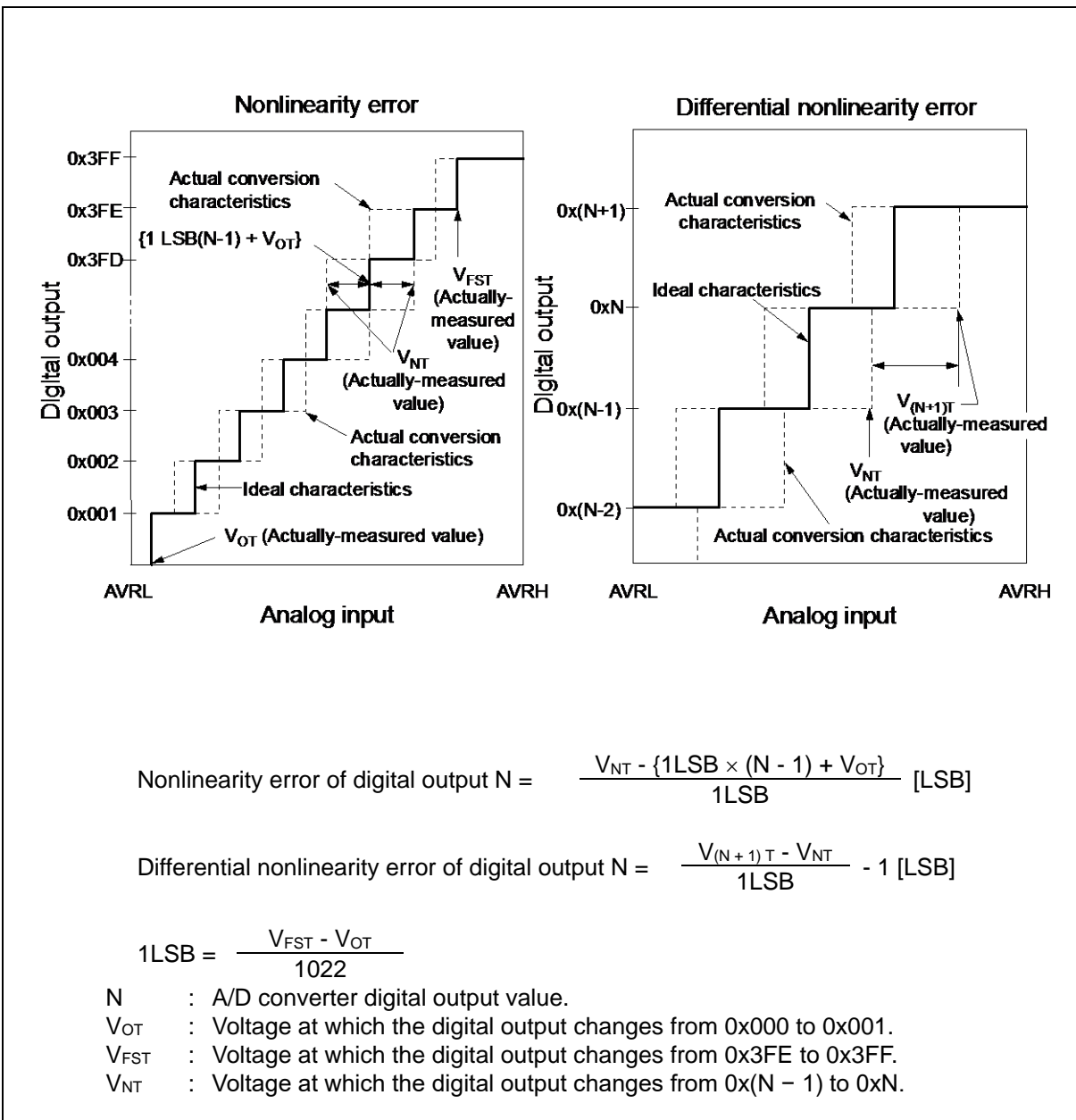

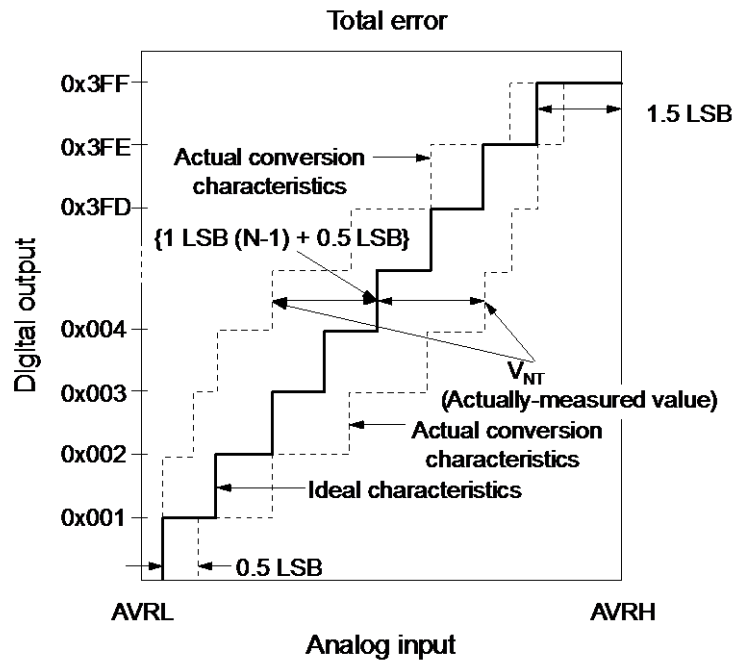

$$1\text{LSB (Ideal value)} = \frac{\text{AVRH} - \text{AVRL}}{1024} \text{ [V]}$$

$$\text{Total error of digital output } N = \frac{V_{NT} - \{1\text{LSB} \times (N - 1) + 0.5\text{LSB}\}}{1\text{LSB}}$$

N : A/D converter digital output value.

V_{NT} : Voltage at which the digital output changes from $0x(N + 1)$ to $0xN$.

V_{OT} (Ideal value) = $\text{AVRL} + 0.5\text{LSB}$ [V]

V_{FST} (Ideal value) = $\text{AVRH} - 1.5\text{LSB}$ [V]

14.6 High Current Output Slew Rate

($V_{CC} = AV_{CC} = DV_{CC} = 2.7V$ to $5.5V$, $V_{SS} = AV_{SS} = DV_{SS} = 0V$, $T_A = -40^{\circ}C$ to $+105^{\circ}C$)

Parameter	Symbol	Pin Name	Conditions	Value			Unit	Remarks
				Min	Typ	Max		
Output rise/fall time	t_{R30} , t_{F30}	P08_m, P09_m, P10_m	Outputs driving strength set to "30mA"	15	-	75	ns	$C_L=85pF$

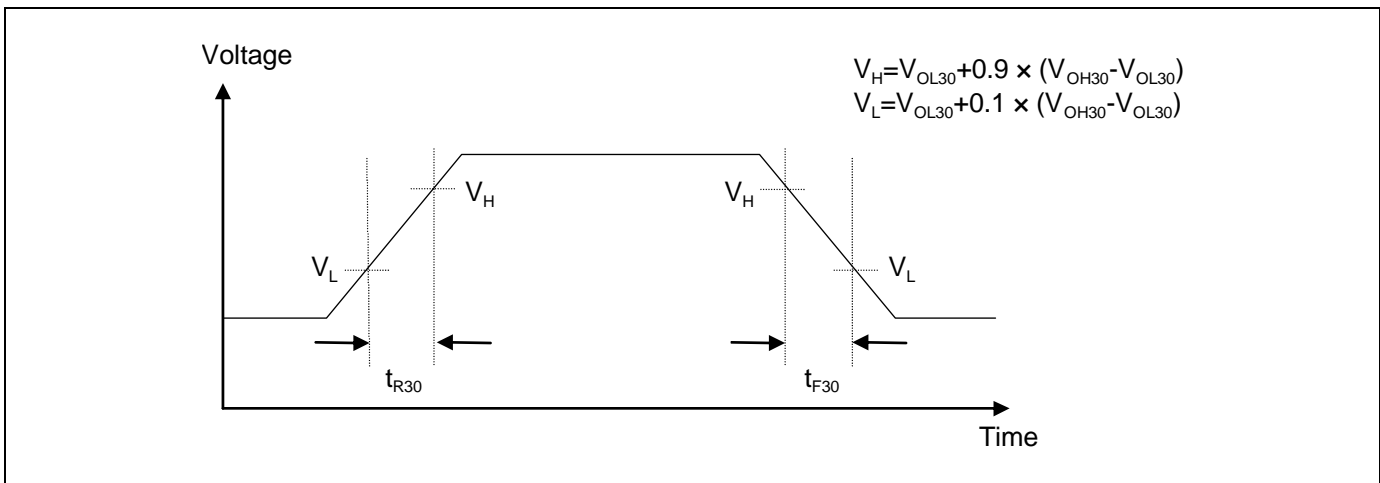

14.7 Low Voltage Detection Function Characteristics

 (V_{CC} = AV_{CC} = DV_{CC} = 2.7V to 5.5V, V_{SS} = AV_{SS} = DV_{SS} = 0V, T_A = - 40°C to + 105°C)

Parameter	Symbol	Conditions	Value			Unit
			Min	Typ	Max	
Detected voltage ^{*1}	V _{DL0}	CILCR:LVL = 0000 _B	2.70	2.90	3.10	V
	V _{DL1}	CILCR:LVL = 0001 _B	2.79	3.00	3.21	V
	V _{DL2}	CILCR:LVL = 0010 _B	2.98	3.20	3.42	V
	V _{DL3}	CILCR:LVL = 0011 _B	3.26	3.50	3.74	V
	V _{DL4}	CILCR:LVL = 0100 _B	3.45	3.70	3.95	V
	V _{DL5}	CILCR:LVL = 0111 _B	3.73	4.00	4.27	V
	V _{DL6}	CILCR:LVL = 1001 _B	3.91	4.20	4.49	V
Power supply voltage change rate ^{*2}	dV/dt	-	- 0.004	-	+ 0.004	V/μs
Hysteresis width	V _{HYS}	CILCR:LVHYS=0	-	-	50	mV
		CILCR:LVHYS=1	80	100	120	mV
Stabilization time	T _{LVDSTAB}	-	-	-	75	μs
Detection delay time	t _d	-	-	-	30	μs

*1: If the power supply voltage fluctuates within the time less than the detection delay time (t_d), there is a possibility that the low voltage detection will occur or stop after the power supply voltage passes the detection range.

*2: In order to perform the low voltage detection at the detection voltage (V_{DLX}), be sure to suppress fluctuation of the power supply voltage within the limits of the change ration of power supply voltage.

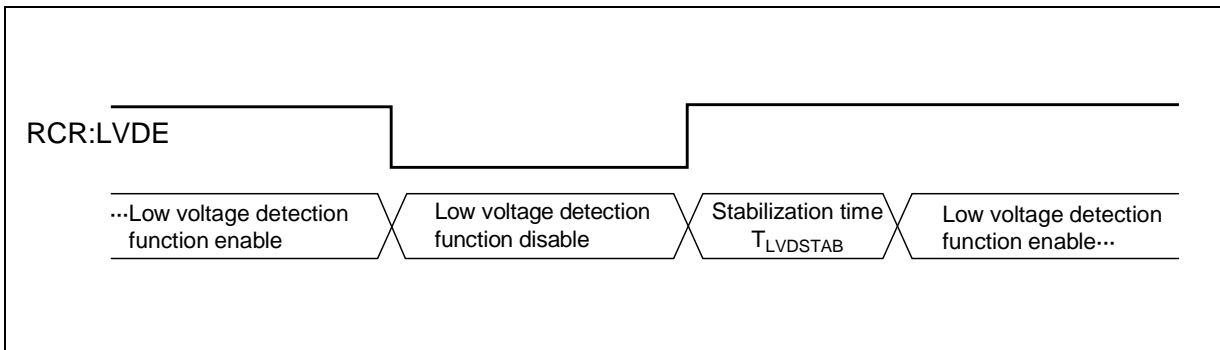
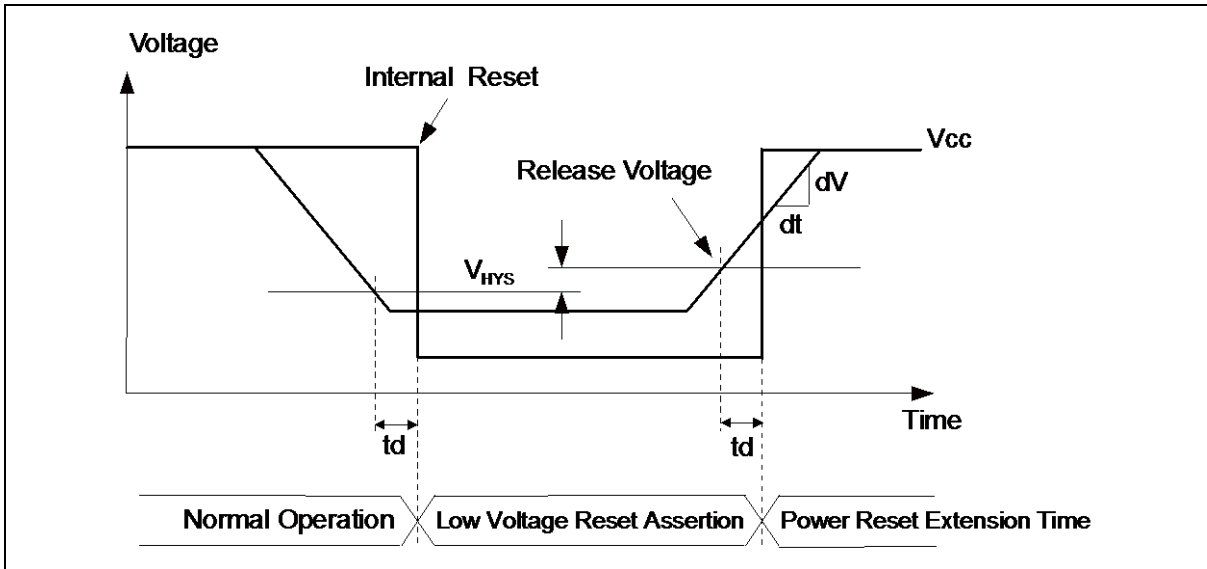
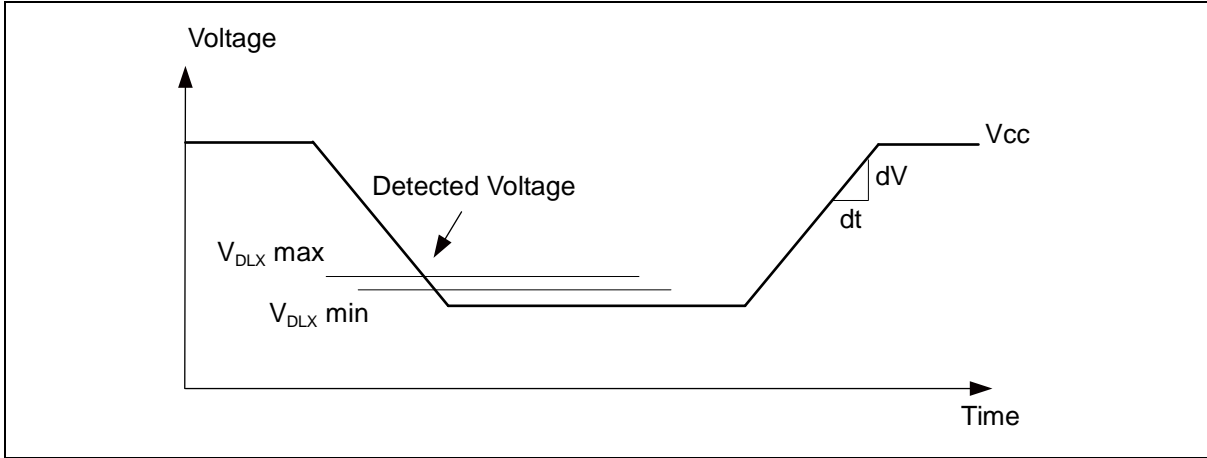

14.8 Flash Memory Write/Erase Characteristics
 $(V_{CC} = AV_{CC} = DV_{CC} = 2.7V \text{ to } 5.5V, V_{SS} = AV_{SS} = DV_{SS} = 0V, T_A = -40^{\circ}C \text{ to } +105^{\circ}C)$

Parameter	Conditions	Value			Unit	Remarks
		Min	Typ	Max		
Sector erase time	Large Sector	-	1.6	7.5	s	Includes write time prior to internal erase.
	Small Sector	-	0.4	2.1	s	
	Security Sector	-	0.31	1.65	s	
Word (16-bit) write time	-	-	25	400	μ s	Not including system-level overhead time.
Chip erase time	-	-	8.31	40.05	s	Includes write time prior to internal erase.

Note: While the Flash memory is written or erased, shutdown of the external power (V_{CC}) is prohibited. In the application system where the external power (V_{CC}) might be shut down while writing or erasing, be sure to turn the power off by using a low voltage detection function.

To put it concrete, change the external power in the range of change ration of power supply voltage ($-0.004V/\mu s$ to $+0.004V/\mu s$) after the external power falls below the detection voltage (V_{DLX})^{*1}.

Write/Erase cycles and data hold time

Write/Erase Cycles (Cycle)	Data Hold Time (Year)
1,000	20^{-2}
10,000	10^{-2}
100,000	5^{-2}

*1: See "14.7. Low Voltage Detection Function Characteristics".

*2: This value comes from the technology qualification (using Arrhenius equation to translate high temperature measurements into normalized value at $+85^{\circ}C$).

15. Example Characteristics

This characteristic is an actual value of the arbitrary sample. It is not the guaranteed value.

■ CY96F6A6

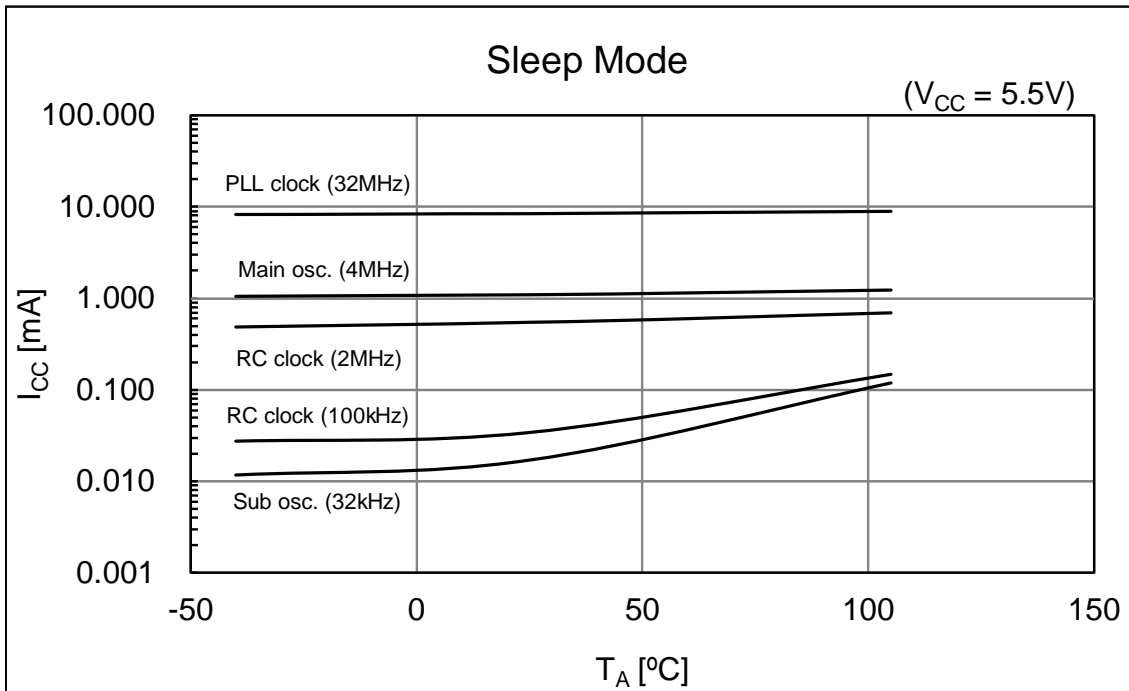
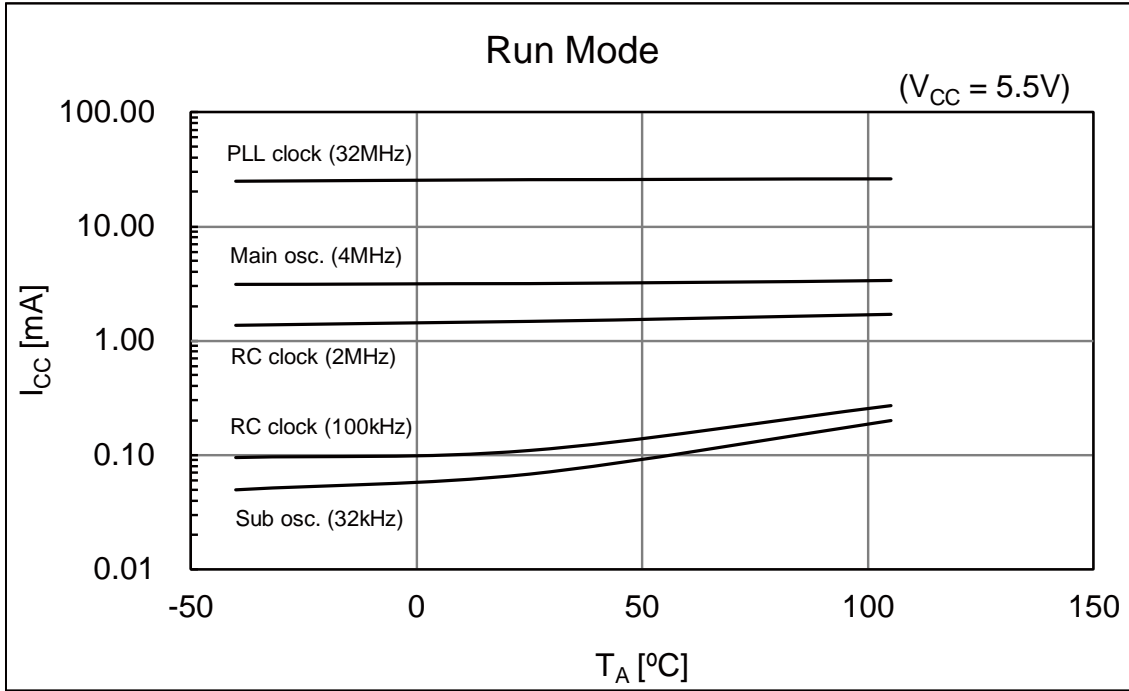

■ CY96F6A6

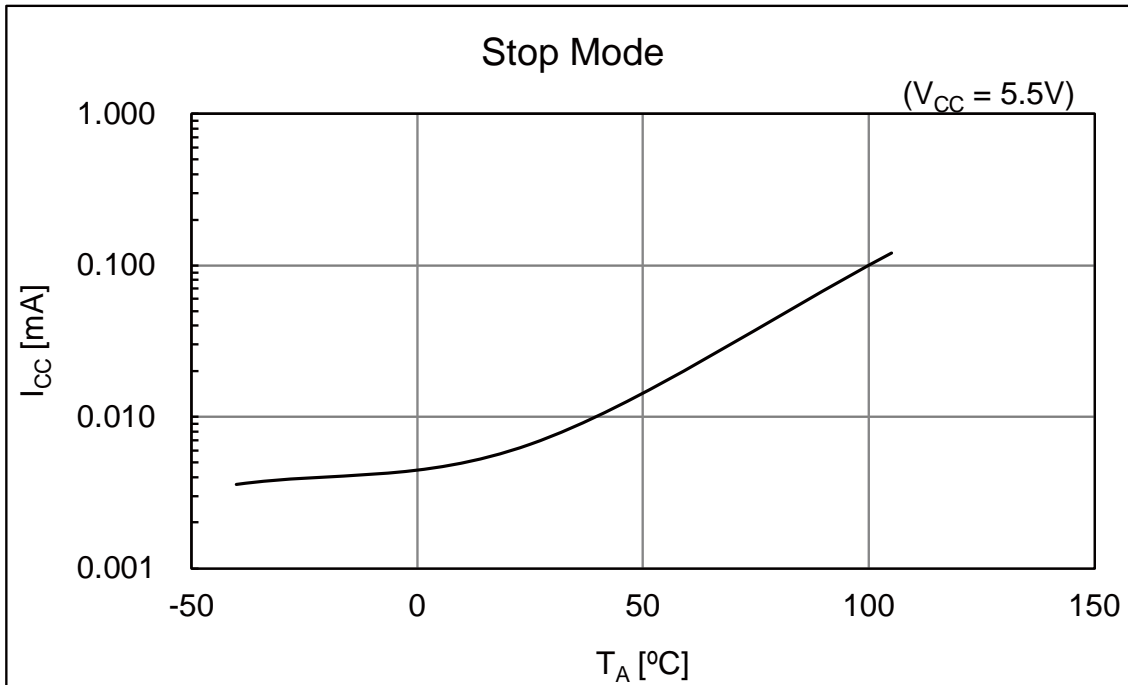
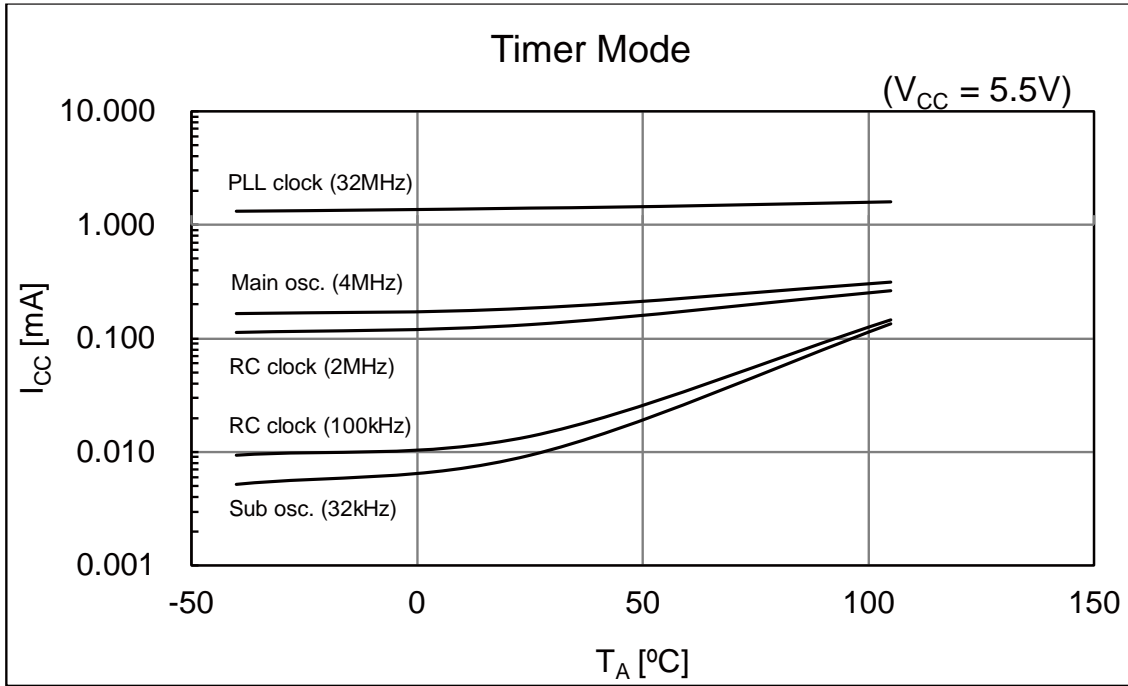

■ Used setting

Mode	Selected Source Clock	Clock/Regulator and FLASH Settings
Run mode	PLL	CLKS1 = CLKS2 = CLKB = CLKP1 = CLKP2 = 32MHz
	Main osc.	CLKS1 = CLKS2 = CLKB = CLKP1 = CLKP2 = 4MHz
	RC clock fast	CLKS1 = CLKS2 = CLKB = CLKP1 = CLKP2 = 2MHz
	RC clock slow	CLKS1 = CLKS2 = CLKB = CLKP1 = CLKP2 = 100kHz
	Sub osc.	CLKS1 = CLKS2 = CLKB = CLKP1 = CLKP2 = 32kHz
Sleep mode	PLL	CLKS1 = CLKS2 = CLKP1 = CLKP2 = 32MHz Regulator in High Power Mode, (CLKB is stopped in this mode)
	Main osc.	CLKS1 = CLKS2 = CLKP1 = CLKP2 = 4MHz Regulator in High Power Mode, (CLKB is stopped in this mode)
	RC clock fast	CLKS1 = CLKS2 = CLKP1 = CLKP2 = 2MHz Regulator in High Power Mode, (CLKB is stopped in this mode)
	RC clock slow	CLKS1 = CLKS2 = CLKP1 = CLKP2 = 100kHz Regulator in Low Power Mode, (CLKB is stopped in this mode)
	Sub osc.	CLKS1 = CLKS2 = CLKP1 = CLKP2 = 32kHz Regulator in Low Power Mode, (CLKB is stopped in this mode)
Timer mode	PLL	CLKMC = 4MHz, CLKPLL = 32MHz (System clocks are stopped in this mode) Regulator in High Power Mode, FLASH in Power-down / reset mode
	Main osc.	CLKMC = 4MHz (System clocks are stopped in this mode) Regulator in High Power Mode, FLASH in Power-down / reset mode
	RC clock fast	CLKMC = 2MHz (System clocks are stopped in this mode) Regulator in High Power Mode, FLASH in Power-down / reset mode
	RC clock slow	CLKMC = 100kHz (System clocks are stopped in this mode) Regulator in Low Power Mode, FLASH in Power-down / reset mode
	Sub osc.	CLKMC = 32 kHz (System clocks are stopped in this mode) Regulator in Low Power Mode, FLASH in Power-down / reset mode
Stop mode	stopped	(All clocks are stopped in this mode) Regulator in Low Power Mode, FLASH in Power-down / reset mode

16. Ordering Information

MCU with CAN Controller

Part Number	Flash Memory	Package*
CY96F6A6RBPMC-GS-UJE1	Flash A (288.5KB)	120-pin plastic LQFP (LQM120)
CY96F6A6RBPMC-GS-UJE2		
CY96F6A6RBPMC-GS-UJERE2		120-pin Reel LQFP (LQM120)

*: For details about package, see "[Package Dimension](#)".

17. Package Dimension

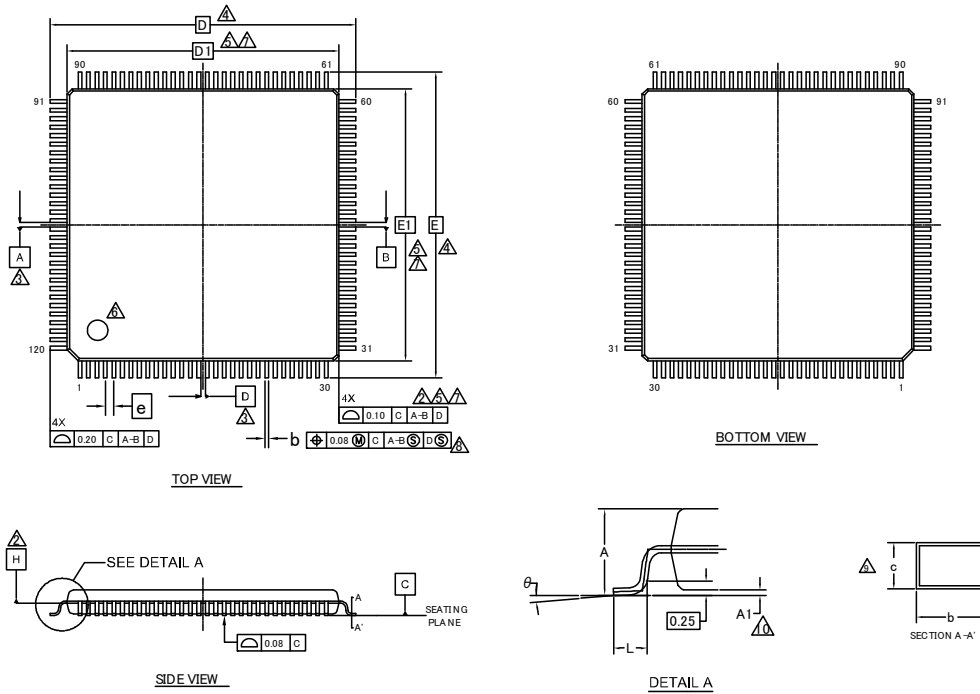

SYMBOL	DIMENSIONS		
	MIN.	NOM.	MAX.
A	—	—	1.70
A1	0.05	—	0.15
b	0.17	0.22	0.27
c	0.115	—	0.195
D	18.00 BSC		
D1	16.00 BSC		
e	0.50 BSC		
E	18.00 BSC		
E1	16.00 BSC		
L	0.45	0.60	0.75
θ	0°	—	8°

NOTES

- ALL DIMENSIONS ARE IN MILLIMETERS.
- DATUM PLANE H IS LOCATED AT THE BOTTOM OF THE MOLD PARTING LINE COINCIDENT WITH WHERE THE LEAD EXITS THE BODY.
- DATUMS A-B AND D TO BE DETERMINED AT DATUM PLANE H.
- TO BE DETERMINED AT SEATING PLANE C.
- DIMENSIONS D1 AND E1 DO NOT INCLUDE MOLD PROTRUSION. ALLOWABLE PROTRUSION IS 0.25mm PRE SIDE. DIMENSIONS D1 AND E1 INCLUDE MOLD MISMATCH AND ARE DETERMINED AT DATUM PLANE H.
- DETAILS OF PIN 1 IDENTIFIER ARE OPTIONAL BUT MUST BE LOCATED WITHIN THE ZONE INDICATED.
- REGARDLESS OF THE RELATIVE SIZE OF THE UPPER AND LOWER BODY SECTIONS, DIMENSIONS D1 AND E1 ARE DETERMINED AT THE LARGEST FEATURE OF THE BODY EXCLUSIVE OF MOLD FLASH AND GATE BURRS, BUT INCLUDING ANY MISMATCH BETWEEN THE UPPER AND LOWER SECTIONS OF THE MOLDER BODY.
- DIMENSION b DOES NOT INCLUDE DAMBAR PROTRUSION. THE DAMBAR PROTRUSION (S) SHALL NOT CAUSE THE LEAD WIDTH TO EXCEED b MAXIMUM BY MORE THAN 0.08mm. DAMBAR CANNOT BE LOCATED ON THE LOWER RADIUS OR THE LEAD FOOT.
- THESE DIMENSIONS APPLY TO THE FLAT SECTION OF THE LEAD BETWEEN 0.10mm AND 0.25mm FROM THE LEAD TIP.
- A1 IS DEFINED AS THE DISTANCE FROM THE SEATING PLANE TO THE LOWEST POINT OF THE PACKAGE BODY.

11. JEDEC SPECIFICATION NO. REF: N/A.

002-16172 **

PACKAGE OUTLINE, 120 LEAD LQFP
18.0X18.0X1.7 MM LQM 120 REV**

18. Major Changes

Spanion Publication Number: MB96F6A6-DS704-00010

Page	Section	Change Results
Revision 1.0		
-	-	PRELIMINARY → Data sheet
2	Features	Changed the description of "System clock" Up to 16 MHz external clock for devices with fast clock input feature → Up to 8 MHz external clock for devices with fast clock input feature
3		Changed the description of "Free-Running Timers" Signals an interrupt on overflow → Signals an interrupt on overflow, supports timer clear upon match with Output Compare (0, 4)
4		Changed the description of "LCD Controller" On-chip drivers for internal divider resistors or external divider resistors → Internal divider resistors or external divider resistors
		Changed the description of "External Interrupts" Interrupt mask and pending bit per channel → Interrupt mask bit per channel
5		Changed the description of "Built-in On Chip Debugger" - Event sequencer: 2 levels → - Event sequencer: 2 levels + reset
6	Product Lineup	Added the Product
		Changed the Remark of RLT RLT 0/1/2/3/6 Only RLT6 can be used as PPG clock source → RLT 0 to 3/6
		Changed number of the I/O Ports 96 (Dual clock mode) 98 (Single clock mode) → 95 (Dual clock mode) 97 (Single clock mode)
7	Block Diagram	Deleted the block of RLT6 from PPG block
		Changed the RLT block 4ch → 0/1/2/3/6 5ch
9	Pin Description	Changed the Description of PPGn_B Programmable Pulse Generator n output (8bit) → Programmable Pulse Generator n output (16bit/8bit)
13	Pin Circuit Type	Changed the I/O circuit type of Pin no.116 P → Q
15	I/O Circuit Type	Changed the figure of type B
		Changed the Remarks of type B (CMOS hysteresis input with input shutdown function, I _{OL} = 4mA, I _{OH} = -4mA, Programmable pull-up resistor) → (CMOS level output (I _{OL} = 4mA, I _{OH} = -4mA), Automotive input with input shutdown function and programmable pull-up resistor)
		Changed the figure of type G
16		Added the Type Q
19		
21	Memory Map	Changed the START addresses of Boot-ROM 0F:E00 _H → 0F:C00 _H

Page	Section	Change Results
23	User ROM Memory Map For Flash Devices	<p>Changed the annotation Others (from DF:0200_H to DF:1FFF_H) are all mirror area of SAS-512B. → Others (from DF:0200_H to DF:1FFF_H) is mirror area of SAS-512B.</p>
25	Interrupt Vector Table	<p>Changed the Description of CALLV0 to CALLV7 Reserved → CALLV instruction</p>
		<p>Changed the Description of RESET Reserved → Reset vector</p>
		<p>Changed the Description of INT9 Reserved → INT9 instruction</p>
		<p>Changed the Description of EXCEPTION Reserved → Undefined instruction execution</p>
26		<p>Changed the Vector name of Vector number 64 PPGRLT → RLT6</p>
		<p>Changed the Description of Vector number 64 Reload Timer 6 can be used as PPG clock source → Reload Timer 6</p>
29 to 32	Handling Precautions	Added a section
34	Handling Devices	<p>Added the description to "3. External clock usage" (3) Opposite phase external clock</p>
		<p>Changed the description in "7. Turn on sequence of power supply to A/D converter and analog inputs" In this case, the voltage must not exceed AVR_H or AV_{CC} → In this case, AVR_H must not exceed AV_{CC}. Input voltage for ports shared with analog input ports also must not exceed AV_{CC}</p>
35	Handling Devices	<p>Changed the description in "11. SMC power supply pins" To avoid this, V_{CC} must always be powered on before DV_{CC}. → To avoid this, V_{CC} must always be powered on before DV_{CC}. DV_{CC}/DV_{SS} must be applied when using SMC I/O pin as GPIO.</p>
		Added the description "13. Mode Pin (MD)"
36	Electrical Characteristics Absolute Maximum Ratings	<p>Changed the Symbol of "L" level average overall output current" $\Sigma I_{OLSMCAV}$ → $\Sigma I_{OLAVSMC}$</p>
		<p>Changed the Symbol of "H" level average overall output current" $\Sigma I_{OHSMCAV}$ → $\Sigma I_{OHAVSMC}$</p>
37		<p>Changed the annotation *2 It is required that AV_{CC} does not exceed V_{CC} and that the voltage at the analog inputs does not exceed AV_{CC} when the power is switched on. → It is required that AV_{CC} does not exceed V_{CC}, DV_{CC} and that the voltage at the analog inputs does not exceed AV_{CC} when the power is switched on.</p>
		<p>Changed the annotation *3 Input/Output voltages of standard ports depend on V_{CC}. → Input/Output voltages of high current ports depend on DV_{CC}. Input/Output voltages of standard ports depend on V_{CC}.</p>

Page	Section	Change Results
		<p>Changed the annotation *4 Note that if the +B input is applied during power-on, the power supply is provided from the pins and the resulting supply voltage may not be sufficient to operate the Power reset (except devices with persistent low voltage reset in internal vector mode). → Note that if the +B input is applied during power-on, the power supply is provided from the pins and the resulting supply voltage may not be sufficient to operate the Power reset.</p> <p>Added the annotation *4 The DEBUG I/F pin has only a protective diode against V_{SS}. Hence it is only permitted to input a negative clamping current (4mA). For protection against positive input voltages, use an external clamping diode which limits the input voltage to maximum 6.0V.</p>
39	Recommended Operating Conditions	<p>Added the Value and Remarks to "Power supply voltage" Min: 2.0V Typ: - Max: 5.5V Remarks: Maintains RAM data in stop mode</p> <p>Changed the Value of "Smoothing capacitor at C pin" Typ: 1.0μF → 1.0μF to 3.9μF Max: 1.5μF → 4.7μF</p> <p>Changed the Remarks of "Smoothing capacitor at C pin" Deleted "(Target value)" Added "3.9μF (Allowance within \pm 20%)"</p>
40	DC Characteristics Current Rating	<p>Deleted "(Target value)"</p> <p>Added the Symbol to "Power supply current in Run modes" I_{CCRCH}, I_{CCRCL}</p> <p>Changed the Conditions of I_{CCPLL}, I_{CCMAIN}, I_{CCSUB} in "Power supply current in Run modes" "Flash 0 wait" is added</p> <p>Changed the Value of "Power supply current in Run modes" I_{CCPLL} Typ: 28.5mA → 28mA ($T_A = +25^\circ\text{C}$) I_{CCMAIN} Typ: 5mA → 3.5mA ($T_A = +25^\circ\text{C}$) Max: 10mA → 8mA ($T_A = +105^\circ\text{C}$) I_{CCSUB} Typ: 0.5mA → 0.1mA ($T_A = +25^\circ\text{C}$) Max: 6mA → 3.3mA ($T_A = +105^\circ\text{C}$)</p>
41		<p>Added the Symbol to "Power supply current in Sleep modes" I_{CCSRCH}, I_{CCSRCL}</p> <p>Changed the Conditions of I_{CCSMAN} in "Power supply current in Sleep modes" "SMCR:LPMSS=0" is added</p> <p>Changed the Value of "Power supply current in Sleep modes" I_{CCSPLL} Typ: 10mA → 9.5mA ($T_A = +25^\circ\text{C}$) I_{CCSMAN} Typ: 3mA → 1.1mA ($T_A = +25^\circ\text{C}$) Max: 8mA → 4.7mA ($T_A = +105^\circ\text{C}$) I_{CCSSUB} Typ: 0.3mA → 0.04mA ($T_A = +25^\circ\text{C}$) Max: 4.5mA → 2.7mA ($T_A = +105^\circ\text{C}$)</p> <p>Added the Symbol to "Power supply current in Timer modes" I_{CCTPLL}</p> <p>Changed the Conditions of $I_{CCTMAIN}$, I_{CCTRCH} in "Power supply current in Timer modes" "SMCR:LPMSS=0" is added</p>

Page	Section	Change Results
41	DC Characteristics Current Rating	<p>Changed the Value of "Power supply current in Timer modes"</p> <p>$I_{CCTMAIN}$ Max: 355μA \rightarrow 330μA ($T_A = +25^\circ$C) Max: 1320μA \rightarrow 1200μA ($T_A = +105^\circ$C)</p> <p>I_{CCTRCH} Max: 245μA \rightarrow 215μA ($T_A = +25^\circ$C) Max: 1230μA \rightarrow 1110μA ($T_A = +105^\circ$C)</p> <p>I_{CCTRCL} Max: 105μA \rightarrow 75μA ($T_A = +25^\circ$C) Max: 1030μA \rightarrow 910μA ($T_A = +105^\circ$C)</p> <p>I_{CCTSUB} Typ: 90μA \rightarrow 65μA ($T_A = +25^\circ$C) Max: 1000μA \rightarrow 885μA ($T_A = +105^\circ$C)</p>
42		<p>Changed the Value of "Power supply current in Stop modes"</p> <p>I_{CCH} Max: 90μA \rightarrow 60μA ($T_A = +25^\circ$C) Max: 1000μA \rightarrow 880μA ($T_A = +105^\circ$C)</p> <p>Added the Symbol</p> <p>$I_{CCFLASHPD}$</p> <p>Changed the Value and condition of "Power supply current for active Low Voltage detector"</p> <p>I_{CCLVD} Typ: 5μA, Max: 15μA, Remarks: nothing \rightarrow Typ: 5μA, Max: -, Remarks: $T_A = +25^\circ$C Typ: -, Max: 12.5μA, Remarks: $T_A = +105^\circ$C</p> <p>Changed the condition of "Flash Write/Erase current"</p> <p>$I_{CCFLASH}$ Typ: 12.5mA, Max: 20mA, Remarks: nothing \rightarrow Typ: 12.5mA, Max: -, Remarks: $T_A = +25^\circ$C Typ: -, Max: 20mA, Remarks: $T_A = +105^\circ$C</p> <p>Changed the annotation *2 The power supply current is measured with a 4MHz external clock connected to the Main oscillator and a 32kHz external clock connected to the Sub oscillator. \rightarrow The power supply current is measured with a 4MHz external clock connected to the Main oscillator and a 32kHz external clock connected to the Sub oscillator. The current for "On Chip Debugger" part is not included.</p>
44	DC Characteristics Pin Characteristics	<p>Added the Symbol for DEBUG I/F pin</p> <p>V_{OLD}</p>

Page	Section	Change Results
45	DC Characteristics Pin Characteristics	Changed the Pin name of "Input capacitance" Other than V _{CC} , V _{SS} , AV _{CC} , AV _{SS} , AVRH, AVRL, P08_m, P09_m, P10_m → Other than C, V _{CC} , V _{SS} , DV _{CC} , DV _{SS} , AV _{CC} , AV _{SS} , AVRH, AVRL, P08_m, P09_m, P10_m
		Deleted the annotation "I _{OH} and I _{OL} are target value."
		Added the annotation "In the case of driving stepping motor directly or high current outputs, set "1" to the bit in the Port High Drive Register (PHDRnn:HDx="1")."
46	AC Characteristics Main Clock Input Characteristics	Changed MAX frequency for f _{FCI} in all conditions 16 → 8 Changed MIN frequency for t _{CYLH} 62.5 → 125 Changed MIN, MAX and Unit for P _{WH} , P _{WL} MIN: 30 → 55 MAX: 70 → - Unit: % → ns
		Added the figure (t _{CYLH}) when using the external clock
47	AC Characteristics Sub Clock Input Characteristics	Added the figure (t _{CYLL}) when using the crystal oscillator clock
48	AC Characteristics Built-in RC Oscillation Characteristics	Added "RC clock stabilization time"
49	AC Characteristics Operating Conditions of PLL	Changed the Value of "PLL input clock frequency" Max: 16MHz → 8MHz
		Changed the Symbol of "PLL oscillation clock frequency" f _{PLLO} → f _{CLKVCO}
		Added Remarks to "PLL oscillation clock frequency"
		Added " PLL phase jitter" and the figure
	AC Characteristics Reset Input	Added the figure for reset input time (t _{RSTL})
51	AC Characteristics USART Timing	Changed the condition (V _{CC} = AV _{CC} = DV _{CC} = 2.7V to 5.5V, V _{SS} = AV _{SS} = DV _{SS} = 0V, T _A = -40°C to + 105°C) → (V _{CC} = AV _{CC} = DV _{CC} = 2.7V to 5.5V, V _{SS} = AV _{SS} = DV _{SS} = 0V, T _A = -40°C to + 105°C, C _L = 50pF)
		Changed the HARDWARE MANUAL "MB966A0 series HARDWARE MANUAL" → "MB96600 series HARDWARE MANUAL"
52		Changed the figure for "Internal shift clock mode"
54	AC Characteristics I ² C timing	Added parameter, "Noise filter" and an annotation *5 for it
		Added t _{SP} to the figure

Page	Section	Change Results
55	A/D Converter Electrical Characteristics for the A/D Converter	Added "Analog impedance"
		Added "Variation between channels"
		Added the annotation
56	A/D Converter Accuracy and Setting of the A/D Converter Sampling Time	Deleted the unit "[Min]" from approximation formula of Sampling time
57	A/D Converter Definition of A/D Converter Terms	Changed the Description and the figure "Linearity" → "Nonlinearity" "Differential linearity error" → "Differential nonlinearity error"
		Changed the Description Linearity error: Deviation of the line between the zero-transition point (0b0000000000 ←→ 0b0000000001) and the full-scale transition point (0b1111111110 ←→ 0b1111111111) from the actual conversion characteristics. → Nonlinearity error: Deviation of the actual conversion characteristics from a straight line that connects the zero transition point (0b0000000000 ←→ 0b0000000001) to the full-scale transition point (0b1111111110 ←→ 0b1111111111).
		Added the Description "Zero transition voltage" "Full scale transition voltage"
		Added the Description "Zero transition voltage" "Full scale transition voltage"
59	High Current Output Slew Rate	Changed the Symbol and figure t_{R2}, t_{F2}, V_{OL2} → $t_{R30}, t_{F30}, V_{OL30}$
60	Low Voltage Detection Function Characteristics	Added the Value of " Power supply voltage change rate" Max: +0.004 V/μs
		Added "Hysteresis width" (V_{HYS})
		Added "Stabilization time" ($T_{LVDSTAB}$)
61	Low Voltage Detection Function Characteristics	Added "Detection delay time" (t_d)
		Deleted the Remarks
		Added the annotation *1, *2
62	Flash Memory Write/Erase Characteristics	Added the figure for "Hysteresis width"
		Added the figure for "Stabilization time"
		Changed the Value of "Sector erase time"
		Added "Security Sector" to "Sector erase time"
		Changed the Parameter "Half word (16 bit) write time" → "Word (16-bit) write time"
		Changed the Value of "Chip erase time"
		Changed the Remarks of "Sector erase time" Excludes write time prior to internal erase → Includes write time prior to internal erase
		Added the Note and annotation *1
Deleted "(targeted value)" from title " Write/Erase cycles and data hold time"		
63 to 65	Example Characteristics	Added a section
66	Ordering information	Changed part number MCU with CAN controller MB96F6A6RAPMC-GSE1* → MB96F6A6RBPMC-GSE1 MB96F6A6RAPMC-GSE2* → MB96F6A6RBPMC-GSE2

Page	Section	Change Results
		Added part number MCU with CAN controller MB96F6A5RBPMC-GSE1 MB96F6A5RBPMC-GSE2 MCU without CAN controller MB96F6A5ABPMC-GSE1 MB96F6A5ABPMC-GSE2
Revision 1.1		
-	-	Company name and layout design change
Rev. *B		
-	Marketing Part Numbers changed from an MB prefix to a CY prefix.	
5, 7, 66, 67	1. Product Lineup 3. Pin Assignment 16. Ordering Information 17. Package Dimension	Package description modified to JEDEC description. FPT-120P-M21 → LQM120
66	16. Ordering Information	Revised Marketing Part Numbers as follows: Before) MCU with CAN controller MB96F6A5RBPMC-GSE1 MB96F6A5RBPMC-GSE2 MB96F6A6RBPMC-GSE1 MB96F6A6RBPMC-GSE2 MCU without CAN controller MB96F6A5ABPMC-GSE1 MB96F6A5ABPMC-GSE2 After) MCU with CAN controller CY96F6A6RBPMC-GS-UJE1 CY96F6A6RBPMC-GS-UJE2 CY96F6A6RBPMC-GS-UJERE2

NOTE: Please see “Document History” about later revised information.

Document History

Document Title: CY96F6A6R, F2MC-16FX CY966A0 Series 16-bit Proprietary Microcontroller
 Document Number: 002-04715

Revision	ECN	Orig. of Change	Submission Date	Description of Change
**	—	TORS	01/31/2014	Migrated to Cypress and assigned document number 002-4715. No change to document contents or format.
*A	5166254	TORS	05/25/2016	Updated to Cypress template.
*B	6003420	MIYH	12/25/2017	Updated Document Title to read as "CY96F6A5R/CY96F6A5A/CY96F6A6R, F ² MC-16FX CY966A0 Series 16-bit Proprietary Microcontroller". Replaced MB966A0 Series with CY966A0 Series in all instances across the document. Changed the prefix of all MPNs from MB to CY in all instances across the document. Replaced FPT-120P-M21 with LQM120 in all instances across the document. Updated Ordering Information. Updated to new template. For details, please see 18. Major Changes.
*C	6601010	TORS	06/21/2019	Updated Document Title to read as "CY96F6A6R, F ² MC-16FX CY966A0 Series 16-bit Proprietary Microcontroller". Updated to new template.

Sales, Solutions, and Legal Information

Worldwide Sales and Design Support

Cypress maintains a worldwide network of offices, solution centers, manufacturer's representatives, and distributors. To find the office closest to you, visit us at [Cypress Locations](#).

Products

Arm® Cortex® Microcontrollers	cypress.com/arm
Automotive	cypress.com/automotive
Clocks & Buffers	cypress.com/clocks
Interface	cypress.com/interface
Internet of Things	cypress.com/iot
Memory	cypress.com/memory
Microcontrollers	cypress.com/mcu
PSoC	cypress.com/psoc
Power Management ICs	cypress.com/pmic
Touch Sensing	cypress.com/touch
USB Controllers	cypress.com/usb
Wireless Connectivity	cypress.com/wireless

PSoC® Solutions

[PSoC 1](#) | [PSoC 3](#) | [PSoC 4](#) | [PSoC 5LP](#) | [PSoC 6 MCU](#)

Cypress Developer Community

[Community](#) | [Projects](#) | [Video](#) | [Blogs](#) | [Training](#) | [Components](#)

Technical Support

cypress.com/support

Arm and Cortex are registered trademarks of Arm Limited (or its subsidiaries) in the US and/or elsewhere.

© Cypress Semiconductor Corporation, 2011-2019. This document is the property of Cypress Semiconductor Corporation and its subsidiaries ("Cypress"). This document, including any software or firmware included or referenced in this document ("Software"), is owned by Cypress under the intellectual property laws and treaties of the United States and other countries worldwide. Cypress reserves all rights under such laws and treaties and does not, except as specifically stated in this paragraph, grant any license under its patents, copyrights, trademarks, or other intellectual property rights. If the Software is not accompanied by a license agreement and you do not otherwise have a written agreement with Cypress governing the use of the Software, then Cypress hereby grants you a personal, non-exclusive, nontransferable license (without the right to sublicense) (1) under its copyright rights in the Software (a) for Software provided in source code form, to modify and reproduce the Software solely for use with Cypress hardware products, only internally within your organization, and (b) to distribute the Software in binary code form externally to end users (either directly or indirectly through resellers and distributors), solely for use on Cypress hardware product units, and (2) under those claims of Cypress's patents that are infringed by the Software (as provided by Cypress, unmodified) to make, use, distribute, and import the Software solely for use with Cypress hardware products. Any other use, reproduction, modification, translation, or compilation of the Software is prohibited.

TO THE EXTENT PERMITTED BY APPLICABLE LAW, CYPRESS MAKES NO WARRANTY OF ANY KIND, EXPRESS OR IMPLIED, WITH REGARD TO THIS DOCUMENT OR ANY SOFTWARE OR ACCOMPANYING HARDWARE, INCLUDING, BUT NOT LIMITED TO, THE IMPLIED WARRANTIES OF MERCHANTABILITY AND FITNESS FOR A PARTICULAR PURPOSE. No computing device can be absolutely secure. Therefore, despite security measures implemented in Cypress hardware or software products, Cypress shall have no liability arising out of any security breach, such as unauthorized access to or use of a Cypress product. CYPRESS DOES NOT REPRESENT, WARRANT, OR GUARANTEE THAT CYPRESS PRODUCTS, OR SYSTEMS CREATED USING CYPRESS PRODUCTS, WILL BE FREE FROM CORRUPTION, ATTACK, VIRUSES, INTERFERENCE, HACKING, DATA LOSS OR THEFT, OR OTHER SECURITY INTRUSION (collectively, "Security Breach"). Cypress disclaims any liability relating to any Security Breach, and you shall and hereby do release Cypress from any claim, damage, or other liability arising from any Security Breach. In addition, the products described in these materials may contain design defects or errors known as errata which may cause the product to deviate from published specifications. To the extent permitted by applicable law, Cypress reserves the right to make changes to this document without further notice. Cypress does not assume any liability arising out of the application or use of any product or circuit described in this document. Any information provided in this document, including any sample design information or programming code, is provided only for reference purposes. It is the responsibility of the user of this document to properly design, program, and test the functionality and safety of any application made of this information and any resulting product. "High-Risk Device" means any device or system whose failure could cause personal injury, death, or property damage. Examples of High-Risk Devices are weapons, nuclear installations, surgical implants, and other medical devices. "Critical Component" means any component of a High-Risk Device whose failure to perform can be reasonably expected to cause, directly or indirectly, the failure of the High-Risk Device, or to affect its safety or effectiveness. Cypress is not liable, in whole or in part, and you shall and hereby do release Cypress from any claim, damage, or other liability arising from any use of a Cypress product as a Critical Component in a High-Risk Device. You shall indemnify and hold Cypress, its directors, officers, employees, agents, affiliates, distributors, and assigns harmless from and against all claims, costs, damages, and expenses, arising out of any claim, including claims for product liability, personal injury or death, or property damage arising from any use of a Cypress product as a Critical Component in a High-Risk Device. Cypress products are not intended or authorized for use as a Critical Component in any High-Risk Device except to the limited extent that (i) Cypress's published data sheet for the product explicitly states Cypress has qualified the product for use in a specific High-Risk Device, or (ii) Cypress has given you advance written authorization to use the product as a Critical Component in the specific High-Risk Device and you have signed a separate indemnification agreement.

Cypress, the Cypress logo, Spansion, the Spansion logo, and combinations thereof, WICED, PSoC, CapSense, EZ-USB, F-RAM, and Traveo are trademarks or registered trademarks of Cypress in the United States and other countries. For a more complete list of Cypress trademarks, visit cypress.com. Other names and brands may be claimed as property of their respective owners.