

Features

- Low gate charge
- Low Crss (typical 25pF)
- Fast switching
- 100% avalanche tested
- Improved dv/dt capability
- RoHS product

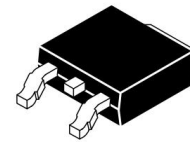

TO-252

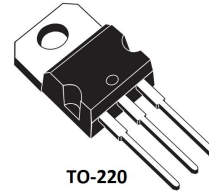

TO-220

Applications

- High efficiency switch mode power supplies
- Electronic lamp ballasts based on half bridge
- UPS

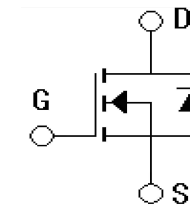

Absolute Ratings (Tc=25°C)

Parameter	Symbol	Value	Unit
Drain-Source Voltage	V _{DSS}	200	V
Drain Current -continuous	I _D , T=25°C T=100°C	18	A
		16	A
Drain Current - pulse (note 1)	I _{DM}	72	A
Gate-Source Voltage	V _{GSS}	±30	V
Single Pulsed Avalanche Energy (note 2)	E _{AS}	259	mJ
Avalanche Current (note 1)	I _{AR}	18	A
Repetitive Avalanche Current (note 1)	E _{AR}	14	mJ
Peak Diode Recovery dv/dt (note 3)	dv/dt	5.5	V/ns
Power Dissipation	PD TC=25°C Derate above 25°C	140	W
		1.12	W/°C
Operating and Storage Temperature Range	T _J , T _{STG}	-55~+150	°C
Maximum Lead Temperature for Soldering Purposes	T _L	300	°C

*Drain current limited by maximum junction temperature

Electrical Characteristics($T_{CASE}=25^{\circ}C$ unless otherwise specified)

Parameter	Symbol	Tests conditions	Min	Type	Max	Units
Off-Characteristics						
Drain-Source Voltage	BV_{DSS}	$I_D=250\mu A, V_{GS}=0V$	200	-	-	V
Breakdown Voltage Temperature Coefficient	$\Delta BV_{DSS} / \Delta T_J$	$I_D=250\mu A$, referenced to $25^{\circ}C$	-	0.2	-	V/ $^{\circ}C$
Drain cut-off current	I_{DSS}	$V_{DS}=200V, V_{GS}=0V$ $T_J=25^{\circ}C$	-	-	1	μA
		$V_{DS}=160V, T_J=125^{\circ}C$	-	-	10	
Gate-body leakage current, forward	I_{GSSF}	$V_{DS}=0V, V_{GS}=30V$	-	-	100	nA
Gate-body leakage current, reverse	I_{GSSR}	$V_{DS}=0V, V_{GS}=-30V$	-	-	-100	nA
On-Characteristics						
Gate Threshold Voltage	$V_{GS(th)}$	$V_{DS}=V_{GS}, I_D=250\mu A$	2.0	-	4.0	V
Static Drain-Source On-Resistance	$R_{DS(ON)}$	$V_{GS}=10V, I_D=9A$ $25^{\circ}C$	0.08	0.12	0.15	Ω
Forward Transconductance	g_{fs}	$V_{DS}=40V, I_D=9A$ (note 4)	-	14.5	-	S
Dynamic Characteristics						
Gate resistance	R_g	F=1.0MHZ open drain	0.5	1.5	2.5	Ω
Input capacitance	C_{iss}	$V_{DS}=25V,$ $V_{GS}=0V,$ $f=1.0MHZ$	350	1001	1650	pF
Output capacitance	C_{oss}		104	173	300	pF
Reverse transfer capacitance	C_{rss}		15	25	40	pF

Switching Characteristics						
Turn-On delay time	$t_d(on)$	$V_{DD}=100V, I_D=18A,$ $R_G=25\Omega,$ $V_{GS}=10V$ (note 4,5)	9	15.2	21	ns
Turn-On rise time	t_r		16.5	38.7	60	ns
Turn-Off delay time	$t_d(off)$		21.5	46.4	71.5	ns
Turn-Off Fall time	t_f		6.8	12.8	18.8	ns
Total Gate Charge	Q_g	$V_{DS}=160V,$ $I_D=18A,$ $V_{GS}=10V$ (note4,5)	12	27.5	42	nC
Gate-Source charge	Q_{gs}		2.5	5.7	8.9	nC
Gate-Drain charge	Q_{gd}		5.8	10.8	15.8	nC
Drain-Source Diode Characteristics and Maximum Ratings						
Drain-Source Diode Forward Voltage	V_{SD}	$V_{GS}=0V, I_S=18A$	-	-	1.4	V

Maximum Continuous Drain-Source Diode Forward Current	I_S		-	-	18	A
Maximum Pulsed Drain-Source Diode Forward Current	I_{SM}		-	-	72	A
Reverse recovery time	trr	VGS=0V, IS=18A dIF/dt=100A/us(note 4)	124	224	324	ns
Reverse recovery charge	Qrr		0.58	1.38	2.18	uC

Thermal Characteristic

Parameter	Symbol	Value	Unit
Thermal Resistance, Junction-to-Case	$R_{\theta JC}$	0.89	$^{\circ}C/W$
Thermal Resistance, Junction-to-Ambient	$R_{\theta JA}$	62.5	$^{\circ}C/W$

Type	Package
MS18N20FD	TO-252
MS18N20FT	TO-220

Notes:

- 1: Pulse width limited by maximum junction temperature
- 2: $L=1.6mH, I_{AS}=18A, V_{DD}=50V, R_G=25\Omega$, Starting $T_J=25^{\circ}C$
- 3: $I_{SD}\leq 18A, di/dt\leq 200A/us, V_{DD}\leq BV_{DSS}$, Starting $T_J=25^{\circ}C$
- 4: Pulse Test: Pulse Width $\leq 300us$, Duty Cycle $\leq 2\%$
- 5: Essentially independent of operating temperature

Electrical Characteristics

Typical Output Characteristics, $T_C=25^{\circ}C$

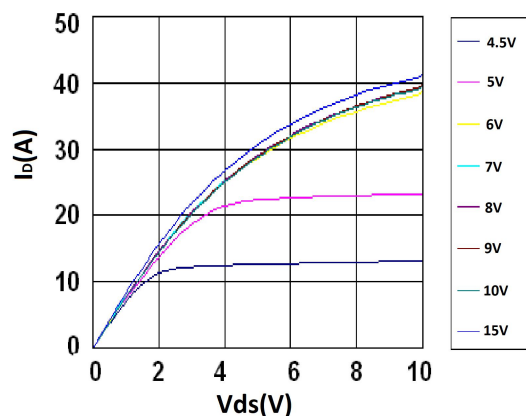

Transfer Characteristics

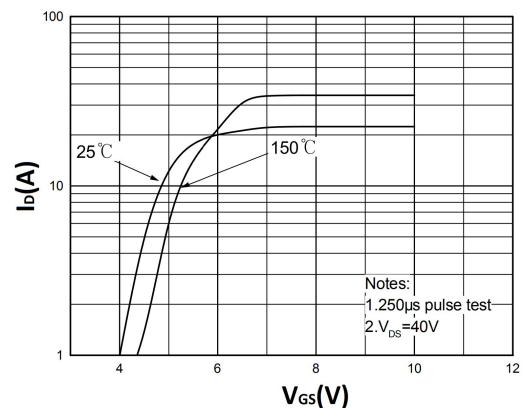

Breakdown Voltage Variation vs. Temperature

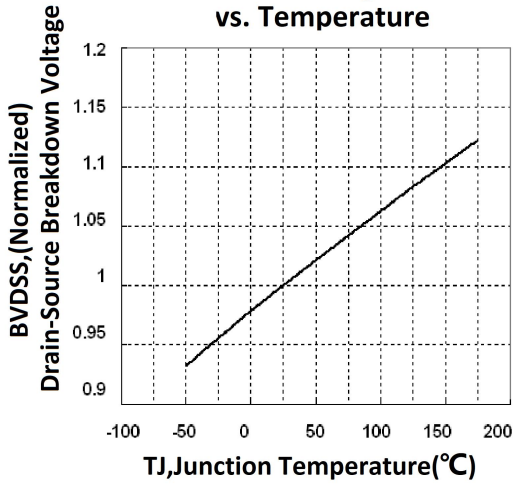

Body Diode Forward Voltage Variation vs. Source Current and Temperature

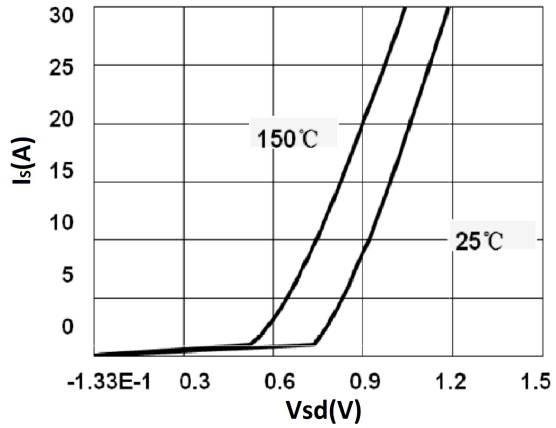

Capacitance Characteristics

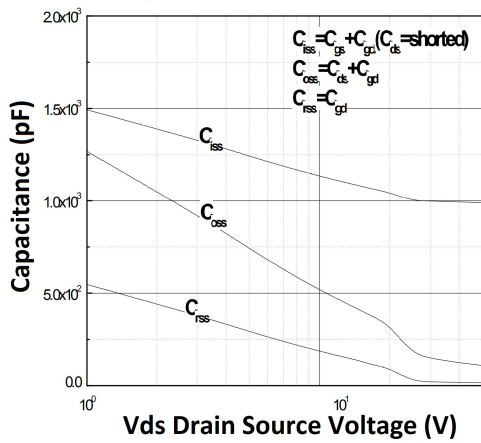

Gate Charge Characteristics

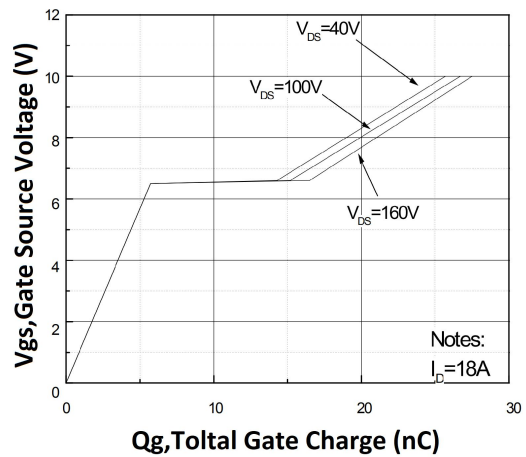

On-Resistance Variation vs. Temperature

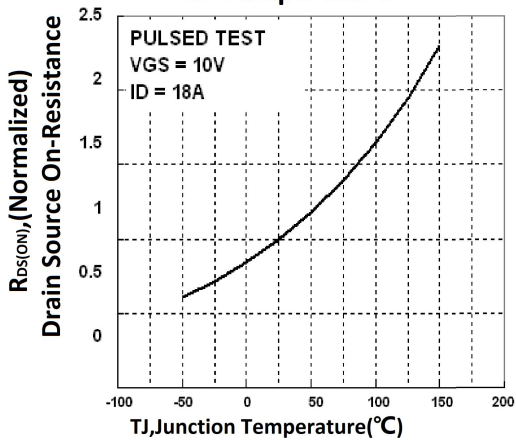

Maximum Drain Current vs. Case Temperature

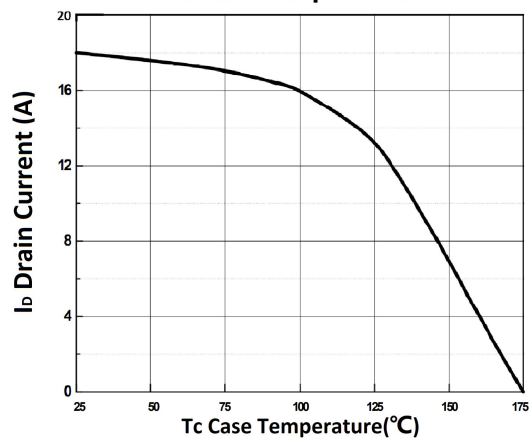

Maximum Safe Operating Area

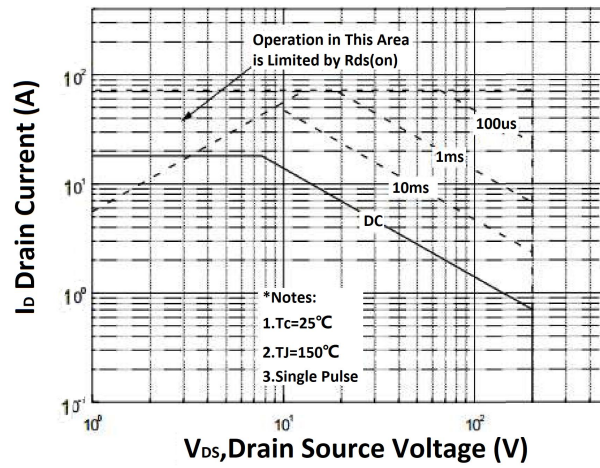

Transient Thermal Response Curve

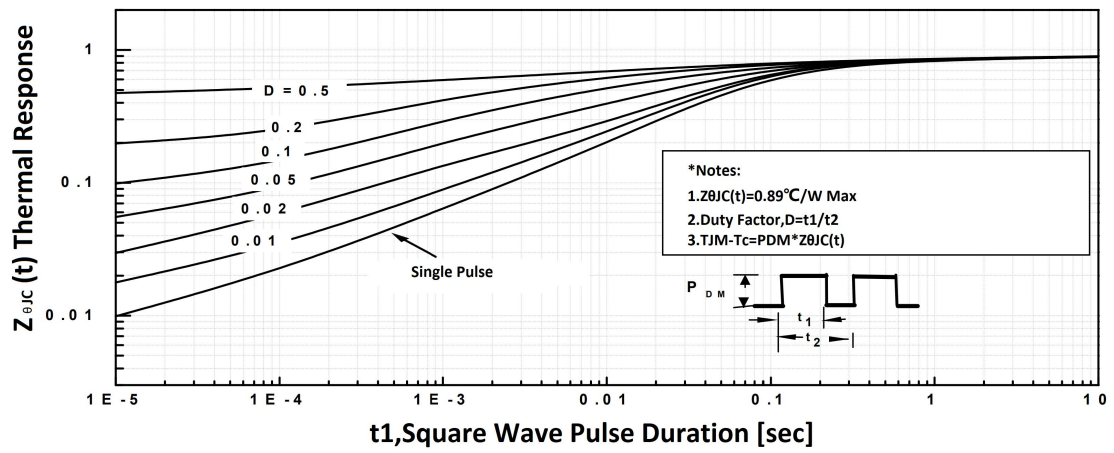

Package Mechanical DATA

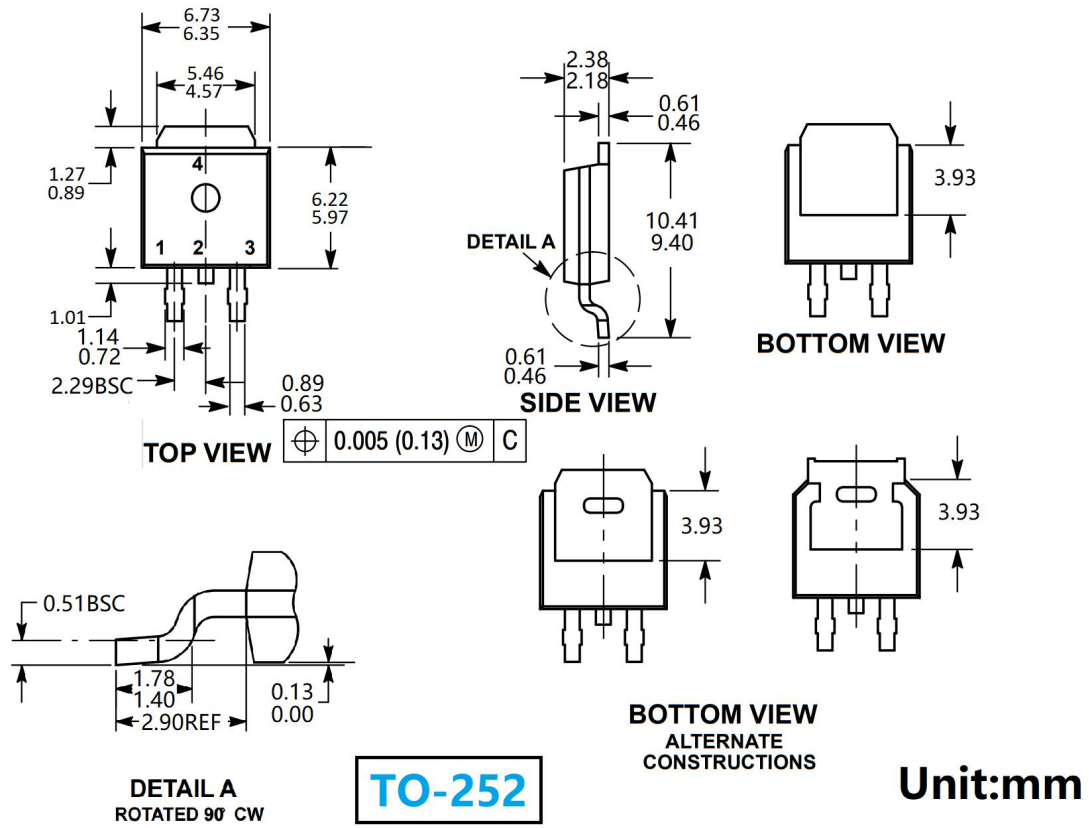

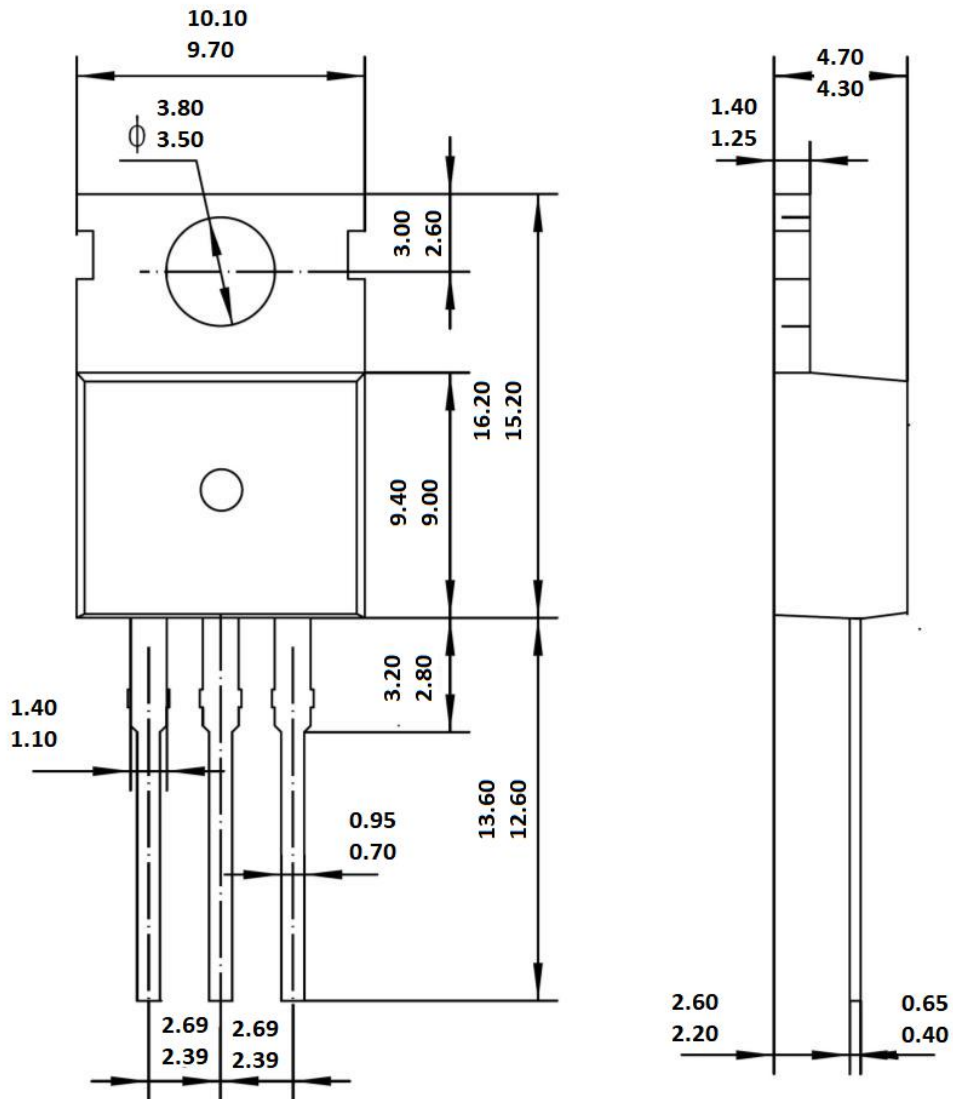

TO-220

Unit: mm