

申明: 凡是没有产品料号或有“PRELIMINARY”标示的产品图均为临时图面暂不能生产/DECLARATION: ALL PRODUCT DRAWINGS WITHOUT THE PART NUMBER OR WITH “PRELIMINARY” LABEL ARE TEMPORARY DRAWINGS CAN NOT BE PRODUCED

REV.	ECN NO.	DESCRIPTION	DATE	DESIGN
B	ECN NO.	UPDATE THE DRAWING		
C	ECN NO.	UPDATE THE DRAWING		

NOTE:

1.MATERIAL SPECIFICATION:

- 1.HOUSING:LCP,UL94 V-0.
- 2.TERMINAL: COPPER ALLOY(C1814)
- 3.MID PLATE: STAINLESS STEEL(SUS301)
- 4.FRONT SHELL: STAINLESS STEEL(SUS304)

2.PLATING SPECIFICATION:

- 2-1.TERMINAL:  
Ni 50u" MIN. UNDER PLATED OVER ALL.  
Au PLATED ON THE FUNCTIONAL AREA OF CONTACT.  
(GOLD PLATING THICKNESS FOLLOW THE P/N)  
PLATING SPECIFICATIONS OF THE SOLDER AREA FOLLOW THE P/N

2-2.FRONT SHELL:

- Ni 50u" MIN. UNDER PLATED OVER ALL.

2-3.MID PLATE:

- CLEAR ONLY

3.MECHANICAL PERFORMANCE,

- 3-1.INSERTION FORCE: 0.5~2.0kgf.
- 3-2.REMOVAL FORCE: 0.8kgf~2.0kgf.
- 3-3.DURABILITY: 10000 CYCLES.

4.ELECTRICAL PERFORMANCE,

- 4-1. VOLTAGE RATING:5 V DC/AC (RMS. max)  
CURRENT RATING:5 AMPS. FOR TOTAL VBUS/GND PINS;  
1.25AMPS FOR CC PIN,0.25 AMPS. FOR ALL OTHER CONTACT.

4-2. LLCR:

- VBUS & GND PINS AND OTHER PINS: 40mΩ/PIN MAX.  
SHIELD: 50mΩ/MAX.  
LLCR MAX. CHANGE OF ALL PINS: 10mΩ.

4-3.INSULATION RESISTANCE: 100MΩ MIN

4-4.DIELECTRIC WITHSTAND VOLTAGE,AC 100V FOR 1 MINUTE.

5. ENVIRONMENTAL PERFORMANCE:

- OPERATING TEMPERATURE: -25°C~+85°C.

6.IR REFLOW:

- THE PEAK TEMPERATURE ON THE BOARD SHALL BE MAINTAINED FOR 10 SECONDS AT 260°C.

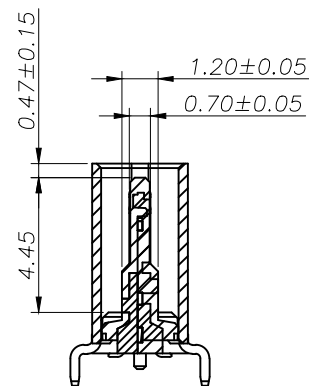
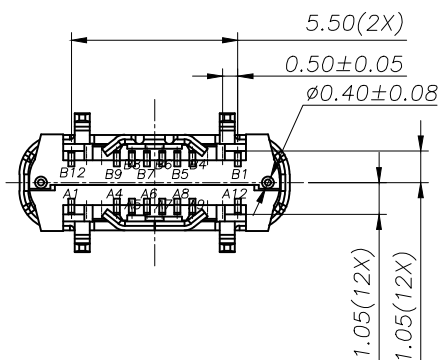
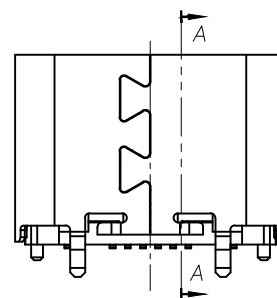
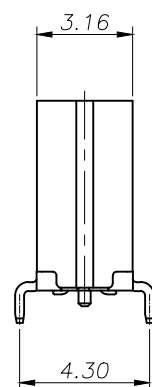
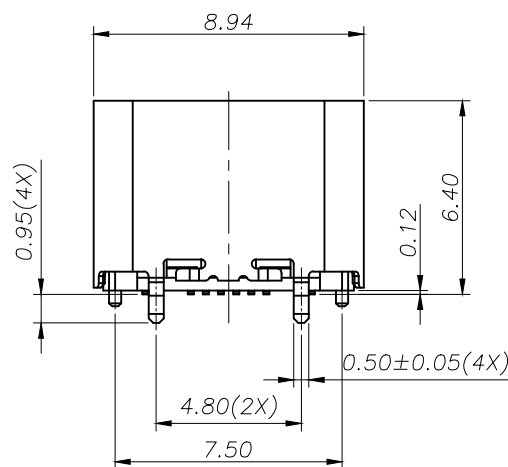
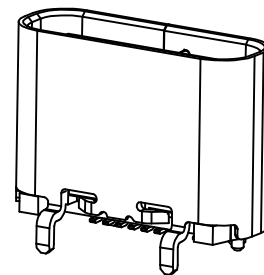
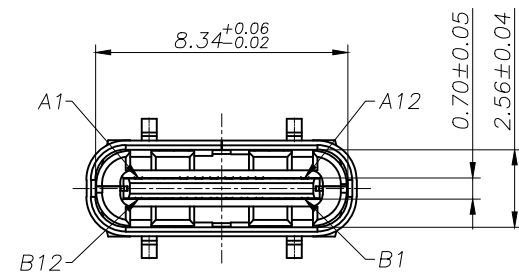

SECTION:A-A

TOLERANCE		NAME(INTENDED USE) CUSTOMER DRAWING	兆星精密电子(深圳)有限公司		
X.X ±0.30	X.* ±10°	PART NO.	TITLE: Type-C 母座 立贴		
.XX ±0.20	.X* ± 8°	ZX-TYPEC-LTM1628	DRAWG NO. ZX-TYPEC-LTM1628		
.XXX ±0.10	.XX* ± 5°	DESIGN:	SCALE SHEET REV.		
UNITS	mm	CHED:	1:1	1/3	C
MATERILA		APPD:			
FINISH					



申明: 凡是没有产品料号或有“PRELIMINARY”标示的产品图均为临时图面暂不能生产/DECLARATION: ALL PRODUCT DRAWINGS WITHOUT THE PART NUMBER OR WITH “PRELIMINARY” LABEL ARE TEMPORARY DRAWINGS CAN NOT BE PRODUCED

REV.	ECN NO.	DESCRIPTION	DATE	DESIGN
B	ECN NO.	UPDATE THE DRAWING		
C	ECN NO.	UPDATE THE DRAWING		

USB TYPE-C PIN ASSIGNMENTS

PIN NUMBER	SIGNAL NAME	PIN NUMBER	SIGNAL NAME
A1	GND	B12	GND
A4	VBUS	B9	VBus
A5	CC1	B8	SBU2
A6	Dp1	B7	Dn2
A7	Dn1	B6	Dp2
A8	SBU1	B5	CC2
A9	VBUS	B4	VBus
A12	GND	B1	GND

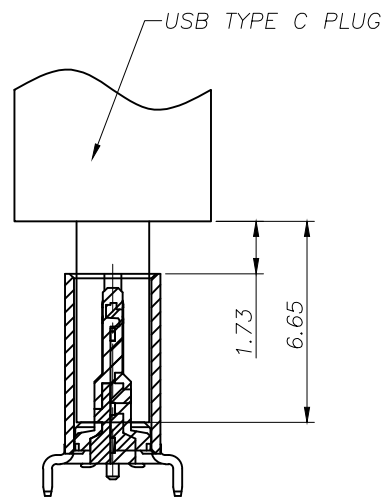

FEMALE AND MALE MATCHING DRAWING

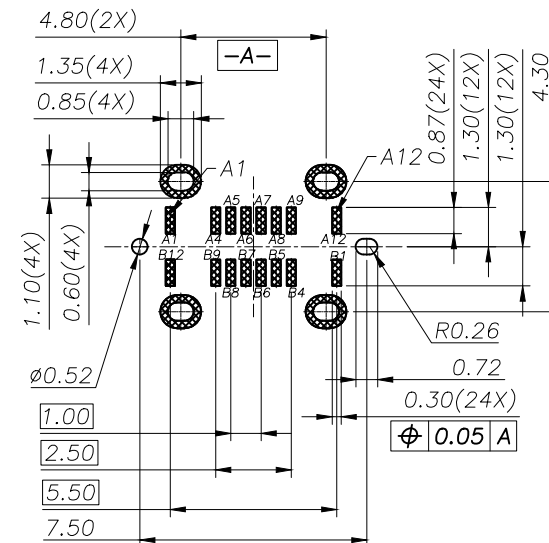

RECOMMENDED PCB LAYOUT(TOP VIEW)  
THICKNESS 0.8±0.10MM;DEFAULT TOLERANCE:±0.05

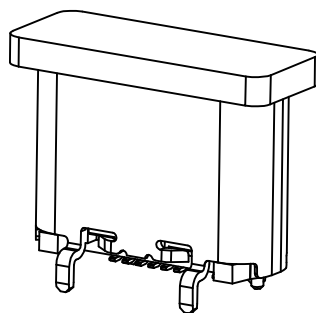
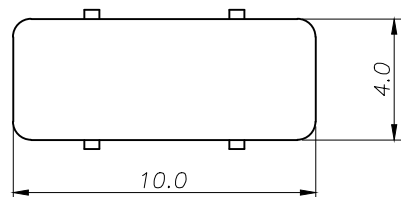

WITH COVER SCHEMATIC

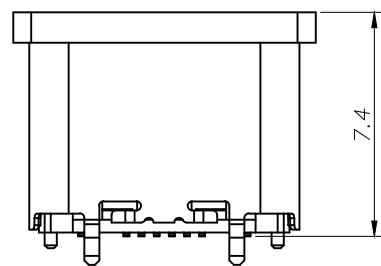

TOLERANCE		NAME(INTENDED USE) CUSTOMER DRAWING	兆星精密电子(深圳)有限公司		
X.X ±0.30	X.* ±10°	PART NO.	TITLE:		
.XX ±0.20	.X* ± 8°	ZX-TYPEC-LTM1628	Type-C 母座 立贴		
.XXX ±0.10	.XX* ± 5°	DESIGN:	DRAWG NO. ZX-TYPEC-LTM1628		
UNITS	mm	CHED:	SCALE SHEET REV.		
MATERILA		APPD:	1:1	2/3	C
FINISH					

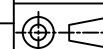

申明：凡是没有产品料号或有“PRELIMINARY”标示的产品图均为临时图面暂不能生产 / DECLARATION: ALL PRODUCT DRAWINGS WITHOUT THE PART NUMBER OR WITH "PRELIMINARY" LABEL ARE TEMPORARY DRAWINGS CAN NOT BE PRODUCED

REV.	ECN NO.	DESCRIPTION	DATE	DESIGN
B	ECN NO.	UPDATE THE DRAWING		
C	ECN NO.	UPDATE THE DRAWING		

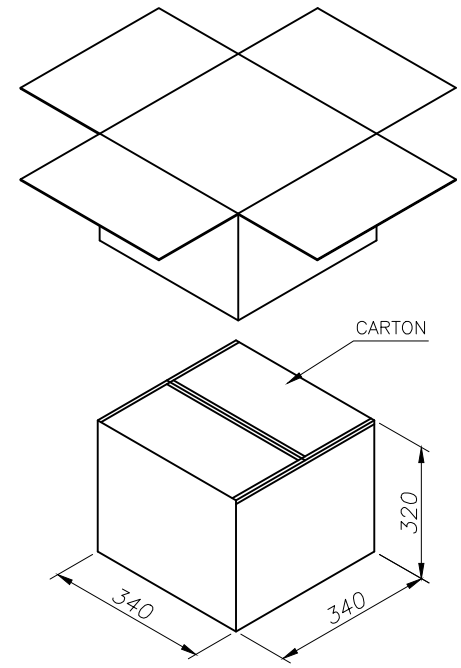
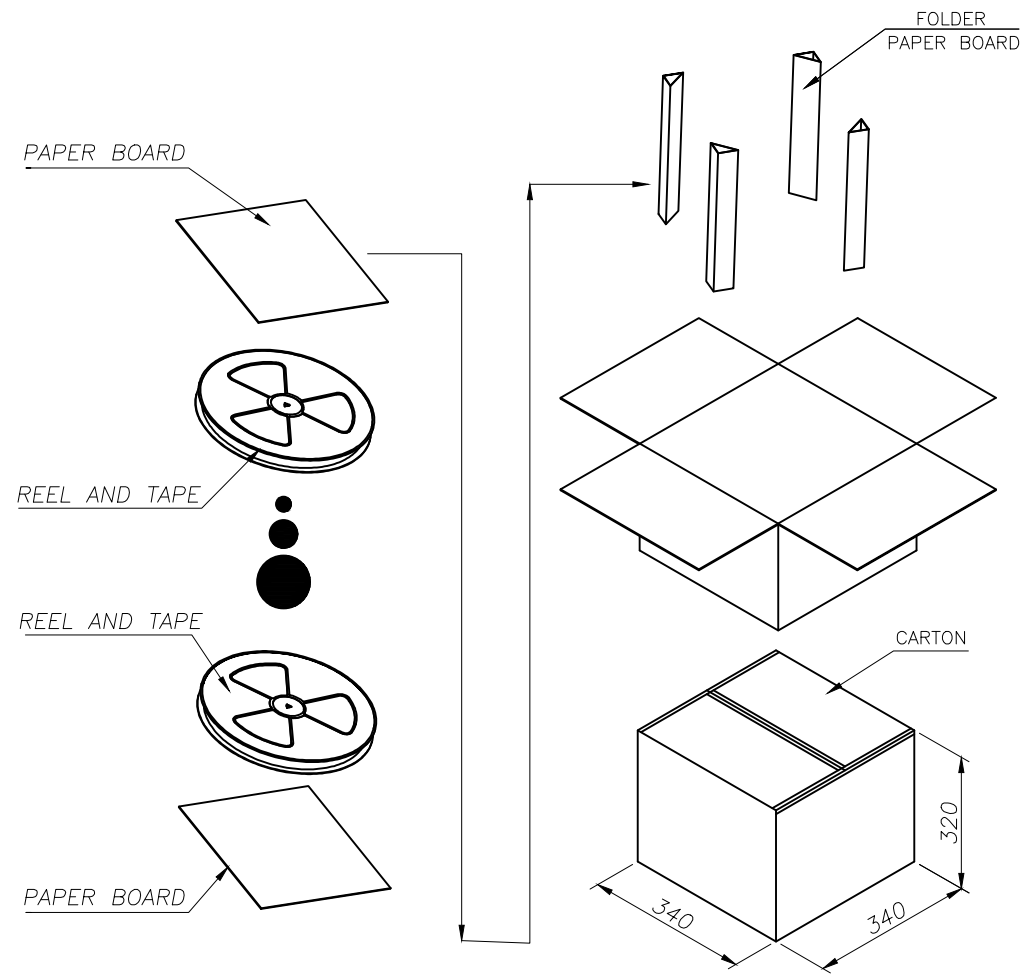
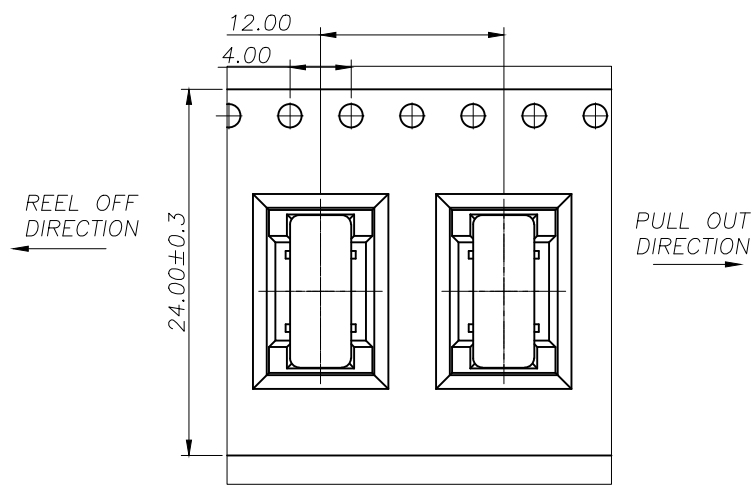
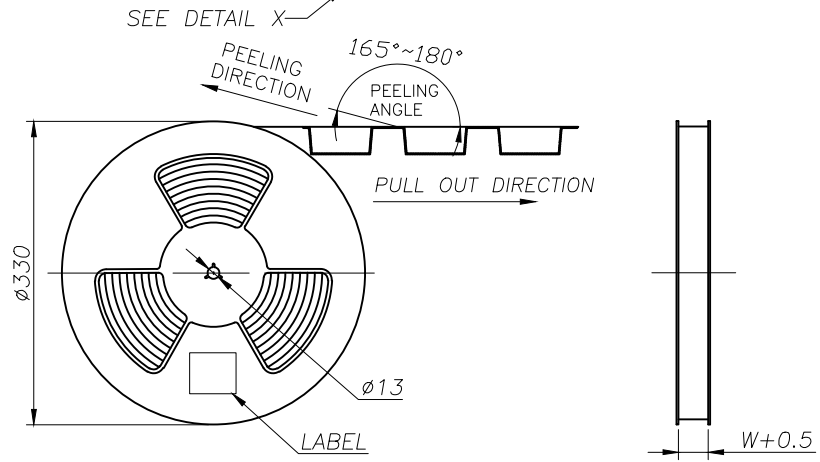
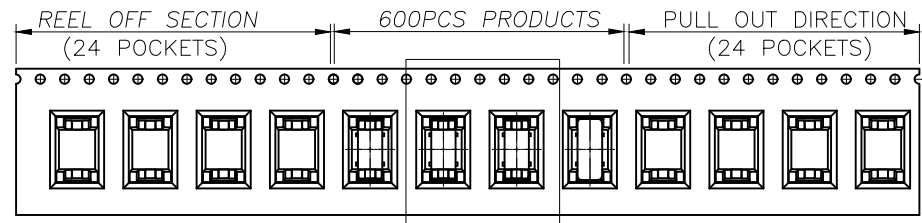

	REEL/TRAY	CARTON
CONNECTOR (PCS)	600	6000

TOLERANCE		NAME(INTENDED USE) CUSTOMER DRAWING	兆星精密电子(深圳)有限公司 TITLE: Type-C 母座 立贴						
X.X ±0.30	X.* ±10°	PART NO. ZX-TYPEC-LTM1628							
.XX ±0.20	.X* ± 8°	DESIGN:	DRAWG NO. ZX-TYPEC-LTM1628						
.XXX ±0.10	.XX* ± 5°	CHEG:	<table border="1"> <tr> <th>SCALE</th> <th>SHEET</th> <th>REV.</th> </tr> <tr> <td>1:1</td> <td>3/3</td> <td>C</td> </tr> </table>	SCALE	SHEET	REV.	1:1	3/3	C
SCALE	SHEET	REV.							
1:1	3/3	C							
UNITS	mm	APPD:							
MATERILA									
FINISH									