



AiP74LVC74

Dual D-type flip-flop with set and reset; positive-edge trigger

Product Specification

Specification Revision History:

Version	Date	Description
2017-05-A1	2017-05	New
2021-08-A2	2021-08	Modify Supply Current Parameter
2021-12-A3	2021-12	Modify Ordering Information
2022-02-A4	2022-02	Modify ambient temperature to -40°C~+105°C and add electrical characteristics of -40°C~+105°C



1、 General Description

The AiP74LVC74 is a dual edge triggered D-type flip-flop with individual data (nD) inputs, clock (nCP) inputs, set (\overline{nSD}) and (\overline{nRD}) inputs, and complementary nQ and \overline{nQ} outputs.

The set and reset are asynchronous active LOW inputs and operate independently of the clock input. Information on the data input is transferred to the nQ output on the LOW-to-HIGH transition of the clock pulse. The nD inputs must be stable one set-up time prior to the LOW-to-HIGH clock transition, for predictable operation.

Schmitt trigger action at all inputs makes the circuit highly tolerant of slower input rise and fall times.

Features:

- Wide supply voltage range from 1.2V to 3.6V
- 5V tolerant inputs for interfacing with 5V logic
- CMOS low power consumption
- Direct interface with TTL levels
- Specified from -40°C to +105°C
- Packaging information: DIP14/SOP14/TSSOP14

**Ordering Information:****Tube packing specifications:**

Part number	Packaging form	Marking code	Tube quantity	Boxed tube quantity	Boxed quantity	Notes
AiP74LVC74DA14.TB	DIP14	74LVC74	25 PCS/tube	40 tube/box	1000 PCS/box	Dimensions of plastic enclosure: 19.0mm×6.4mm Pin spacing: 2.54mm
AiP74LVC74SA14.TB	SOP14	74LVC74	50 PCS/tube	200 tube/box	10000 PCS/box	Dimensions of plastic enclosure: 8.7mm×3.9mm Pin spacing: 1.27mm
AiP74LVC74TA14.TB	TSSOP14	74LVC74	94 PCS/tube	200 tube/box	18800 PCS/box	Dimensions of plastic enclosure: 5.0mm×4.4mm Pin spacing: 0.65mm

Reel packing specifications:

Part number	Packaging form	Marking code	Reel quantity	Boxed reel quantity	Notes
AiP74LVC74SA14.TR	SOP14	74LVC74	4000 PCS/reel	8000 PCS/box	Dimensions of plastic enclosure: 8.7mm×3.9mm Pin spacing: 1.27mm
AiP74LVC74TA14.TR	TSSOP14	74LVC74	5000 PCS/reel	10000 PCS/box	Dimensions of plastic enclosure: 5.0mm×4.4mm Pin spacing: 0.65mm

Note: If the physical information is inconsistent with the ordering information, please refer to the actual product.



2、Block Diagram And Pin Description

2.1、Block Diagram

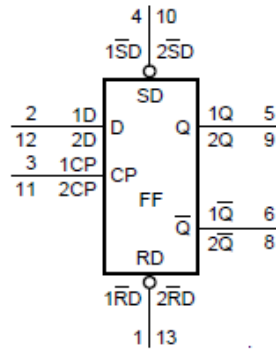

Figure 1. Logic symbol

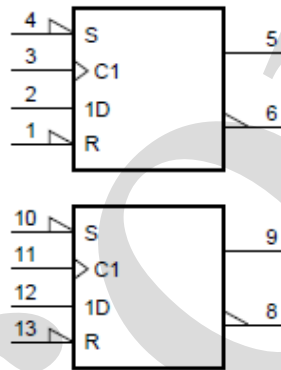

Figure 2. IEC logic symbol

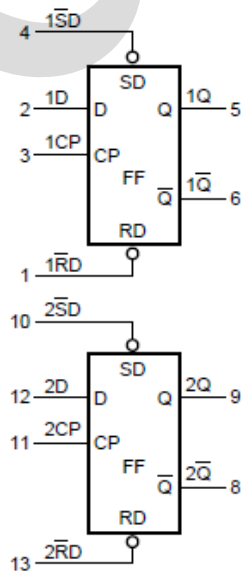

Figure 3. Functional diagram

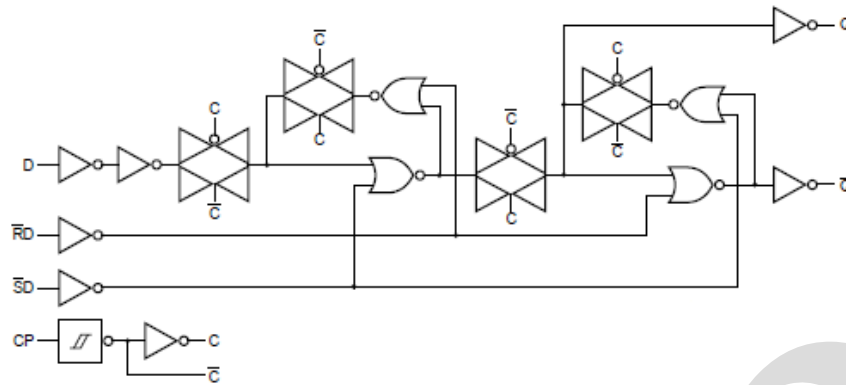
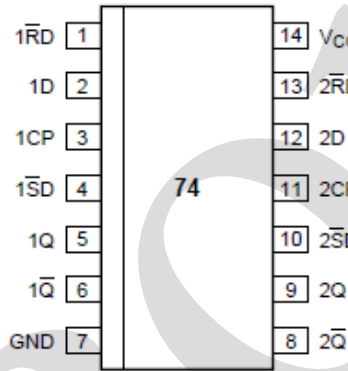

Figure 4. Logic diagram for one flip-flop

2.2. Pin Configurations



2.3. Pin Description

Pin No.	Pin Name	Description
1	1RD	asynchronous reset-direct input (active LOW)
2	1D	data input
3	1CP	clock input (LOW-to-HIGH, edge-triggered)
4	1SD	asynchronous set-direct input (active LOW)
5	1Q	true output
6	1Q	complement output
7	GND	ground (0V)
8	2Q	complement output
9	2Q	true output
10	2SD	asynchronous set-direct input (active LOW)
11	2CP	clock input (LOW-to-HIGH, edge-triggered)
12	2D	data input
13	2RD	asynchronous reset-direct input (active LOW)
14	V _{CC}	supply voltage



2.4、Function Table

Input				Output	
\bar{nSD}	\bar{nRD}	nCP	nD	nQ	\bar{nQ}
L	H	X	X	H	L
H	L	X	X	L	H
L	L	X	X	H	H

Note: H=HIGH voltage level; L=LOW voltage level; X=don't care.

Input				Output	
\bar{nSD}	\bar{nRD}	nCP	nD	nQ_{n+1}	\bar{nQ}_{n+1}
H	H	↑	L	L	H
H	H	↑	H	H	L

Note: H=HIGH voltage level; L=LOW voltage level;

↑= LOW-to-HIGH CP transition; X=don't care;

Q_{n+1} = state after the next LOW-to-HIGH CP transition.

3、Electrical Parameter

3.1、Absolute Maximum Ratings

(Voltages are referenced to GND(ground=0V), unless otherwise specified.)

Parameter	Symbol	Conditions	Min.	Max.	Unit
supply voltage	V_{CC}	-	-0.5	+6.5	V
input clamping current	I_{IK}	$V_I < 0V$	-50	-	mA
input voltage	V_I	-	-0.5	+6.5	V
output clamping current	I_{OK}	$V_O > V_{CC}$ or $V_O < 0V$	-	±50	mA
output voltage	V_O	-	-0.5	$V_{CC}+0.5$	V
output current	I_O	$V_O=0V$ to V_{CC}	-	±50	mA
supply current	I_{CC}	-	-	100	mA
ground current	I_{GND}	-	-100	-	mA
total power dissipation	P_{tot}	-	-	500	mW
storage temperature	T_{stg}	-	-65	+150	°C
Soldering temperature	T_L	10s	DIP	245	°C
			SOP	250	°C

Note:

[1] For DIP14 packages: above 70°C the value of P_{tot} derates linearly with 12mW/K.

[2] For SOP14 packages: above 70°C the value of P_{tot} derates linearly with 8mW/K.

[3] For (T)SSOP14 packages: above 60°C the value of P_{tot} derates linearly with 5.5mW/K.



3.2、Recommended Operating Conditions

Parameter	Symbol	Conditions	Min.	Typ.	Max.	Unit
supply voltage	V_{CC}	for maximum speed performance	1.65	-	3.6	V
		for low-voltage applications	1.2	-	3.6	
input voltage	V_I	-	0	-	5.5	V
output voltage	V_O	-	0	-	V_{CC}	V
ambient temperature	T_{amb}	-	-40	-	+105	°C
input transition rise and fall rate	$\Delta t/\Delta V$	$V_{CC}=1.65V$ to $2.7V$	-	-	20	ns/V
		$V_{CC}=2.7V$ to $3.6V$	-	-	10	ns/V

3.3、Electrical Characteristics

3.3.1、DC Characteristics 1

($T_{amb}=-40^{\circ}C$ to $+85^{\circ}C$, voltages are referenced to GND (ground=0V), unless otherwise specified.)

Parameter	Symbol	Conditions	Min.	Typ.	Max.	Unit	
HIGH-level input voltage	V_{IH}	$V_{CC}=1.2V$	1.08	-	-	V	
		$V_{CC}=1.65V$ to $1.95V$	$0.65 \times V_{CC}$	-	-	V	
		$V_{CC}=2.3V$ to $2.7V$	1.7	-	-	V	
		$V_{CC}=2.7V$ to $3.6V$	2.0	-	-	V	
LOW-level input voltage	V_{IL}	$V_{CC}=1.2V$	-	-	0.12	V	
		$V_{CC}=1.65V$ to $1.95V$	-	-	$0.35 \times V_{CC}$	V	
		$V_{CC}=2.3V$ to $2.7V$	-	-	0.7	V	
		$V_{CC}=2.7V$ to $3.6V$	-	-	0.8	V	
HIGH-level output voltage	V_{OH}	$V_I = V_{IH}$ or V_{IL}	$I_O=-100\mu A$; $V_{CC}=1.65V$ to $3.6V$	$V_{CC} - 0.2$	-	-	V
			$I_O=-4mA$; $V_{CC}=1.65V$	1.2	-	-	V
			$I_O=-8mA$; $V_{CC}=2.3V$	1.8	-	-	V
			$I_O=-12mA$; $V_{CC}=2.7V$	2.2	-	-	V
			$I_O=-18mA$; $V_{CC}=3.0V$	2.4	-	-	V
			$I_O=-24mA$; $V_{CC}=3.0V$	2.2	-	-	V
LOW-level output voltage	V_{OL}	$V_I = V_{IH}$ or V_{IL}	$I_O=100\mu A$; $V_{CC}=1.65V$ to $3.6V$	-	-	0.20	V
			$I_O=4mA$; $V_{CC}=1.65V$	-	-	0.45	V
			$I_O=8mA$; $V_{CC}=2.3V$	-	-	0.6	V
			$I_O=12mA$; $V_{CC}=2.7V$	-	-	0.4	V
			$I_O=24mA$; $V_{CC}=3.0V$	-	-	0.55	V
input leakage current	I_I	$V_I=5.5V$ or GND; $V_{CC}=3.6V$	-	± 0.1	± 5	μA	
supply current	I_{CC}	$V_I=V_{CC}$ or GND; $I_O=0A$; $V_{CC}=3.6V$	-	1.5	15	μA	
additional supply current	ΔI_{CC}	per input pin; $V_I=V_{CC}-0.6V$; $I_O=0A$; $V_{CC}=2.7V$ to $3.6V$	-	5	500	μA	
input capacitance	C_I	$V_{CC}=0V$ to $3.6V$; $V_I=$ GND to V_{CC}	-	4.0	-	pF	

Note: All typical values are measured at $V_{CC}=3.3V$ (unless stated otherwise) and $T_{amb}=25^{\circ}C$.



3.3.2、DC Characteristics 2

($T_{amb}=-40^{\circ}\text{C}$ to $+105^{\circ}\text{C}$, voltages are referenced to GND (ground=0V), unless otherwise specified.)

Parameter	Symbol	Conditions	Min.	Typ.	Max.	Unit	
HIGH-level input voltage	V_{IH}	$V_{CC}=1.2\text{V}$	1.08	-	-	V	
		$V_{CC}=1.65\text{V}$ to 1.95V	$0.65 \times V_{CC}$	-	-	V	
		$V_{CC}=2.3\text{V}$ to 2.7V	1.7	-	-	V	
		$V_{CC}=2.7\text{V}$ to 3.6V	2.0	-	-	V	
LOW-level input voltage	V_{IL}	$V_{CC}=1.2\text{V}$	-	-	0.12	V	
		$V_{CC}=1.65\text{V}$ to 1.95V	-	-	$0.35 \times V_{CC}$	V	
		$V_{CC}=2.3\text{V}$ to 2.7V	-	-	0.7	V	
		$V_{CC}=2.7\text{V}$ to 3.6V	-	-	0.8	V	
HIGH-level output voltage	V_{OH}	$V_I = V_{IH}$ or V_{IL}	$I_O=-100\mu\text{A}; V_{CC}=1.65\text{V}$ to 3.6V	$V_{CC} - 0.3$	-	-	V
			$I_O=-4\text{mA}; V_{CC}=1.65\text{V}$	1.05	-	-	V
			$I_O=-8\text{mA}; V_{CC}=2.3\text{V}$	1.65	-	-	V
			$I_O=-12\text{mA}; V_{CC}=2.7\text{V}$	2.05	-	-	V
			$I_O=-18\text{mA}; V_{CC}=3.0\text{V}$	2.25	-	-	V
			$I_O=-24\text{mA}; V_{CC}=3.0\text{V}$	2.0	-	-	V
LOW-level output voltage	V_{OL}	$V_I = V_{IH}$ or V_{IL}	$I_O=100\mu\text{A}; V_{CC}=1.65\text{V}$ to 3.6V	-	-	0.30	V
			$I_O=4\text{mA}; V_{CC}=1.65\text{V}$	-	-	0.65	V
			$I_O=8\text{mA}; V_{CC}=2.3\text{V}$	-	-	0.8	V
			$I_O=12\text{mA}; V_{CC}=2.7\text{V}$	-	-	0.6	V
			$I_O=24\text{mA}; V_{CC}=3.0\text{V}$	-	-	0.8	V
input leakage current	I_I	$V_I=5.5\text{V}$ or GND; $V_{CC}=3.6\text{V}$	-	-	± 20	μA	
supply current	I_{CC}	$V_I=V_{CC}$ or GND; $I_O=0\text{A}; V_{CC}=3.6\text{V}$	-	-	40	μA	
additional supply current	ΔI_{CC}	per input pin; $V_I=V_{CC}-0.6\text{V}; I_O=0\text{A}; V_{CC}=2.7\text{V}$ to 3.6V	-	-	5000	μA	

Note: All typical values are measured at $V_{CC}=3.3\text{V}$ (unless stated otherwise) and $T_{amb}=25^{\circ}\text{C}$.



3.3.3. AC Characteristics 1

($T_{amb} = -40^{\circ}\text{C}$ to $+85^{\circ}\text{C}$, voltages are referenced to GND (ground=0V), unless otherwise specified.)

Parameter	Symbol	Conditions	Min.	Typ.	Max.	Unit	
propagation delay	t_{pd}	nCP to nQ, nQ; see Figure 6	$V_{CC}=1.2\text{V}$	-	15	-	ns
			$V_{CC}=1.65\text{V to }1.95\text{V}$	1.0	5.0	10.3	ns
			$V_{CC}=2.3\text{V to }2.7\text{V}$	1.8	2.9	5.8	ns
			$V_{CC}=2.7\text{V}$	1.0	2.7	6.0	ns
		$V_{CC}=3.0\text{V to }3.6\text{V}$	1.0	2.6	5.2	ns	
		nSD to nQ, nQ; see Figure 7	$V_{CC}=1.2\text{V}$	-	15	-	ns
	$V_{CC}=1.65\text{V to }1.95\text{V}$		0.5	4.0	10.6	ns	
	$V_{CC}=2.3\text{V to }2.7\text{V}$		1.0	2.4	6.1	ns	
	$V_{CC}=2.7\text{V}$		1.0	2.9	6.4	ns	
	nRD to nQ, nQ; see Figure 7	$V_{CC}=3.0\text{V to }3.6\text{V}$	1.0	2.2	5.4	ns	
		$V_{CC}=1.2\text{V}$	-	15	-	ns	
		$V_{CC}=1.65\text{V to }1.95\text{V}$	0.5	4.1	10.7	ns	
$V_{CC}=2.3\text{V to }2.7\text{V}$		1.0	2.4	6.1	ns		
pulse width	t_w	clock HIGH or LOW; see Figure 6	$V_{CC}=1.65\text{V to }1.95\text{V}$	5.0	-	-	ns
			$V_{CC}=2.3\text{V to }2.7\text{V}$	4.0	-	-	ns
			$V_{CC}=2.7\text{V}$	3.3	-	-	ns
		$V_{CC}=3.0\text{V to }3.6\text{V}$	3.3	1.3	-	ns	
		Set or reset LOW; see Figure 7	$V_{CC}=1.65\text{V to }1.95\text{V}$	5.0	-	-	ns
			$V_{CC}=2.3\text{V to }2.7\text{V}$	4.0	-	-	ns
	$V_{CC}=2.7\text{V}$		3.3	-	-	ns	
	$V_{CC}=3.0\text{V to }3.6\text{V}$	3.3	1.7	-	ns		
recovery time	t_{rec}	set or reset; see Figure 7	$V_{CC}=1.65\text{V to }1.95\text{V}$	1.5	-	-	ns
			$V_{CC}=2.3\text{V to }2.7\text{V}$	1.5	-	-	ns
			$V_{CC}=2.7\text{V}$	1.5	-	-	ns
			$V_{CC}=3.0\text{V to }3.6\text{V}$	+1.0	-3.0	-	ns
set-up time	t_{su}	nD to nCP; see Figure 6	$V_{CC}=1.65\text{V to }1.95\text{V}$	3.0	-	-	ns
			$V_{CC}=2.3\text{V to }2.7\text{V}$	2.5	-	-	ns
			$V_{CC}=2.7\text{V}$	2.2	-	-	ns
			$V_{CC}=3.0\text{V to }3.6\text{V}$	2.0	0.8	-	ns
hold time	t_h	nD to nCP; see Figure 6	$V_{CC}=1.65\text{V to }1.95\text{V}$	2.0	-	-	ns
			$V_{CC}=2.3\text{V to }2.7\text{V}$	1.5	-	-	ns
			$V_{CC}=2.7\text{V}$	1.0	-	-	ns
			$V_{CC}=3.0\text{V to }3.6\text{V}$	+1.0	-0.2	-	ns
maximum frequency	f_{max}	nCP; see Figure 6	$V_{CC}=1.65\text{V to }1.95\text{V}$	100	-	-	MHz
			$V_{CC}=2.3\text{V to }2.7\text{V}$	125	-	-	MHz
			$V_{CC}=2.7\text{V}$	150	-	-	MHz
			$V_{CC}=3.0\text{V to }3.6\text{V}$	150	250	-	MHz
output skew time	$t_{sk(o)}$	$V_{CC}=3.0\text{V to }3.6\text{V}$	-	-	1.0	ns	



Power dissipation capacitance	C _{PD}	per flip-flop; V _I =GND to V _{CC}	V _{CC} =1.65V to 1.95V	-	12.4	-	pF
			V _{CC} =2.3V to 2.7V	-	16.0	-	pF
			V _{CC} =3.0V to 3.6V	-	19.1	-	pF

Note:

[1] Typical values are measured at T_{amb}=25°C and V_{CC}=1.2V, 1.8V, 2.5V, 2.7V and 3.3V respectively.

[2] t_{pd} is the same as t_{PLH} and t_{PHL}.

[3] Skew between any two outputs of the same package switching in the same direction. This parameter is guaranteed by design.

[4] C_{PD} is used to determine the dynamic power dissipation (P_D in uW).

$$P_D = (C_{PD} \times V_{CC}^2 \times f_i \times N) + \sum (C_L \times V_{CC}^2 \times f_o) \text{ where:}$$

f_i=input frequency in MHz;

f_o=output frequency in MHz;

C_L=output load capacitance in pF;

V_{CC}=supply voltage in V;

N=number of inputs switching;

$\sum (C_L \times V_{CC}^2 \times f_o)$ =sum of outputs.

3.3.4、 AC Characteristics 2

(T_{amb}=-40°C to +105°C, voltages are referenced to GND (ground=0V), unless otherwise specified.)

Parameter	Symbol	Conditions	Min.	Typ.	Max.	Unit	
propagation delay	t _{pd}	nCP to nQ, nQ; see Figure 6	V _{CC} =1.65V to 1.95V	1.0	-	11.9	ns
			V _{CC} =2.3V to 2.7V	1.8	-	6.7	ns
			V _{CC} =2.7V	1.0	-	7.5	ns
			V _{CC} =3.0V to 3.6V	1.0	-	6.5	ns
		nSD to nQ, nQ; see Figure 7	V _{CC} =1.65V to 1.95V	0.5	-	12.2	ns
			V _{CC} =2.3V to 2.7V	1.0	-	7.1	ns
			V _{CC} =2.7V	1.0	-	8.0	ns
			V _{CC} =3.0V to 3.6V	1.0	-	7.0	ns
		nRD to nQ, nQ; see Figure 7	V _{CC} =1.65V to 1.95V	0.5	-	12.4	ns
			V _{CC} =2.3V to 2.7V	1.0	-	7.1	ns
			V _{CC} =2.7V	1.0	-	8.0	ns
			V _{CC} =3.0V to 3.6V	1.0	-	7.0	ns
pulse width	t _w	clock HIGH or LOW; see Figure 6	V _{CC} =1.65V to 1.95V	5.0	-	-	ns
			V _{CC} =2.3V to 2.7V	4.0	-	-	ns
			V _{CC} =2.7V	4.5	-	-	ns
			V _{CC} =3.0V to 3.6V	4.5	-	-	ns
		Set or reset LOW; see Figure 7	V _{CC} =1.65V to 1.95V	5.0	-	-	ns
			V _{CC} =2.3V to 2.7V	4.0	-	-	ns
			V _{CC} =2.7V	4.5	-	-	ns
			V _{CC} =3.0V to 3.6V	4.5	-	-	ns
recovery time	t _{rec}	set or reset; see Figure 7	V _{CC} =1.65V to 1.95V	1.5	-	-	ns
			V _{CC} =2.3V to 2.7V	1.5	-	-	ns
			V _{CC} =2.7V	1.0	-	-	ns
			V _{CC} =3.0V to 3.6V	1.0	-	-	ns



set-up time	t_{su}	nD to nCP; see Figure 6	$V_{CC}=1.65V$ to $1.95V$	3.0	-	-	ns
			$V_{CC}=2.3V$ to $2.7V$	2.5	-	-	ns
			$V_{CC}=2.7V$	2.2	-	-	ns
			$V_{CC}=3.0V$ to $3.6V$	2.0	-	-	ns
hold time	t_h	nD to nCP; see Figure 6	$V_{CC}=1.65V$ to $1.95V$	2.0	-	-	ns
			$V_{CC}=2.3V$ to $2.7V$	1.5	-	-	ns
			$V_{CC}=2.7V$	1.0	-	-	ns
			$V_{CC}=3.0V$ to $3.6V$	1.0	-	-	ns
maximum frequency	f_{max}	nCP; see Figure 6	$V_{CC}=1.65V$ to $1.95V$	80	-	-	MHz
			$V_{CC}=2.3V$ to $2.7V$	100	-	-	MHz
			$V_{CC}=2.7V$	120	-	-	MHz
			$V_{CC}=3.0V$ to $3.6V$	120	-	-	MHz
output skew time	$t_{sk(o)}$	$V_{CC}=3.0V$ to $3.6V$		-	-	1.5	ns

Note:

[1] Typical values are measured at $T_{amb}=25^{\circ}C$ and $V_{CC}=1.2V, 1.8V, 2.5V, 2.7V$ and $3.3V$ respectively.

[2] t_{pd} is the same as t_{PLH} and t_{PHL} .

[3] Skew between any two outputs of the same package switching in the same direction. This parameter is guaranteed by design.

4、Testing Circuit

4.1、AC Testing Circuit

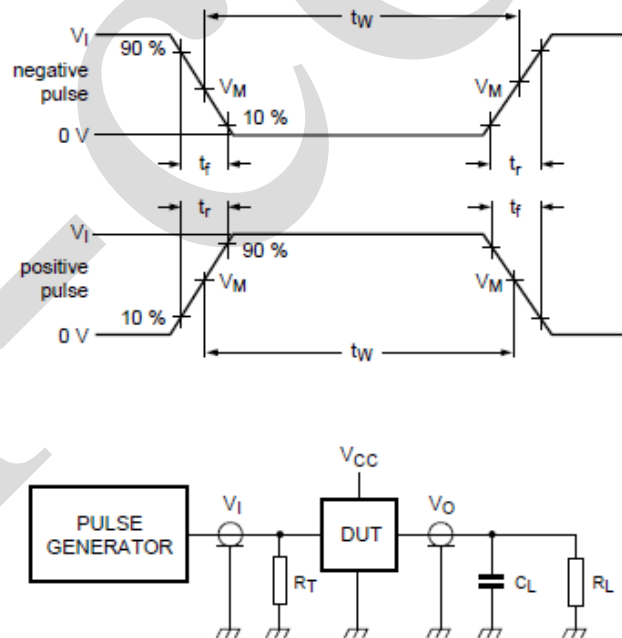

Figure 5. Load circuitry for switching times

Definitions for test circuit:

R_L =Load resistance.

C_L =Load capacitance including jig and probe capacitance.

R_T =Termination resistance should be equal to the output impedance Z_o of the pulse generator.



4.2、 AC Testing Waveforms

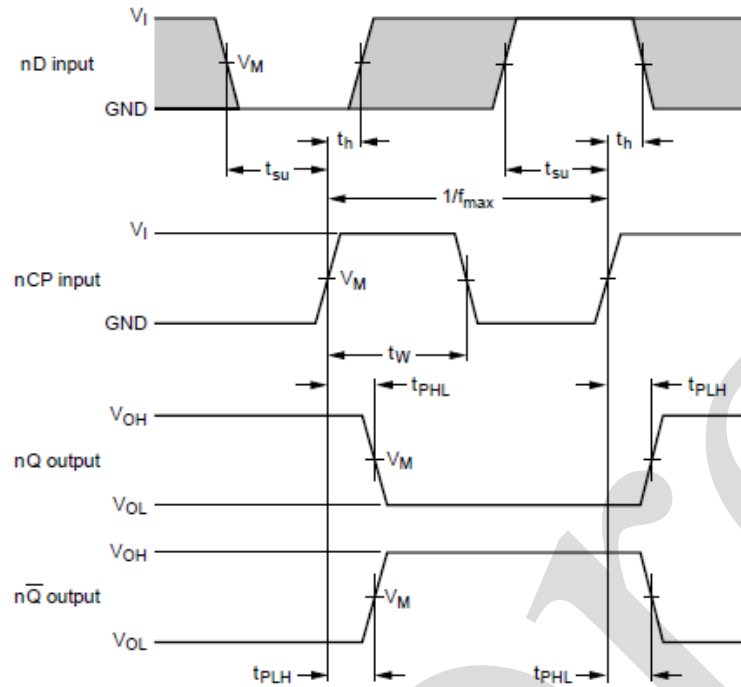

Figure 6. The clock input (nCP) to output (nQ, nQ) propagation delays, the clock pulse width, then D to nCP set-up, the nCP to nD hold times and the maximum frequency

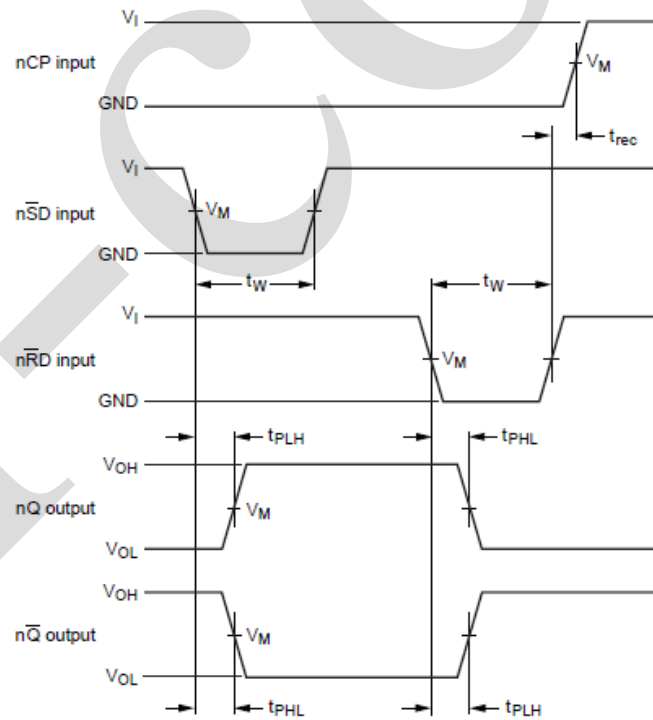

Figure 7. The set (nSD) and reset (nRD) input to output (nQ, nQ) propagation delays, the set and reset pulse widths and the nRD to nCP recovery time



4.3、Measurement Points

Supply voltage	Input		Output
V_{CC}	V_I	V_M	V_M
1.2V	V_{CC}	$0.5 \times V_{CC}$	$0.5 \times V_{CC}$
1.65V to 1.95V	V_{CC}	$0.5 \times V_{CC}$	$0.5 \times V_{CC}$
2.3V to 2.7V	V_{CC}	$0.5 \times V_{CC}$	$0.5 \times V_{CC}$
2.7V	2.7V	1.5V	1.5V
3.0V to 3.6V	2.7V	1.5V	1.5V

4.4、Test Data

Supply voltage	Input		Load		V_{EXT}		
V_{CC}	V_I	$t_r = t_f$	C_L	R_L	$t_{PLH},$ t_{PHL}	$t_{PZH},$ t_{PHZ}	$t_{PZL},$ t_{PLZ}
1.2V	V_{CC}	$\leq 2.0ns$	30pF	1k Ω	open	GND	$2 \times V_{CC}$
1.65V to 1.95V	V_{CC}	$\leq 2.0ns$	30pF	1k Ω	open	GND	$2 \times V_{CC}$
2.3V to 2.7V	V_{CC}	$\leq 2.0ns$	30pF	500 Ω	open	GND	$2 \times V_{CC}$
2.7V	2.7V	$\leq 2.5ns$	50pF	500 Ω	open	GND	$2 \times V_{CC}$
3.0V to 3.6V	2.7V	$\leq 2.5ns$	50pF	500 Ω	open	GND	$2 \times V_{CC}$



5、Package Information

5.1、DIP14

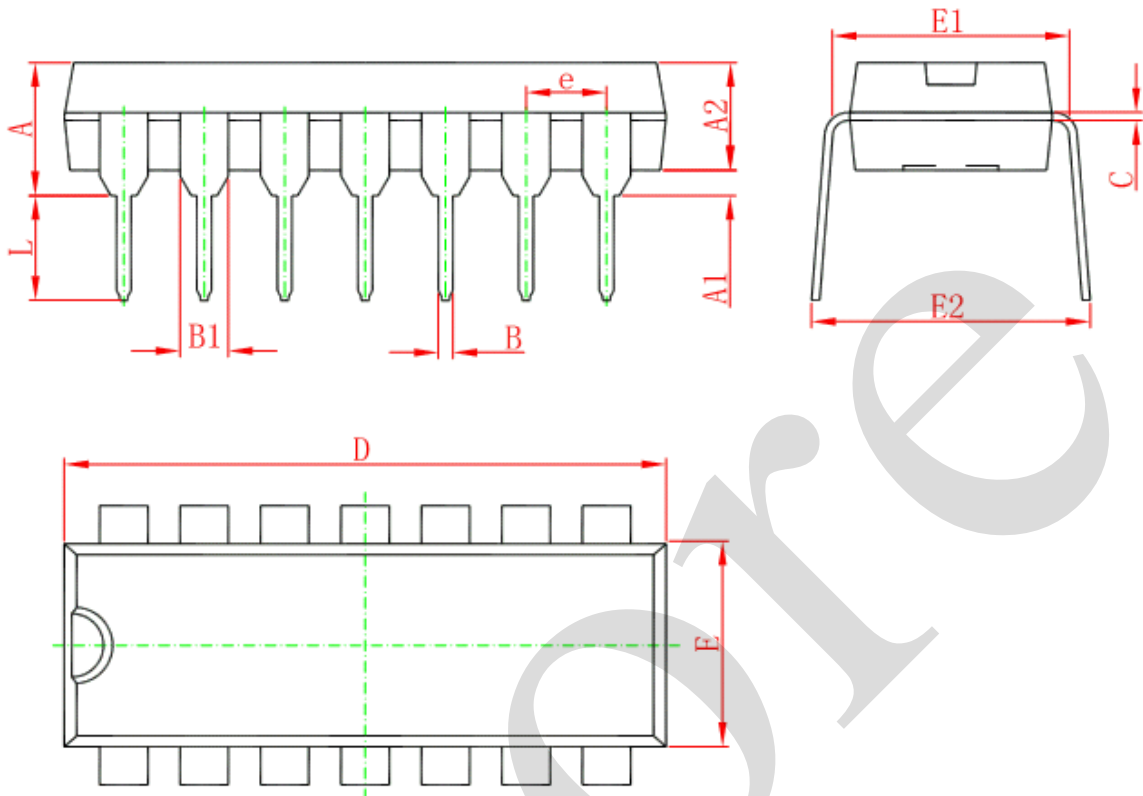

Symbol	Dimensions In Millimeters		Dimensions In Inches	
	Min	Max	Min	Max
A	3.710	4.310	0.146	0.170
A1	0.510		0.020	
A2	3.200	3.600	0.126	0.142
B	0.380	0.570	0.015	0.022
B1	1.524 (BSC)		0.060 (BSC)	
C	0.204	0.360	0.008	0.014
D	18.800	19.200	0.740	0.756
E	6.200	6.600	0.244	0.260
E1	7.320	7.920	0.288	0.312
e	2.540 (BSC)		0.100 (BSC)	
L	3.000	3.600	0.118	0.142
E2	8.400	9.000	0.331	0.354



5.2、SOP14

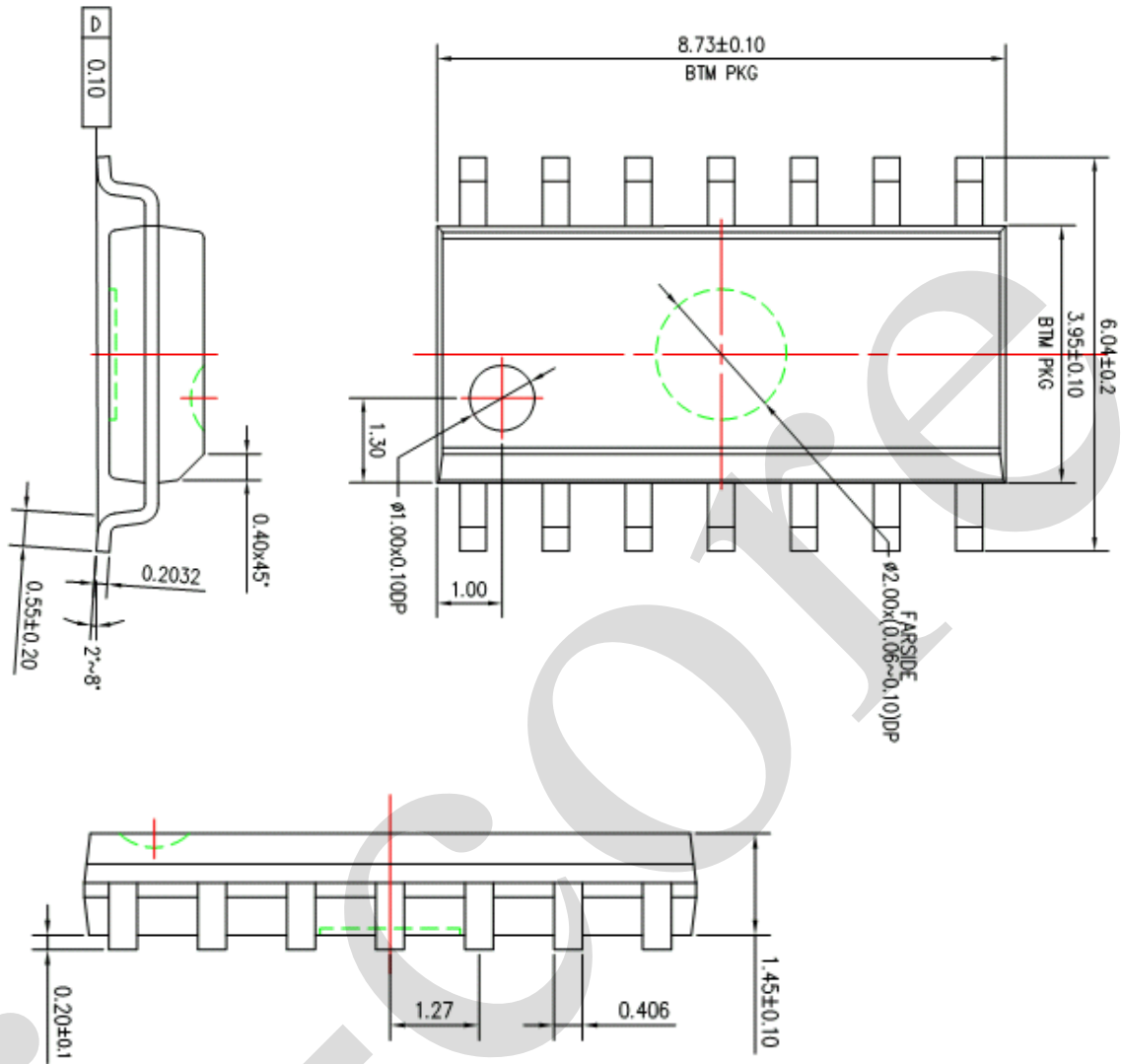



5.3、TSSOP14

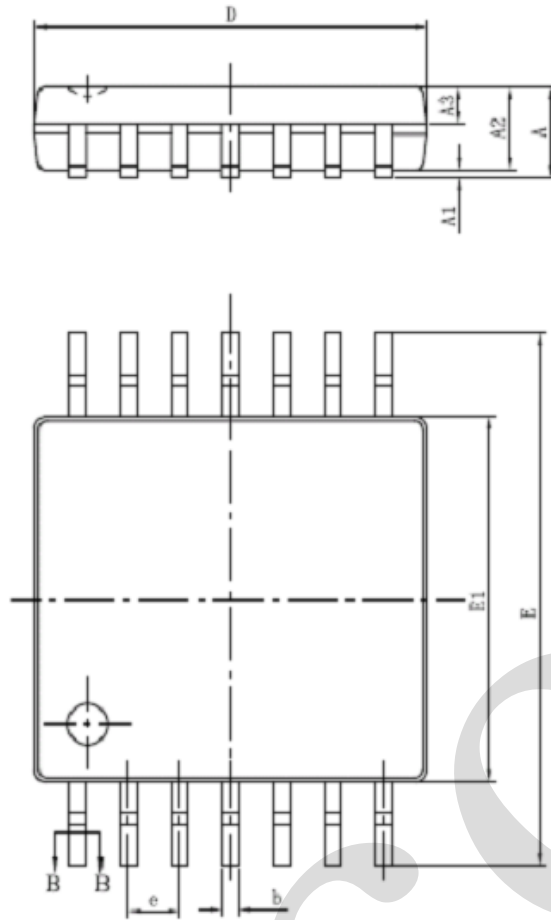

SYMBOL	MILLIMETER	
	MIN	MAX
A	—	1.20
A1	0.05	0.15
A2	0.90	1.05
A3	0.39	0.49
b	0.20	0.30
b1	0.19	0.25
c	0.13	0.19
c1	0.12	0.14
D	4.86	5.06
E1	4.30	4.50
E	6.20	6.60
e	0.65BSC	
L	0.45	0.75
L1	1.00BSC	
θ	0	8°

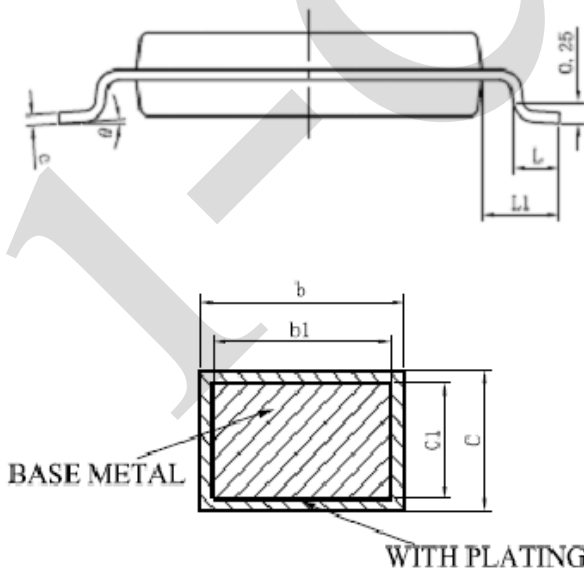

SECTION B-B



6、 Statements And Notes

6.1、 The name and content of Hazardous substances or Elements in the product

Part name	Hazardous substances or Elements									
	Lead and lead compounds	Mercury and mercury compounds	Cadmium and cadmium compounds	Hexavalent chromium compounds	Polybrominated biphenyls	Polybrominated biphenyl ethers	Dibutyl phthalate	Butylbenzyl phthalate	Di-2-ethylhexyl phthalate	Diisobutyl phthalate
Lead frame	○	○	○	○	○	○	○	○	○	○
Plastic resin	○	○	○	○	○	○	○	○	○	○
Chip	○	○	○	○	○	○	○	○	○	○
The lead	○	○	○	○	○	○	○	○	○	○
Plastic sheet installed	○	○	○	○	○	○	○	○	○	○
explanation	○: Indicates that the content of hazardous substances or elements in the detection limit of the following the SJ/T11363-2006 standard. ×: Indicates that the content of hazardous substances or elements exceeding the SJ/T11363-2006 Standard limit requirements.									

6.2、 Notion

Recommended carefully reading this information before the use of this product;

The information in this document are subject to change without notice;

This information is using to the reference only, the company is not responsible for any loss;

The company is not responsible for the any infringement of the third party patents or other rights of the responsibility.