

## Features

- Stable breakdown voltage
- High insulation resistance
- High current rating
- Low capacitance ( $\leq 1.5\text{pF}$ )
- Stable performance over life
- Large absorbing transient current capability
- Fast response time
- RoHS compliant
- Standard Size: 8.0mm\*8.0mm
- Meets MSL level 1, per J-STD-020
- Storage and operating temperature:  $-40^{\circ}\text{C} \sim +90^{\circ}\text{C}$

**GDT Graphical Symbol**

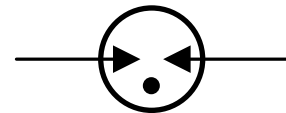

## Applications

- Repeaters, Modems
- Subscriber protection
- Telephone Interface, Line cards
- Data communication equipment
- Line test equipment
- Branch exchange
- Subscriber protection
- Alarm system
- Tuner
- Antenna protection

## Part Number Code and Marking

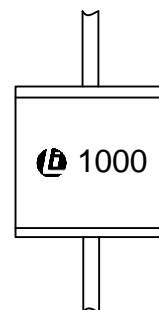
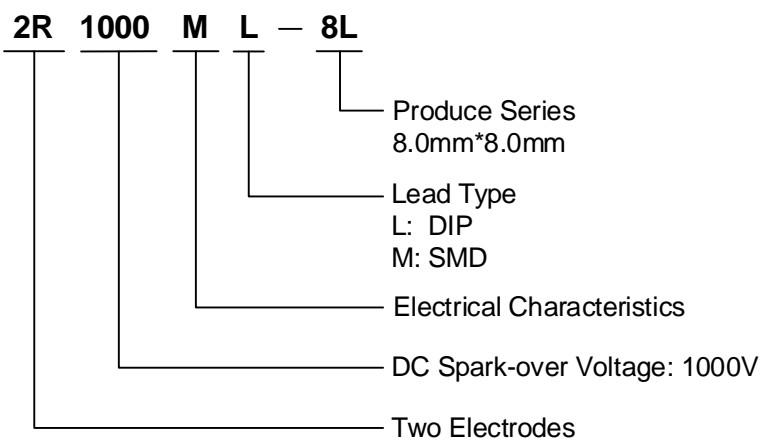

## Dimensions

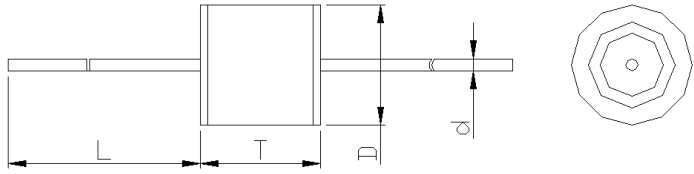
	Item	Dimensions(mm)
	D	8.0±0.3
	T	8.0+0.6/-0.1
	d	0.8±0.1
L	30.0 Max.	

## Electrical Characteristics (T<sub>A</sub>=25°C)

Part Number	Marking	DC Spark-over Voltage	Maximum Impulse Spark-over Voltage	Nominal Impulse Discharge Current	Alternating Discharge Current	Impulse Life	Minimum Insulation Resistance		Maximum Capacitance
		100V/s	1000V/μs	8/20μs, 10 times	50Hz, 1sec	10/1000μs, 100A	Test Voltage	GΩ	1MHz
2R1000ML-8L	1000	1000V±20%	1900V	10KA	10A	100 times	250VDC	1	1.5pF

## Test Methods and Results

Items	Test Method	Standard
DC Spark-over Voltage	measured with voltage ramp dv/dt=100V/s.	To meet the specified value
Maximum Impulse Spark-over Voltage	measured with voltage ramp dv/dt=1000V/μs.	
Impulse Discharge Current	applied between two electrodes, 5 positive and 5 negative surges, with 3 minutes interval time,	
Alternating Discharge Current	Rated RMS value of AC current at 50Hz, 1 sec. for 10 times with interval time 3 min.	
Insulation Resistance	measured between two electrodes.	
Capacitance	measured between two electrodes. Test frequency: 1MHz	

## Soldering Parameters

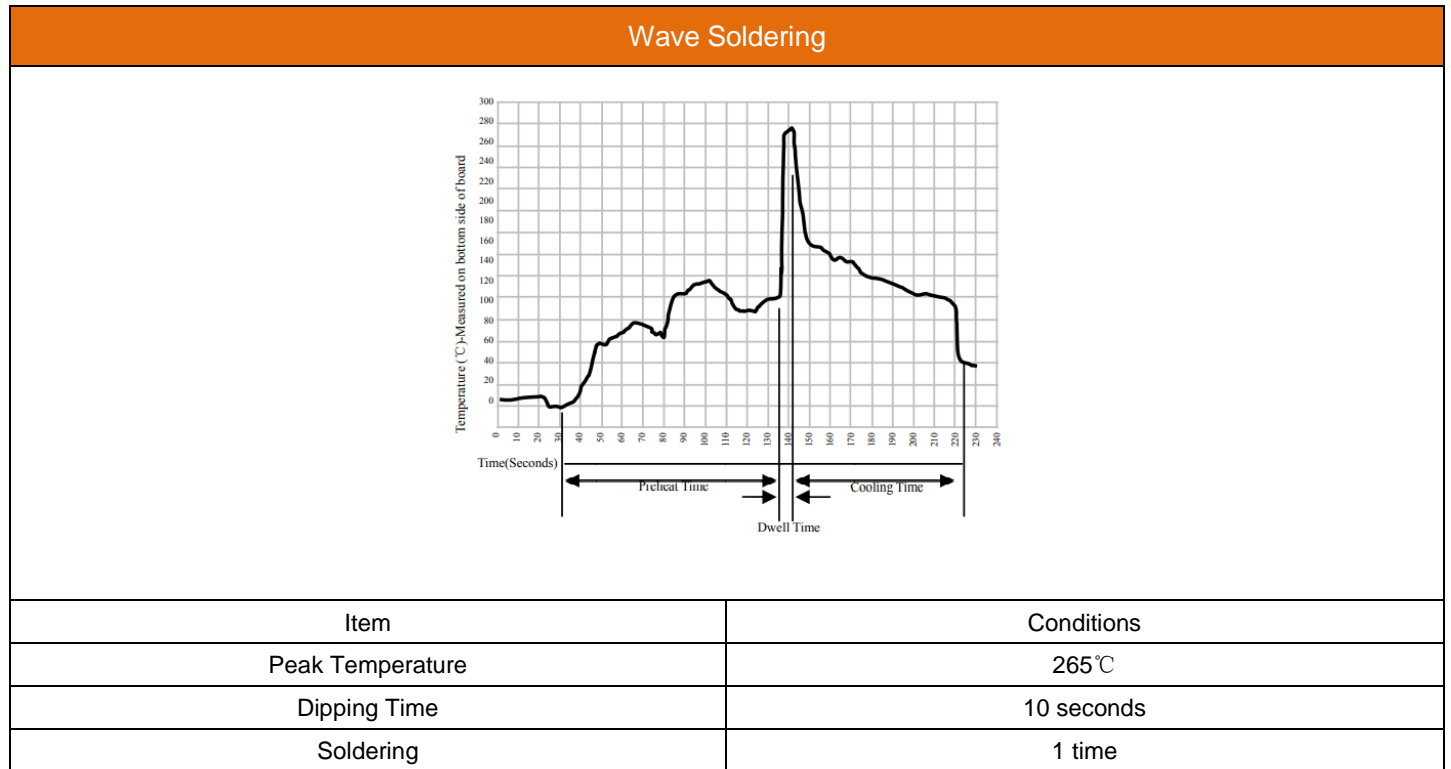

## Packaging Specification

Skin packing	Symbol	Dimension (mm)
	A	265.0±5.0
B	146.0±5.0	
H	9.5±1.0	
Quantity: 100pcs		
Inner box	A0	270.0±2.0
	B0	150.0±2.0
	H0	50.0±2.0
	Quantity: 500pcs	